

Section D
Pressure Relief Valves
and Relief Valve Manifolds

D

Limited 10 Year Warranty and Limitation Of Liability

LIMITED 10 YEAR WARRANTY

RegO warrants to the original purchasers the products and repair kits manufactured by it to be free from defects in materials and workmanship under normal use and service for a period of 10 years from the date of manufacture. If within thirty days after buyer's discovery of what buyer believes is a defect, buyer notifies in writing and ships the product to RegO at 100 RegO Drive, Elon, NC 27244, RegO, at its option, and within forty-five days of receipt, will repair, replace F.O.B. point of manufacture, or refund the purchase price of that part or product found by RegO to be defective. Failure of buyer to give such written notice and ship the product within thirty days shall be deemed an absolute and unconditional waiver of any and all claims of buyer arising out of such defect.

This warranty does not extend to any product or part that is not installed and used after installation in accordance with RegO's printed instructions, all applicable state and local regulations, and all applicable national standards, such as those promulgated by NFPA, DOT and ANSI. This warranty does not extend to any product or part that has been damaged by accident, misuse, abuse, failure to maintain, or neglect, nor does it extend to any product or part which has been modified, altered, disassembled, or repaired in the field. This warranty does not cover any cosmetic issues, such as scratches, dents, marring, fading of colors or discoloration.

Except as expressly set forth above, and subject to the limitation of liability below, RegO MAKES NO OTHER WARRANTY, EXPRESS OR IMPLIED, INCLUDING, BUT NOT LIMITED TO, THE IMPLIED WARRANTIES OF MERCHANTABILITY AND FITNESS FOR A PARTICULAR PURPOSE, with respect to its products and parts, whether used alone or in combination with others. RegO disclaims all warranties not stated herein.

LIMITATION OF LIABILITY

RegO's total liability for any and all losses and damages arising out of any cause whatsoever shall in no event exceed the purchase price of the products or parts in respect of which such cause arises, whether such cause be based on theories of contract, negligence, strict liability, tort or otherwise.

RegO shall not be liable for incidental, consequential or punitive damages or other losses. RegO shall not be liable for, and buyer assumes any liability for, all personal injury and property damage connected with the handling, transportation, possession, further manufacture, other use or resale of products, whether used alone or in combination with any other products or materials.

From time to time buyers might call to ask RegO for technical advice based upon limited facts disclosed to RegO. If RegO furnishes technical advice to buyer, whether or not at buyer's request, with respect to application, further manufacture or other use of the products and parts, RegO shall not be liable for such technical advice or any such advice provided to buyer by any third party and buyer assumes all risks of such advice and the results thereof.

NOTE: Some states do not allow the exclusion or limitation of incidental, consequential or punitive damages, so the above limitation or exclusion may not apply to you. The warranty gives you specific legal rights, and you may have other rights that vary from State to State. The portions of this limited warranty and limitation of liability shall be considered severable and all portions which are not disallowed by applicable law shall remain in full force and effect.

WARNING

All RegO products are mechanical devices that will eventually become inoperative due to wear, corrosion and aging of components made of material such as rubber, etc. The environment and conditions of use will determine the safe service life of these products. Periodic inspection and maintenance are essential to avoid serious injury and property damage.

Many RegO products are manufactured components which are incorporated by others on or in other products or systems used for storage, transport, transfer and otherwise for use of toxic, flammable and dangerous liquids and gases. Such substances must be handled by experienced and trained personnel only, using accepted governmental and industrial safety procedures.

NOTICE TO USERS OF PRODUCTS

The Limited Warranty stated above is a factory warranty to the first purchasers of RegO products. Since most users have purchased these products from RegO distributors, the user must within thirty (30) days after the user's discovery of what user believes is a defect, notify in writing and return the product to the distributor from whom he purchased the product/part. The distributor may or may not at the distributor's option choose to submit the product/parts to RegO, pursuant to this Limited Warranty. Failure by buyer to give such written notice within thirty (30) days shall be deemed an absolute and unconditional waiver of buyer's claim for such defects. Acceptance of any alleged defective product/parts by RegO's distributor for replacement or repairs under the terms of RegO's Limited Warranty in no way determines RegO's obligations under this Limited Warranty.

Because of a policy of continuous product improvement, RegO reserves the right to change designs, materials or specifications without notice.

Foreword

This catalog describes a complete line of equipment available from RegO® for use with Liquid Propane (LP)-Gas and anhydrous ammonia (NH₃). The following points are important to know for proper use of the catalog:

1. Illustrations and drawings of individual products are representative of “product groups” and all products within a product group are similar in construction.
2. Materials used for construction of products in this catalog are suitable for rated service pressure at temperatures of -40°F to +165°F, unless otherwise specified.
3. Products in this catalog are only intended for use in LP-Gas and/or anhydrous ammonia service as follows.
 - a. “A” or “AA” prefix — Products with this prefix are suitable for NH₃ service (i.e., contain no brass parts).
 - b. “AA” prefix on relief valves — These valves are NOT suitable for use with LP-Gas service. These are of partial aluminum materials and are listed by Underwriters Laboratories (UL) for NH₃ service only.
 - c. All other products including “A” prefix are suitable for use with LP-Gas & NH₃ service.
 - d. “SS” prefix—Hydrostatic relief valve with this prefix are suitable for NH₃ and LP-Gas service (i.e., they have stainless steel materials).
4. We manufacture valves and adapters designed to be used on LP-Gas and Anhydrous Ammonia systems, we do not design systems or consult in system design. For this type of information consult a professional Engineer.

Caution

Do not use any product contained in this catalog with any service commodity other than LP-Gas or NH₃. If you have a need for use of another application, contact RegO, 100 RegO Drive, Elon, NC 27244, (336) 449-7707 ecii@regoproducts.com before proceeding.

Proper application, installation and maintenance of products in this catalog are essential. Users of these products should obtain further information if there are any doubts or questions.

Warning

All RegO products are mechanical devices that will eventually become inoperative due to wear, corrosion and aging of components made of materials such as rubber. The environment and conditions of use will determine the safe service life of these products. Periodic inspection and maintenance are essential to avoid serious injury and property damage.

Many RegO products are manufactured for storage, transport, transfer and use of toxic flammable and dangerous liquids and gases. Such substances should be handled by experienced and trained personnel only, using accepted governmental and industrial safety procedures. Never vent LP-Gas near any possible source of ignition.

Notice

Installation, usage, and maintenance of all RegO products must be in compliance with all RegO instructions as well as requirements and provisions of NFPA #54, NFPA#58, DOT, ANSI, and all applicable federal, state, provincial and local standards, codes, regulations, and laws.

Inspection and maintenance on a periodic basis is essential. Installation and maintenance should be performed only by qualified personnel.

Be sure all instructions are read and understood before installation, operation and service.

Filters

RegO LP-Gas equipment is designed to operate in a system free from contamination. A variety of in-line filters are commercially available to the LP-Gas industry for installation in domestic systems.

The use of an in-line filter should be considered when other system components may be unclean and the system contaminated by rust, scale, dirt, debris or other foreign material.

Safety Warning – LP-Gas Pressure Relief Valves

Purpose

In its continuing quest for safety, RegO is publishing safety warning bulletins explaining the hazards associated with the use, misuse and aging of RegO Products. LP-Gas dealer managers and service personnel must realize that the failure to exercise the utmost care and attention in the installation, inspection and maintenance of these products can result in personal injury and property damage.

The National Fire Protection Association NFPA 58 Liquefied Petroleum Gas Code - 2017 Edition states in Section 4.4 Qualification of Personnel; "Persons whose duties fall within the scope of this code shall be provided with training that is consistent with the scope of their job activities and that includes proper handling and emergency response procedures... Refresher training shall be provided at least every 3 years, initial and subsequent training shall be documented". These "RegO Safety Warnings" may be useful in training new employees and reminding older employees of hazards that can occur. It is recommended that all employees complete the Propane Education Research Council's Certified Employee Training Program.

This Warning Bulletin should be provided to all purchasers of RegO and all personnel using or servicing these products. Additional copies are available from RegO and your Authorized RegO Distributor.

WARNING

What You Must Do:

- **Read This Entire Warning**
- **Install Properly**
- **Inspect Regularly**

Scope

This bulletin applies to pressure relief valves installed on stationary, portable and cargo containers and piping systems utilized with these containers. This bulletin is not intended to be an exhaustive treatment of this subject and does not cover all safety practices that should be followed in the installation and maintenance of LP-Gas systems. Each LP-Gas employee should be provided with a copy of NPGA Safety Pamphlet 306 "LP-Gas Regulator and Valve Inspection and Maintenance" as well as the NPGA "LP-Gas Training Guidebooks" relating to this subject.

Warnings should be as brief as possible. If there is a simple warning, it is:

Inspect pressure relief valves regularly. Replace unsafe or suspect valves immediately. Use common sense.

Inspect Regularly

A pressure relief valve discharges when some extraordinary circumstance causes an over pressure condition in the container. If a pressure relief valve is known to have discharged, the relief valve, as well as the entire system, should be immediately and thoroughly inspected to determine the reason for the discharge. In the case of discharge due to fire, the valve should be removed from service and replaced.

Relief valves should be inspected each time the container is filled but no less than once a year. If there is any doubt about the condition of the valve, it must be replaced.

Eye protection must be worn when performing inspection on relief valves under pressure. Never look directly into a relief valve under pressure or place any part of your body where the relief valve discharge could impact it. In some cases a flashlight and a small mirror are suggested to assist when making visual inspections.

To Properly Inspect A Pressure Relief Valve, Check For:

- 1. A rain cap.** Check protective cap located in valve or at end of pipeaway for a secure fit. Protective caps help protect the relief valve against possible malfunction caused by rain, sleet, snow, ice, sand, dirt, pebbles, insects, other debris and contamination. **REPLACE DAMAGED OR MISSING CAPS AT ONCE AND KEEP A CAP IN PLACE AT ALL TIMES.**
- 2. Open weep holes.** Dirt, ice, paint and other foreign particles can prevent proper drainage from the valve body. **IF THE WEEP HOLES CANNOT BE CLEARED, REPLACE THE VALVE.**
- 3. Deterioration and corrosion on relief valve spring.** Exposure to high concentrations of water, salt, industrial pollutants, chemicals and roadway contaminants could cause metal parts to fail. **IF THE COATING ON THE RELIEF VALVE SPRING IS CRACKED OR CHIPPED, REPLACE THE VALVE.**
- 4. Physical damage.** Ice accumulations and improper installation could cause mechanical damage. **IF THERE ARE ANY INDICATIONS OF DAMAGE, REPLACE THE VALVE.**
- 5. Tampering or readjustment.** Pressure relief valves are factory set to discharge at specified pressures. **IF THERE ARE ANY INDICATIONS OF TAMPERING OR READJUSTMENT, REPLACE THE VALVE.**
- 6. Seat leakage.** Check for leaks in the seating area using a noncorrosive leak detection solution. **REPLACE THE VALVE IF THERE IS ANY INDICATION OF LEAKAGE.** Never force a relief valve closed and continue to leave it in service. This could result in damage to the valve and possible rupture of the container or piping on which the valve is installed.
- 7. Corrosion and contamination. REPLACE THE VALVE IF THERE ARE ANY SIGNS OF CORROSION OR CONTAMINATION ON THE VALVE.**
- 8. Moisture, foreign particles or contaminants in the valve.** Foreign material such as paint, tar or ice in relief valve parts can impair the proper functioning of the valves. Grease placed in the valve body may harden over time or collect contaminants, thereby impairing the proper operation of the relief valve. **DO NOT PLACE GREASE IN THE VALVE BODY. REPLACE THE VALVE IF THERE ARE ANY INDICATIONS OF MOISTURE OR FOREIGN MATTER IN THE VALVE.**
- 9. Corrosion or leakage at container connection.** Check container to valve connection with a non-corrosive leak detection solution. **REPLACE THE VALVE IF THERE IS ANY INDICATION OF CORROSION OR LEAKAGE AT THE CONNECTION BETWEEN THE VALVE AND CONTAINER.**

CAUTION: Never plug the outlet of a pressure relief valve. Any device used to stop the flow of a properly operating pressure relief valve that is venting an overfilled or overpressurized container - raises serious safety concerns!

Replace Pressure Relief Valves In 10 Years Or Less

The safe useful life of pressure relief valves can vary greatly depending on the environment in which they live.

Relief valves are required to function under widely varying conditions. Corrosion, aging of the resilient seat disc and friction all proceed at different rates depending upon the nature of the specific environment and application. Gas impurities, product misuse and improper installations can shorten the safe life of a relief valve.

Predicting the safe useful life of a relief valve obviously is not an exact science. The conditions to which the valve is subjected will vary widely and will determine its useful life. In matters of this kind, only basic guidelines can be suggested. For example, the Compressed Gas Association Pamphlet S-1.1 Pressure Relief Device Standards — Cylinders, section 9.1.1 requires all cylinders used in industrial motor fuel service to have the cylinder's pressure relief valves replaced by new or unused relief valves within twelve years of the date of manufacture of cylinder and within each ten years thereafter. The LP-Gas dealer must observe and determine the safe useful life of relief valves in his territory. The valve manufacturer can only make recommendations for the continuing safety of the industry.

WARNING: Under normal conditions, the useful safe service life of a pressure relief valve is 10 years from the original date of manufacture. However, the safe useful life of the valve may be shortened and replacement required in less than 10 years depending on the environment in which the valve lives. Inspection and maintenance of pressure relief valves is very important. Failure to properly inspect and maintain pressure relief valves could result in personal injuries or property damage.

For Additional Information Read:

1. CGA Pamphlet S-1.1 Pressure Relief Standards - Cylinders, Section 9.1.1.
2. RegO Catalog L-500.
3. RegO Warning # 8545-500.
4. NPGA Safety Pamphlet 306 "LP-Gas Regulator and Valve Inspection and Maintenance" and "LP-Gas Training Guidebooks".
5. NFPA # 58, "Storage and Handling of Liquefied Petroleum Gases".
6. NFPA # 59, "LP-Gases at Utility Gas Plants".
7. ANSI K61.1 Safety Requirements for Storage and Handling of Anhydrous Ammonia.

RegO Pressure Relief Valves

Requirements for Pressure Relief Valves

Every container used for storing or hauling LP-Gas and anhydrous ammonia must be protected by a pressure relief valve. These valves must guard against the development of hazardous conditions which might be created by any of the following:

Hydrostatic pressures due to overfilling or the trapping of liquid between two points.

High pressures resulting from exposure of the container to excessive external heat.

High pressures due to the use of incorrect fuel.

High pressures due to improper purging of the container.

Consult NFPA Pamphlet #58 for LP-Gas and ANSI #K61.1 for anhydrous ammonia, and/or any applicable regulations governing the application and use of pressure relief valves.

Operation of Pressure Relief Valves

Pressure relief valves are set and sealed by the manufacturer to function at a specific "start-to-discharge" pressure in accordance with regulations. This set pressure, marked on the relief valve, depends on the design requirement of the container to be protected by the relief valve. If the container pressure reaches the start-to-discharge pressure, the relief valve will open a slight amount as the seat disc begins to move slightly away from the seat. If the pressure continues to rise despite the initial discharge through the relief valve, the seat disc will move to a full open position with a sudden "pop". This sharp popping sound is from which the term "pop-action" is derived.

Whether the relief valve opens a slight amount or pops wide open, it will start to close if the pressure in the container diminishes. After the pressure has decreased sufficiently, the relief valve spring will force the seat disc against the seat tightly enough to prevent any further escape of product. The pressure at which the valve closes tightly is referred to as the "re-seal" or "blow-down" pressure. Generally, the re-seal pressure will be lower than the start-to-discharge pressure. The re-seal pressure can be, and in most cases is, adversely affected by the presence of dirt, rust, scale or other foreign particles lodging between the seat and disc. They interfere with the proper mating of the seat and disc and the pressure in the container will usually have to decrease to a lower pressure before the spring force embeds foreign particles into the resilient seat disc material and seals leak-tight. The degree by which the presence of dirt decreases the re-seal pressure, is, of course, dependent on the size of the interfering particles.

Once particles have been trapped between the disc and seat, the start-to-discharge pressure is also affected. For example, the pressure relief valve will start-to-discharge at some pressure lower than its original start-to-discharge pressure. Again, the pressure at which the valve will start to discharge is dependent on the size of the foreign particles.

In the case of a pressure relief valve that has opened very slightly due to a pressure beyond its start-to-discharge setting, the chances of foreign material lodging between the seat and disc is negligible although the possibility is always present. If the relief valve continues to leak at pressures below its start-to-discharge setting it must be replaced.

Relief valves which have "popped" wide open must also be checked for foreign material lodged between the seat and disc, as well as for proper reseating of the seat and disc. Continued leakage at pressures below the start-to-discharge setting indicate the relief valve must be replaced.

The pressure at which a pressure relief valve will start to discharge should never be judged by the reading of the pressure gauge normally furnished on the container.

The reasons for this are two-fold:

If the relief valve is called upon to open, the resulting discharge produces an increased vaporization of the product in the container with the result that the liquid cools to a certain extent and the vapor pressure drops. A reading taken at this time would obviously not indicate what the pressure was when the relief valve opened.

The pressure gauges usually on most containers provide somewhat approximate readings and are not intended to provide an indication of pressure sufficiently accurate to judge the setting of the relief valve.

Repair and Testing

RegO Pressure Relief Valves are tested and listed by Underwriters Laboratories, Inc., in accordance with NFPA Pamphlet #58. Construction and performance of RegO Pressure Relief Valves are constantly checked at the factory by U.L. inspectors. Therefore, testing of RegO Pressure Relief Valves in the field is not necessary.

Any pressure relief valve which shows evidence of leakage, other improper operation or is suspect as to its performance must be replaced immediately using approved procedures.

Pipe-Away Adapters

Pipe-away adapters are available for most RegO Pressure Relief Valves, where it is required or desirable to pipe the discharge above or away from the container. Each adapter is designed to sever if excessive stress is applied to the vent piping – thus leaving the relief valve fully operative.

Weep hole deflectors are available on larger relief valves. These deflectors provide protection against flame impinging on adjacent containers which could occur from ignition of LP-Gas escaping through the relief valve drain hole when the valve is discharging.

Selection of RegO Pressure Relief Valves For ASME Containers

The rate of discharge required for a given container is determined by the calculation of the surface area of the container as shown in "Chart A" for LP-Gas and "Chart B" for anhydrous ammonia. See page D9.

Setting - The set pressure of a pressure relief valve depends upon the design pressure of the container. Refer to NFPA Pamphlet #58 for more information.

Selection of RegO Pressure Relief Valves for DOT Containers

To determine the proper relief valve required for a given DOT container, refer to the information shown with each pressure relief valve in the catalog. This information will give the maximum size (pounds water capacity) DOT container for which the relief valve has been approved.

Setting - The standard relief valve setting for use on DOT cylinders is 375 PSIG.

RegO Pressure Relief Valves

Ordering RegO Pressure Relief Valves

When ordering RegO Pressure Relief Valves, be sure you are certain that it will sufficiently protect the container as specified in the Foreword section, NFPA Pamphlet #58 and any other applicable standards or specifications.

All adapters, protective caps and deflectors must be ordered separately, unless specified otherwise.

Part Number Explanation

Products carrying an "A" or "AA" prefix contain no brass parts and are suitable for NH₃. Hydrostatic relief valves carrying an "SS" prefix are of stainless steel construction and are suitable for use with NH₃. The products are also suitable for use with LP-Gas service except relief valves carrying an "AA" prefix. These are of partial aluminum construction and are listed by U.L. for NH₃ service only.

Safety Information - Relief Valves Don't Last Forever

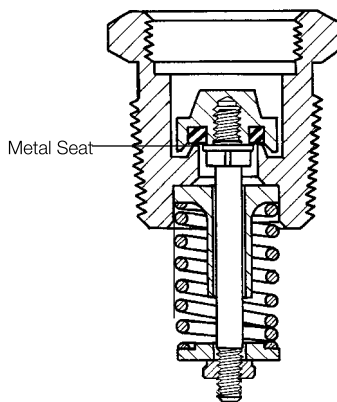

RegO Relief Valve for lift truck containers

The internal spring is protected from external contamination but the other external parts must be protected with a cap. Circular rubber seat disc ring seats on brass shoulder approximately 3/64" wide.

This article was prepared by the engineers of RegO products, after technical consultation with valve manufacturers and other industry sources. Its purpose is to alert and remind the LP-Gas industry of the importance of proper maintenance of pressure relief valves. It applies most particularly to separate relief valves with emphasis on lift truck and motor fuel containers where the hazards of contamination are greatest.

Since the beginning of our industry, manufacturers of equipment and distributors of LP-Gas have worked diligently to provide a safe environment for employees and consumers. The history of the industry testifies to the success of their efforts.

But the industry is now entering its sixth decade and equipment installed years ago is failing because of age. Every year, additional equipment will fail unless it is replaced. Pressure relief valves are no exception. The valve manufacturers and LP-Gas dealers are naturally concerned about this situation.

Causes of Relief Valve Failure

A relief valve is designed to have a safe useful life of many years, but that life will vary greatly depending on the environment in which it "lives." To attempt to estimate the safe useful life of a relief valve and the effect of environment on its performance, a brief discussion of the materials used and the nature of its performance should be helpful.

Relief valve bodies are generally made of brass or steel. Springs are made from various spring wires which are plated or painted, or made of stainless steel. Valve seat discs are made of synthetic rubber compounds which will remain serviceable in an atmosphere of LP-Gas. Relief valve stems, guides, etc. are generally made from brass or stainless steel.

Relief valves, over the years, may not function properly in several ways:

- They may leak at pressures below the set pressure.
- They may open and fail to properly reset.
- They may open at higher than the set pressure.

These failures to function properly are due primarily to four "environmental" conditions:

1. Corrosion of metal parts (particularly springs) which result in the component parts failing to perform.
2. Deterioration of the synthetic rubber seat disc material.
3. Clogging or "cementing" of the movable relief valve components so that their movement is restricted.
4. Debris on the valve seat after the relief valve opens, effectively preventing the valve from reseating.

Corrosion is caused by water, corrosive atmospheres of salt and industrial pollutants, chemicals, and roadway contaminants. High concentrations can attack the metal parts vigorously. No suitable metals are totally resistant to such corrosion.

Synthetic rubber and seat disc materials can also be attacked by impurities in the gas and corrosive atmospheres, particularly those with sulphur dioxide. There are no suitable rubber materials which resist all contaminants.

"Cementing" of relief valve parts has been caused by normal industrial atmospheres containing particles of dirt, iron oxide, metal chips, etc. combined with water, oil, or grease. Ice collecting in recessed valves could cause relief valves to fail to open. Paint and tar in relief valves also cause failure to function properly.

Safety Information - Relief Valves

Debris on valve seats which prevents reseating can occur whenever the valve collects material in the relief valve opening which is not blown out when the relief valve opens.

Inspection of Relief Valves

Unfortunately many of the above problems may not be easily observed because of the compact nature of some relief valve designs.

A casual visual inspection of a relief valve may not necessarily disclose a potential hazard. On the other hand, a visual inspection will often disclose leakage, corrosion, damage, plugging and contamination.

If additional light is required, a flashlight should be used.

If there is any doubt about the condition of the valve, or if there is a suspicion that the valve has not been protected by a cap for some time, it should be replaced before refilling the container.

Eye protection must be used when examining relief valves under pressure.

Smaller Relief Valves

The industry's requirement for a small full-flow safety relief valve challenged design engineers some years ago:

The valve must be leakproof before operating and must reseal leakproof each time after each operation. The only known satisfactory seat disc materials to accomplish this have been special synthetic rubber compounds.

- Valve discharge settings are relatively high and require high spring loads to keep the valve closed.
- Because of the small interior diameter of the valve, the round metal seating area is small.

All of these parameters may result in the development of a significant indentation in the rubber seat disc after some years. The seat disc may have a tendency to cling to the metal seat. This may result in the relief valve not opening at the set pressure as the seat disc ages.

Tests have been conducted on small LP-Gas relief valves of all the U.S. valve manufacturers. Valves over 10 years old were removed from service and tested to determine at what pressure the valves discharged. In many of the valves, the pressure required to open the valve exceeded the set pressure.

Because of the critical importance of proper functioning of relief valves, common sense and basic safety practice dictate that small relief valves should be replaced in about 10 years.

Some larger relief valves on bulk storage tanks can be replaced with rebuilt valves obtained from the manufacturers. Small relief valves cannot be rebuilt economically, thus, new valves are required. Most LP-Gas dealers find it impractical and costly to test relief valves and field repairing of relief valves is not sanctioned by the manufacturers, Underwriter's Laboratories, or ASME.

Use of Protective Caps

Many of the problems that cause inoperative relief valves could be prevented if proper protective caps were kept in place at all times.

Collection of debris would be prevented. Contamination caused by corrosive atmospheres would be reduced. Water collection in the valves would be eliminated. Relief valves protected with caps from the time of installation in the container would obviously have a much longer safe useful life, but they still should be replaced at some time because of the gradual deterioration of the rubber seat disc due to age alone.

NFPA 58 requires that protective caps must be kept in place as a protective cover on some relief valves. This is a mandatory requirement on several types of relief valves. The fact that use of caps may make inspection more time consuming should not be viewed as a reason for either not using the caps, or not making required periodic inspections.

In the event a relief valve has been used without the required cap, the relief valve should be thoroughly inspected and the required cap placed on the relief valve. If damage is noted to the relief valve, it should be replaced and the replacement valve should be capped. Relief valves with pipe-away adapters or deflectors used on lift truck containers have been found choked with debris. Inspection of relief valves with deflectors can only be accomplished by removing the deflector.

Similarly, larger relief valves with vent stacks have been found choked with debris and water. Valves have failed because springs rusted through. The weep hole was plugged. It was obvious that the relief valves had not been inspected in many years. These conditions must be alleviated by periodic inspections and replacement of relief valves as needed.

Summary Recommendations

Predicting the safe useful life of a relief valve is obviously not an exact science. The conditions to which the valve is subjected will vary widely and will largely control its life. In matters of this kind, only basic guidelines can be suggested. The LP-Gas dealer must observe and determine the safe useful life of relief valves in his territory. The valve manufacturers can only make recommendations for the continuing safety of the industry:

1. Make sure proper protective caps are in place at all times. Do not release a container for service or fill a container unless it has a protective cap in place.
2. Replace relief valves periodically, at least every 10 years. Every relief valve has the month and year of manufacture stamped on the valve. This is most particularly true of small separate relief valves.
3. Carefully inspect valves each time before the container is filled. Replace valves showing any signs of contamination, corrosion, damage, plugging, leakage, or any other problem. Eye protection must be used when examining relief valves under pressure.

Minimum Required Rate of Discharge for Pressure Relief Valves Used on ASME Containers

Chart A — Minimum Required Rate of Discharge for LP-Gas Pressure Relief Valves Used on ASME Containers

From NFPA Pamphlet #58, Appendix D (1986).

Minimum required rate of discharge in cubic feet per minute of air at 120% of the maximum permitted start-to-discharge pressure for pressure relief valves to be used on containers other than those constructed in accordance with Interstate Commerce Commission specification.

Surface Area Sq. Ft.	Flow Rate SCFM Air	Surface Area Sq. Ft.	Flow Rate SCFM Air	Surface Area Sq. Ft.	Flow Rate SCFM Air	Surface Area Sq. Ft.	Flow Rate SCFM Air	Surface Area Sq. Ft.	Flow Rate SCFM Air	Surface Area Sq. Ft.	Flow Rate SCFM Air	Surface Area Sq. Ft.	Flow Rate SCFM Air
20 or less	626	85	2050	150	3260	230	4630	360	6690	850	13540	1500	21570
25	751	90	2150	155	3350	240	4800	370	6840	900	14190	1550	22160
30	872	95	2240	160	3440	250	4960	380	7000	950	14830	1600	22740
35	990	100	2340	165	3530	260	5130	390	7150	1000	15470	1650	23320
40	1100	105	2440	170	3620	270	5290	400	7300	1050	16100	1700	23900
45	1220	110	2530	175	3700	280	5450	450	8040	1100	16720	1750	24470
50	1330	115	2630	180	3790	290	5610	500	8760	1150	17350	1800	25050
55	1430	120	2720	185	3880	300	5760	550	9470	1200	17960	1850	25620
60	1540	125	2810	190	3960	310	5920	600	10170	1250	18570	1900	26180
65	1640	130	2900	195	4050	320	6080	650	10860	1300	19180	1950	26750
70	1750	135	2990	200	4130	330	6230	700	11550	1350	19780	2000	27310
75	1850	140	3080	210	4300	340	6390	750	12220	1400	20380		
80	1950	145	3170	220	4470	350	6540	800	12880	1450	20980		

Surface area = Total outside surface area of container in square feet.

When the surface area is not stamped on the name plate or when the marking is not legible, the area can be calculated by using one of the following formulas:

1. Cylindrical container with hemispherical heads. Area (in sq. ft.) = overall length (ft.) x outside diameter (ft.) x 3.1416.
2. Cylindrical container with semi-ellipsoidal heads. Area (in sq. ft.) = overall length (ft.) + .3 outside diameter (ft.) x outside diameter (ft.) x 3.1416.
3. Spherical container. Area (in sq. ft.) = outside diameter (ft.) squared x 3.1416.

Flow Rate SCFM Air = Required flow capacity in cubic feet per minute of air at standard conditions, 60°F. and atmospheric pressure (14.7 psia).

The rate of discharge may be interpolated for intermediate values of surface area. For containers with total outside surface area greater than 2000 square feet, the required flow rate can be calculated using the formula, Flow Rate-SCFM Air = 53.632 A^{0.82} Where A = total outside surface area of the container in square feet.

Chart B — Minimum Required Rate of Discharge for Anhydrous Ammonia Pressure Relief Valves Used on ASME Containers

From ANSI K61.1-1981, Appendix A (1981).

Minimum required rate of discharge in cubic feet per minute of air at 120% of the maximum permitted start-to-discharge pressure for pressure relief valves to be used on containers other than those constructed in accordance with United States Department of Transportation cylinder specifications.

Surface Area Sq. Ft.	Flow Rate SCFM Air	Surface Area Sq. Ft.	Flow Rate SCFM Air	Surface Area Sq. Ft.	Flow Rate SCFM Air	Surface Area Sq. Ft.	Flow Rate SCFM Air	Surface Area Sq. Ft.	Flow Rate SCFM Air	Surface Area Sq. Ft.	Flow Rate SCFM Air	Surface Area Sq. Ft.	Flow Rate SCFM Air
20	258	95	925	170	1500	290	2320	600	4200	1350	8160	2100	11720
25	310	100	965	175	1530	300	2380	650	4480	1400	8410	2150	11950
30	360	105	1010	180	1570	310	2450	700	4760	1450	8650	2200	12180
35	408	110	1050	185	1600	320	2510	750	5040	1500	8900	2250	12400
40	455	115	1090	190	1640	330	2570	800	5300	1550	9140	2300	12630
45	501	120	1120	195	1670	340	2640	850	5590	1600	9380	2350	12850
50	547	125	1160	200	1710	350	2700	900	5850	1650	9620	2400	13080
55	591	130	1200	210	1780	360	2760	950	6120	1700	9860	2450	13300
60	635	135	1240	220	1850	370	2830	1000	6380	1750	10090	2500	13520
65	678	140	1280	230	1920	380	2890	1050	6640	1800	10330		
70	720	145	1310	240	1980	390	2950	1100	6900	1850	10560		
75	762	150	1350	250	2050	400	3010	1150	7160	1900	10800		
80	804	155	1390	260	2120	450	3320	1200	7410	1950	11030		
85	845	160	1420	270	2180	500	3620	1250	7660	2000	11260		
90	885	165	1460	280	2250	550	3910	1300	7910	2050	11490		

Surface area = Total outside surface area of container in square feet.

When the surface area is not stamped on the name plate or when the marking is not legible, the area can be calculated by using one of the following formulas:

1. Cylindrical container with hemispherical heads. Area (in sq. ft.) = overall length (ft.) x outside diameter (ft.) x 3.146.
2. Cylindrical container with other than hemispherical heads. Area (in sq. ft.) = overall length (ft.) + .3 outside diameter (ft.) x outside diameter (ft.) x 3.1416.
3. Spherical container. Area (in sq. ft.) = outside diameter (ft.) squared x 3.1416.

Flow Rate SCFM Air = Required flow capacity in cubic feet per minute of air at standard conditions, 60°F. and atmospheric pressure (14.7 psia).

The rate of discharge may be interpolated for intermediate values of surface area. For containers with total outside surface area greater than 2,500 square feet, the required flow rate can be calculated using the formula, Flow Rate-SCFM Air = 22.11 A^{0.82} where A = outside surface area of the container in square feet.

Conversion Factor

$$\begin{aligned} \text{ft}^2 \times 0.092903 &= \text{m}^2 \\ \text{SCFM} \times 0.028317 &= \text{m}^3/\text{min} \\ \text{ft} \times 0.3048 &= \text{m} \end{aligned}$$

“Pop-Action” Pressure Relief Valves

General Information

The “Pop-Action” design permits the RegO Pressure Relief Valve to open slightly to relieve moderately excessive pressure in the container. When pressure increases beyond a predetermined point, the valve is designed to “pop” open to its full discharge capacity, reducing excess pressure quickly. This is a distinct advantage over ordinary valves which open gradually over their entire range, allowing excessive pressure to develop before the relief valve is fully open. All RegO internal, semi-internal, and external relief valves incorporate this “Pop-Action” design.

Relief Valves in this catalog are only intended for use in LP-Gas or anhydrous ammonia service. Do not use any other service commodity. If you have an application other than conventional LP-Gas or anhydrous ammonia service, contact RegO before proceeding.

Fully Internal “Pop-Action” Pressure Relief Valves for Transports and Bobtail Delivery Vehicles A8434 and A8436 Series

Application

Designed specifically for use as a primary relief valve on ASME cargo tanks for transportation and bobtails with 2” and 3” F.NPT couplings.

Features

- Low profile design ensures maximum protection against shearing or distortion.
- All functioning parts are located below the level of the container connection to reduce the possibility of damage or tampering.
- Longer spring size designed to minimize stress cracking in service.
- Use of two different materials for stem and guide minimizes the possibility of stem seizure which may occur when similar materials are used.
- Internal octagonal wrenching broach ensures easy installation and removal.
- ASME rated for use with LP-Gas and anhydrous ammonia A8434 and A8436 Series
- ASME rated for use with LP-Gas and Propylene VA8436 Series

Materials

Body Stainless Steel
 Spring Stainless Steel
 Stem Stainless Steel
 Stem Bushing 17 - 4PH Stainless Steel
 Seat Disc (A8434 & A8436 series) Resilient Synthetic Rubber
 Seat Disc (VA8436 series) Viton

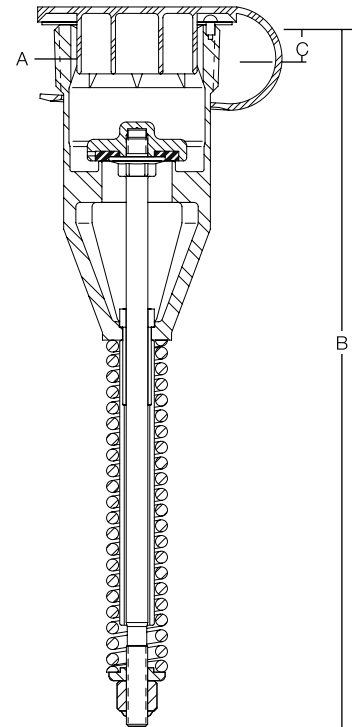

A8434-SERIES



Ordering Information

Part Number	Start To Discharge Setting PSIG	A Container Connection	B Overall Height (Approx.)	C Height Above Coupling (Approx.)	UL (At 120% of Set Pressure)	ASME (At 120% of Set Pressure)	LP-Gas	NH ₃	Propylene	Protective Cap (Included)
A8434G	250	2" M. NPT	9 1/16"	1/2"	3700	3456	Yes	Yes	No	A8434-11B
A8434N	265					3659				
A8436G	250	3" M. NPT	17 7/8"	3/4"	10210	9598				
A8436N	265					9839				
VA8436G	250					9596				
VA8436N	265					9839				
							No	Yes	A8436-11B	

* Per NFPA Pamphlet #58, Appendix D. Area shown is for UL or ASME flow rating—whichever is larger.

Fully Internal "Pop-Action" Pressure Relief Valves for Motor Fuel Containers 8543, 8544 and 8546 Series

Application

8543 Series relief valves are designed for use as a primary relief valve in larger ASME motor fuel containers such as on buses, RV's, trucks and construction equipment.

8544 Series relief valves are designed for use as a primary relief valve in smaller ASME and DOT motor fuel containers such as on tractors, lift trucks, cars and taxicabs.

Features

- Assure minimum product loss due to "pop-action" design.
- Recessed design minimizes possibility of damage and tampering.
- All are threaded to accept RegO Pipeaway Adapters that permit the addition of a discharge hose or piping.
- ASME rated for use with LP-Gas (except 8544K which meets DOT requirements).
- Specify RegO Relief Valves on all your original equipment motor fuel container purchases for reliable performance.

Materials

Body Brass
 Spring (8543)..... Stainless Steel
 Spring (8544)..... Coated Steel
 Seat Disc Resilient Rubber



8546-11 3/4"



7544-11A 1"



7543-10 1 1/4"



8544

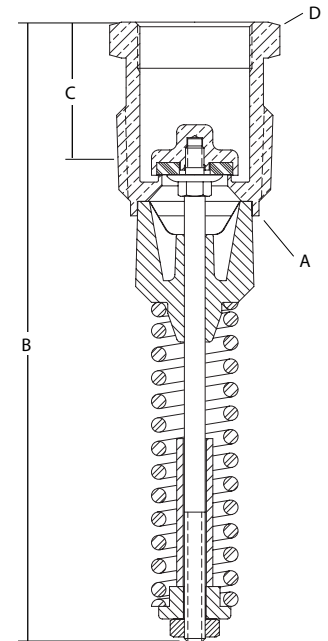

Ordering Information

Part Number	Container Type	Start To Discharge Setting PSIG	A Container Connection M. NPT	B Overall Height (Approx.)	C Height Above Coupling (Approx.)	D Hex Wrenching Section	Flow Capacity SCFM/Air****		Protective Cap (Included)	Accessories Pipeaway Adapter
							UL (At 120% of Set Pressure)	ASME (At 120% of Set Pressure)		
8546G	ASME	250	3/4"	4 1/2"	15/16"	1 1/16"	723	651	11565-26	8546-11
8544G			1"	5 7/16"	7/8"	5/16"	1020	936	7544-41G	7544-11A*
8543G			1 1/4"			1 1/16"	1465	1400	7543-40C	7543-10**
8546T		312	3/4"	4 1/2"	15/16"	1 1/16"	880	792	11565-26	8546-11
8544T			1"	5 7/16"	7/8"	5/16"	1282	1158	7544-41	7544-11A
8543T			1 1/4"			1 1/16"	1990	1731	7543-40C	7543-10**
8544A375T	DOT	375	1"			1 5/16"	NA	1384	7544-41G	7544-11A
8544K							1545***	NA	7544-41	7544-11A

* 1" M. NPT outlet connection.

** 1 1/4" M. NPT outlet connection.

*** Rating also applies to DOT requirements.

**** Flow rates shown are for bare relief valves. Adapters and pipeaway will reduce flow as discussed in the Foreword section.

Fully Internal "Pop-Action" Pressure Relief Valve for DOT Fork Lift Cylinders 8545AK

Application

Designed specifically for use as a primary relief valve on forklift cylinders, the 8545AK reduces the possibility of improper functioning of the relief mechanism due to foreign material build up. All guides, springs, stem and adjusting components are located inside the cylinder - removed from the direct exposure of foreign materials and debris from the atmosphere.

NFPA Pamphlet #58 requires that:

"All containers used in industrial truck (including forklift truck cylinders) service shall have the container pressure relief valve replaced by a new or unused valve within 12 years of the date of manufacture of the container and each 10 years thereafter."

Features

- Positive stop in the upper body protects against improper insertion of a pipeaway adapter that might interfere with proper operation of the relief valve.
- Internal stem guide eliminates the need for a close fit between the body and poppet, which lessens the chance of clogging due to foreign material.
- Single piece cold-headed stem provides more accurate positioning of working parts for more consistent operation and precise adjustment.
- Two different deflector adapters and a protective cap are available as accessories to provide complete protection.
- "Pop-action" design keeps product loss at a minimum.
- Request RegO Relief Valves on all your original equipment forklift cylinders for reliable performance.

Materials

Body	Brass
Stem	Stainless Steel
Spring	Stainless Steel
Poppet	Brass
Guide	Brass
Seat Disc	Resilient Rubber



7545-12 90° Adapter



7545-14 45° Adapter



8545AK

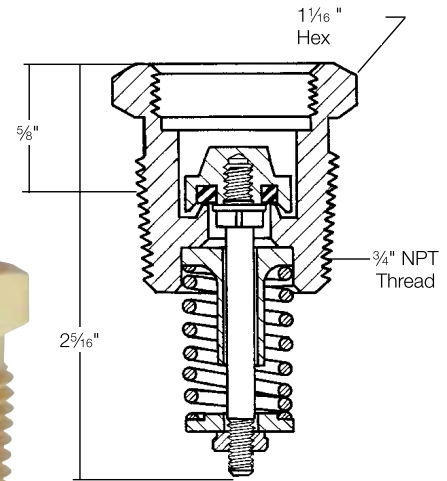

Ordering Information

Part Number	Container Type	Start To Discharge Setting PSIG	Container Connection M. NPT	Flow Capacity SCFM/Air** (RegO Rated at 480 PSIG)	Accessories (Order Separately)		
					Protective Cap	Deflectors***	
				45° Elbow		90° Elbow	
8545AK	Dot	375	3/4"	400*	11557-19	7545-14	7545-12

* Classified by U.L. in accordance with Compressed Gas Association Pamphlet S-1.1 Pressure Device Standards for Cylinders. Meets requirements for use on DOT containers with 262 pounds or less weight of water or 109 pounds or less of LP-Gas.

** Flow rates are shown for bare relief valves. Adapters and pipeaways will reduce flow as discussed in the Foreword section.

*** Order protective cap #8545-41 or 7545-40.

Semi-Internal "Pop-Action" Pressure Relief Valves for ASME Portable Containers 7583, 8684 and 8685 Series

Application

Designed for use as a primary relief valve on ASME containers such as 250, 500 and 1,000 gallon tanks. Underwriters' Laboratories lists containers systems on which these types of valves are mounted outside the hood without additional protection, if mounted near the hood and fitted with a protective cap.

Features

- Constructed of non-corrosive materials.
- "Pop-action" design keeps product loss at a minimum.
- ASME rated for use with LP-Gas.
- Request RegO Relief Valves on all your original equipment ASME containers for reliable performance.

Materials

Body Brass
 Spring Steel
 Stem Stainless Steel
 Seat Disc Resilient Rubber

Ordering Information

Part Number	Start To Discharge Setting PSIG	A Container Connection M. NPT	B Overall Height (Approx.)	C Height Above Coupling (Approx.)	D Wrench Hex Section	Flow Capacity SCFM/Air		Protective Cap (Included)
						UL (At 120% of Set Pressure)	ASME (At 120% of Set Pressure)	
7583G	250	¾"	8 ⅜"	1 ⅙"	1 ¼"	1980	1806	7583-40X
8684G		1"	9 ⅝"	1 ⅙"	1 ⅙"	2620	2565	8684-40
8685G		1 ¼"	11 ⅞"	1 ⅙"	2 ⅜"	4385	4035	7585-40X



7583G

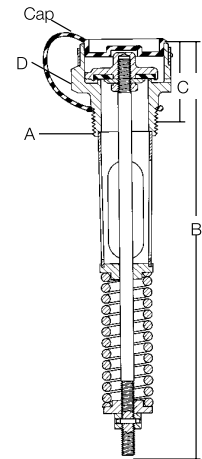

Application

Designed especially for use as a primary relief valve on large stationary storage containers, these low profile relief valves are generally mounted in half couplings. However, they are designed so that the inlet ports clear the bottom of a full 2" coupling. This ensures that the relief valve should always be capable of maximum flow under emergency conditions.

Features

- High capacity, low turbulence design has a maximum guiding area providing for dependable shut-off after opening.
- Built-in spring stop limits the rise of the seat in full open position and prevents the spring from going "solid."
- External 3" NPT threaded body allows easy attachment of vent stacks. Optional pipeaway adapter has break-off groove to prevent damage to the relief valve should piping be stressed by damaging winds.
- "Pop-Action" design keeps product loss at a minimum.
- No guiding projections around the seat disc retainer to bind and hinder opening of valve if body is damaged.



7534

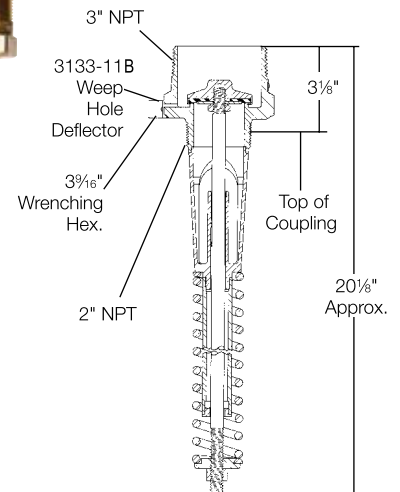

Materials

Body Brass
 Spring Steel
 Stem Stainless Steel
 Seat Disc Resilient Rubber

Ordering Information

Part Number	Start To Discharge Setting PSIG	Container Connection M. NPT	Flow Capacity SCFM/Air*		Accessories	
			UL (At 120% of Set Pressure)	ASME (At 120% of Set Pressure)	Protective Cap	Pipeaway Adapter
7534B	125	2"	6,025	-	7534-40X	7534-20**
7534G***	250		11,675	10,422		

* Flow rates shown are for bare relief valves. Adapters and pipeaways will reduce flow as discussed in the the Foreword section.

** 3" F. NPT outlet connection.

*** Other seat materials are available.

External "Pop-Action" Pressure Relief Valves for ASME Containers and Bulk Plant Installations AA3126, AA3130, 3131, 3132, 3133, 3135, AA3135, and A3149 Series

Application

Designed for use as a primary relief valve on ASME above ground and underground containers, bulk plant installations and skid tanks. The 3131 Series may also be used as a primary or secondary relief valve on DOT cylinders, or as a hydrostatic relief valve. All working components of these relief valves are outside the container connection, so the valves must be protected from physical damage.

Features

- "Pop-action" design keeps product loss at a minimum.
- Relief valve designed to automatically reset firmly after discharge.
- Resilient seat disc provides "bubble-tight" seal.
- 3149 relief valves incorporate integral pipeway adapter with break off groove that protects the valve from piping stress damage.
- Optional pipeway adapters have grooves that will break off to protect the relief valve from damage should excess stress be applied to the piping.
- 3149 relief valves include weep hole deflectors, installed to guard against flame impingement on adjacent containers.
- Most are ASME rated for use with LP-Gas and anhydrous ammonia.



3135-10



A3149

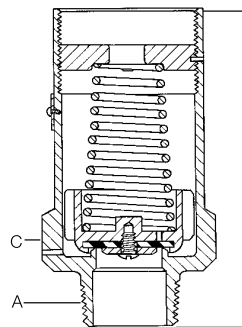

AA3135



3132-10

W3132G

D

Materials

Description	3131, 3132, 3133, 3135	AA3126 AA3130	AA3135	A3149
Body	Brass	Aluminum Rod*		Upper Cold Rolled Steel Lower Ductile Iron
Liner		None		Stainless Steel
Spring Guide	Brass	Aluminum		Stainless Steel
Spring	Corrosion Resistant Steel	Stainless Steel		Stainless Steel or Coated Steel
Seat Disc	Resilient Synthetic Rubber			



Ordering Information

Part Number	Start To Discharge Setting PSIG	A Container Connection M. NPT	B Overall Height (Approx.)	C Wrench Hex Section	Flow Capacity SCFM/Air (a)		Accessories			
					UL (At 120% of Set Pressure)	ASME (At 120% of Set Pressure)	Protective Cap	Pipeway Adapter		Weep Hole Deflector
								Part Number	Outlet Size	
AA3126L030	30	1/2"	2 3/8"	7/8"	(b)	-	9103-54	AA3126-10	1/2" M. NPT	-
A3149L055	55	2 1/2"	10 1/2"	4 1/8"	2608(c)	-	3149-40	(h)		Included (j)
A3149L200	200				8770 (c)	-				
AA3126L250	250	1/2"	2 3/8"	7/8"	277 (c)	-	9103-54	AA3126-10	1/2" M. NPT	3133-11
3131G		3/4"	3 7/16"	1 1/4"	2060	1939	3131-41 (g)	-	-	
AA3130UA250		1"	6 1/2"	2 3/8"	2045	1838	11557-110	AA3131-10	1" F. NPT	
W3132G					3340	-	3132-54 (g)	3132-10	1 1/4" F. NPT	
3132G		1 1/4"	5 21/32"	2 11/16"	4130	-	3135-54 (g)	-	-	
T3132G					3790	-		3132-10	1 1/4" F. NPT	
MV3132G					3995	-		-	-	
3135G		5770	-	3135-10	-					
AA3135UA250		6430	6341	AA3135-40PR	AA3135-10	2" F. NPT				
3133G		1 1/2"	5 19/16"	3 1/8"	6080	-	3133-54 (g)	3133-10	-	
A3149MG	2 1/2"	10 1/2"	4 1/8"	10390	-	3149-40	(h)		Included (j)	
A3149G				9153	-					
AA3130UA265	265	3/4"	3 7/16"	1 1/4"	2125	1912	11557-110	AA3131-10	1" F. NPT	-
AA3135UA265		1 1/4"	6 13/32"	2 11/16"	6615	6703	AA3135-40PR	AA3135-10	2" F. NPT	3133-11
AA3126L312	312	1/2"	2 3/8"	7/8"	330 (c)	-	9103-54	AA3126-10	1/2" M. NPT	-

(a) Flow rates shown are for bare relief valves. Adapters and pipeways will reduce flow as discussed in the Foreword section.
 (b) Not UL or ASME rated. .059 square inch effective area.
 (c) Not UL or ASME rated. RegO rated at 120% of set pressure.

(g) Cap supplied with chain.
 (h) Outlet 3 1/2-8N (F) thread, will accept 3" M. NPT pipe thread.
 (j) Weep hole deflector is Part No. A3134-11B.

External “Pop-Action” Supplementary Pressure Relief Valves for Small ASME Containers and DOT Cylinders 3127 and 3129 Series

Application

Designed for use as a supplementary relief valve on small ASME above ground and underground containers. They may also be used as a primary or secondary relief device on DOT cylinders, or as hydrostatic relief valves.

All working components of these relief valves are outside the container connection, so the valves must be protected from physical damage.

Features

- “Pop-action” design keeps product loss at a minimum.
- Relief valve designed to automatically reseal firmly after discharge.
- Resilient seat disc provides a “bubble-tight” seal.

Materials

Body Brass
 Spring Stainless Steel
 Seat Disc Resilient Rubber



3129-10 Pipe Away Adapter



3127 Series

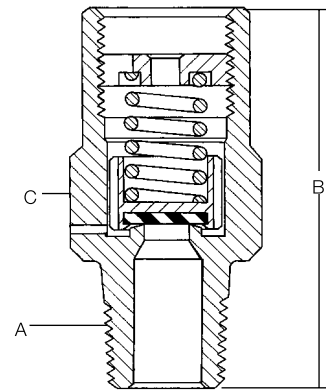
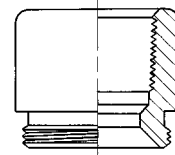

Ordering Information

Part Number	Container Type	Start To Discharge Setting PSIG	A Container Connection M. NPT	B Overall Height (Approx.)	C Wrench Hex Section	Flow Capacity SCFM/Air		Suitable for Tanks w/Surface Area Up To:*	Accessories		
						UL (At 120% of Set Pressure)	RegO Rated at 480 PSIG***		Protective Cap	Pipeaway Adapter	
										Part Number	Outlet Size
3127G	ASME	250	1/4"	1 3/32"	7/8"	295	-	-	9103-54	-	-
3129G			1/2"	2 19/32"	1 1/8"	465	-	-	3129-40P	3129-10	1/2" F. NPT
3127K	DOT	375	1/4"	1 3/32"	7/8"	-	450	100 lbs./Propane	9103-54	-	-
3129K			1/2"	2 19/32"	1 1/8"	-	780	200 lbs./Propane	3129-40P	3129-10	1/2" F. NPT

* Flow rates shown are for bare relief valves. Adapters and pipeaways will reduce flow as discussed in the Foreword section.

** Not UL or ASME rated. RegO rated at 480 PSIG.

*** Meets DOT requirements.

External Hydrostatic Relief Valves

3125, 3127, 3129, SS8001, SS8002, SS8021 and SS8022 Series

Application

Designed especially for the protection of piping and shut-off valves where there is a possibility of trapping liquid LP-Gas or anhydrous ammonia. They may be installed in pipelines and hoses located between shut-off valves or in the side boss of RegO shut-off valves.

Features

- Relief valve designed to automatically reseal firmly after discharge.
- Resilient seat disc provides a "bubble-tight" seal.
- Available in both brass and stainless steel.
- Available in configurations that permit direct attachment of vent piping when required.

Materials

Body (3125, 3127, 3129)..... Brass
 Body (SS8001, SS8002, SS8021, SS8022)..... Stainless Steel
 Spring Stainless Steel
 Seat Disc Resilient Rubber

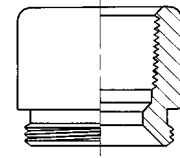

3129-10
Pipe Aw

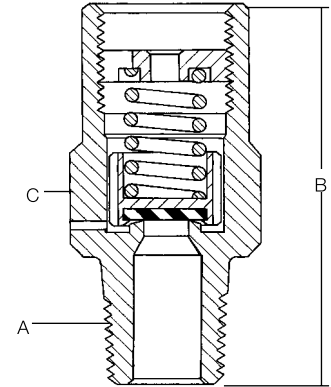

3125 Series (.161 Orifice)
3127 Series (.274 Orifice)
3129 Series (.386 Orifice)

Ordering Information

Part Number	Start To Discharge Setting PSIG	Valve Body Material	Container Connection M. NPT	Height (Approx.)	Wrench Hex Section	Accessories	
						Protective Cap	Pipeaway Adapter or Threads
SS8001G	250	Stainless Steel	1/4"	7/8"	11/16"	-	-
SS8002G			1/2"				7/8"
SS8021G			1/4"	1 3/8"	11/16"		1/4" NPSM Thrds
SS8022G			1/2"		7/8"		3/8" NPT Thrds
3127G	275	Brass	1/4"	1 31/32"	7/8"	9103-54	-
3129G			1/2"	2 19/32"	1 1/8"	3129-40P	3129-10*
3127H			1/4"	1 31/32"	7/8"	9103-54	-
3129H			1/2"	2 19/32"	1 1/8"	3129-40P	3129-10*
3127P	300	Brass	1/4"	1 31/32"	1 1/8"	9103-54	-
3129P			1/2"	2 19/32"	1 1/8"	3129-40P	3129-10*
SS8022P			1/2"	1 3/8"	7/8"	-	3/8" NPT Thrds
3127J	350	Brass	1/4"	1 31/32"	7/8"	9103-54	-
3129J			1/2"	2 19/32"	1 1/8"	3129-40P	3129-10*
SS8001J		Stainless Steel	1/4"	7/8"	11/16"	-	-
SS8002J			1/2"		7/8"		-
SS8021J	1/4"	1 3/8"	11/16"	1/4" NPSM Thrds			
SS8022J	1/2"		7/8"	3/8" NPT Thrds			
3127K	375	Brass	1/4"	1 31/32"	7/8"	9103-54	-
3129K			1/2"	2 19/32"	1 1/8"	3129-40P	3129-10*
3125L			1/4"	1 9/16"	5/8"	3125-40P	-
3127L			1/4"	1 31/32"	7/8"	9103-54	-
3129L	400	Brass	1/2"	2 19/32"	1 1/8"	3129-40P	3129-10*
SS8001L			1/4"	7/8"	11/16"	-	-
SS8002L			1/2"		7/8"		-
SS8021L			1/4"	1 3/8"	11/16"		1/4" NPSM Thrds
SS8022L	1/2"	7/8"	3/8" NPT Thrds				
3127U	450	Brass	1/4"	1 31/32"	7/8"	9103-54	-
3129U			1/2"	2 19/32"	1 1/8"	3129-40P	3129-10*
SS8001U			1/4"	7/8"	11/16"	-	-
SS8002U			1/2"		7/8"		-
SS8021U	1/4"	1"	11/16"	1/4" NPSM Thrds			
SS8022U	1/2"		7/8"	3/8" NPT Thrds			



SS8022G

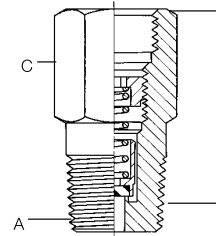

SS8021, SS8022 Series
(.156 Orifice)

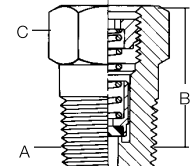

SS8001, SS8002 Series
(.156 Orifice)



* 1/2" F. NPT outlet connection.

DuoPort® Pressure Relief Valve Manifolds for Small Storage Containers 8542 Series

Application

Designed especially for use as a primary relief device on smaller stationary storage containers, with 2" NPT threaded couplings. These manifolds allow servicing or replacement of either of the two relief valves without evacuating the container or loss of service. The operating lever selectively closes off the entrance port to the relief valve being removed while the remaining valve provides protection for the container and its contents. The rating of each manifold is based on actual flow through the manifold and a single pressure relief valve, taking friction loss into account. It is not merely the rating of the relief valve alone.

Features

- Allows for relief valve removal and replacement on a periodic basis without shutting down and evacuating the container.
- Unique seat ring assemblies provide a smooth tubular section to preclude turbulence and ensure more efficient flow capacity.
- Operating lever is only locked in the mid-position or in a position to seal either relief valve. Placement of the clapper disc in an intermediate position could restrict flow through one of the relief valves, causing it to chatter and destroy the resilient seat disc.
- A rubber plug with chain is provided to protect manifold outlet threads where the relief valve has been removed.
- "Pop-action" design insures maximum protection with only minimal product loss at moderately excessive pressures.
- Resilient relief valve seat disc provides "bubble-tight" seal.
- Relief valves are ASME rated for use with LP-Gas and anhydrous ammonia.

Manifold Materials

Body Ductile Iron
Clapper Disc..... Stainless Steel
Bleeder Valve Stainless Steel
Seat Disc Teflon
Packing..... Polyethylene

Relief Valve Materials

Body Forged Aluminum*
Spring Guide..... Aluminum
Spring Coated Steel
Seat Disc Resilient Synthetic Rubber

*A special coating is applied to the inlet threads to minimize the possibility of electrolytic action.

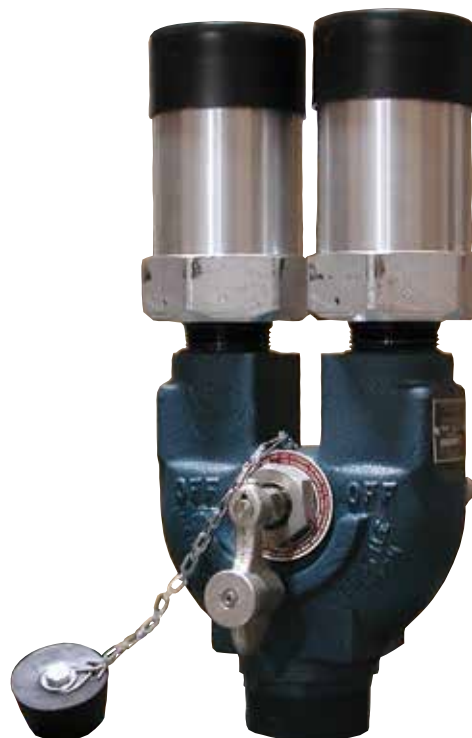

8542

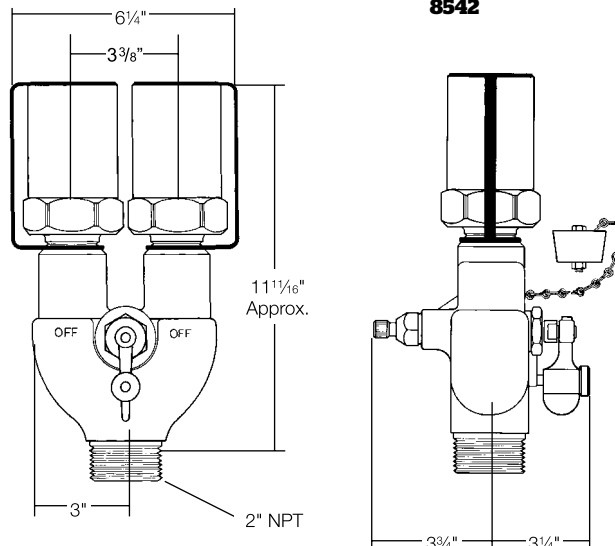

Ordering Information

Part Number	Start to Discharge Setting PSIG	Application		Container Connection M. NPT	Relief Valve Included				Flow Capacity SCFM/Air** (at 120% of set pressure)			
		LP-Gas	NH ₃		Quantity	Part Number	Inlet Connection M. NPT	Accessories Pipeaway Adaptors	UL Rating (at 120% of set Pressure)	ASME Rating (at 120% of set Pressure)		
8542G	250	Yes	No	2"	2	3135MG	1 1/4"	3135-10*	5250 (1)	NA		
8542AG									NA	5549 (1)		
AA8542UA250	265	No	Yes						AA3135MUA250	AA3135-10*	6430 (1)	6341 (1)
AA8542UA265									AA3135MUA265		6615 (1)	6703 (1)

* 2" F. NPT outlet connection.

** Flow rating based on number of relief valves indicated in parenthesis (). Flow rates shown are for bare relief valves. Adapters and pipeaways will reduce flow rates as discussed in the Foreword section.

Delta Port Relief Valve Manifolds

8530/AA8530 Series

Application

Designed especially for use as a primary relief device on large stationary pressurized storage containers, the base is supplied with a two-inch NPT threaded container connection. These manifolds incorporate an additional relief valve, not included in the flow rating, allowing for servicing or replacement of any one of the relief valves without evacuating the container. The hand-wheel on the manifold selectively closes off the entrance port to the relief valve being removed while the remaining relief valves provide protection for the container and its contents. All manifold flow ratings are based on flow through the relief valves after one has been removed for service or replacement.

Materials

Body Ductile Iron
 Resilient Parts Teflon
 Clapper Disc Stainless Steel
 Bleeder Valve Stainless Steel

Relief Valve Materials

Body (3135) Brass
 Spring Guide (3135) Brass
 Body (AA3135) Aluminum
 Spring Guide (AA3135) Aluminum
 Spring (3135 & AA3135) Stainless Steel
 Seat Disc (3135 & AA3135) Resilient Synthetic Rubber



8533AG

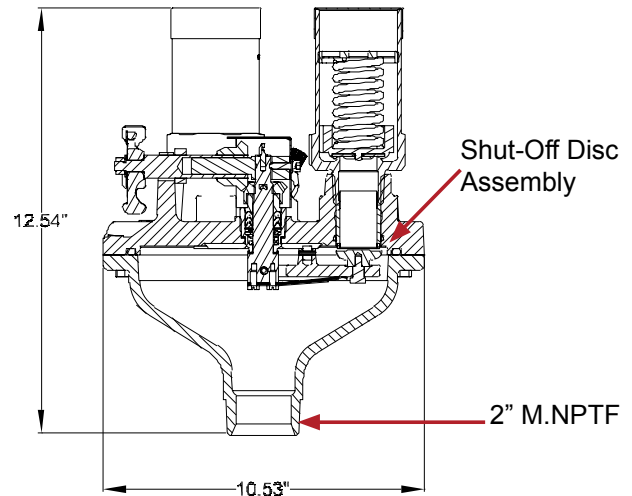
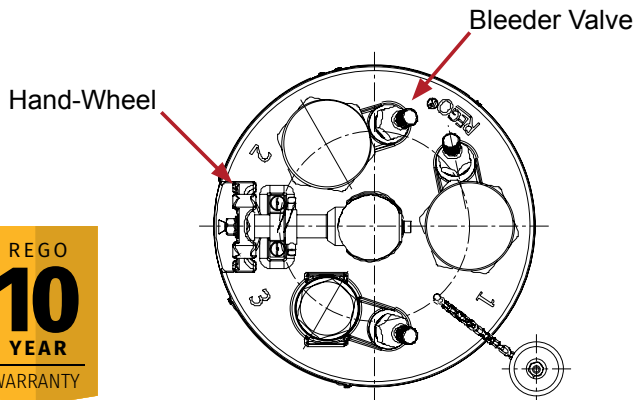

Ordering Information

Part Number	Start to Discharge Setting PSIG	Application		Container Connection M.NPTF	Qty.	Relief Valve		Accessories Pipe-away Adapter**	ASME Flow Rating SCFM (air) @ 120% of Set Pressure *
		LPG	NH ₃			Part Number	Inlet Connection M.NPT		
8532AG	250	Yes	No	2"	2	3135MG	1/4"	3135-10	5,549 (1)
8533AG					3				11,098 (2)
AA8532MA250		No	Yes		2	AA3135MA250		AA3135-10	6,341 (1)
AA8533MA250					3				12,682 (2)
AA8532MA265	265	No	Yes	2	AA3135MA265	AA3135-10	6,615 (1)		
AA8533MA265				3			13,230 (2)		

* Flow rating based on number of relief valves indicated in parentheses ().
 Flow rates shown are for bare relief valves. Adapters and pipe-aways will reduce flow rates as discussed in forwarding information in L-500 catalog. ** 2" F. NPT outlet connection

Multiport™ Pressure Relief Valve Manifold Assemblies for Large Storage Containers A8560, A8570 and AA8570 Series

Application

Designed especially for use as a primary relief device on large stationary pressurized storage containers with flanged openings. These manifolds incorporate an additional relief valve, not included in the flow rating, allowing for servicing or replacement of any one of the relief valves without evacuating the container. The handwheel on the manifold selectively closes off the entrance port to the relief valve being removed while the remaining relief valves provide protection for the container and its contents. All manifold flow ratings are based on flow through the relief valves after one has been removed for service or replacement.

Features

- Allows for relief valve removal and replacement on a periodic basis without shutting down and evacuating the container.
- "Pop-action" design of relief valves insures maximum protection with only minimal product loss at moderately excessive pressures.
- A rubber plug with chain is provided to protect manifold outlet threads where the relief valve has been removed.
- May be mounted directly to a welding neck flange or manhole cover plate. Requires no inlet piping.
- Relief valves designed to automatically reseal firmly after discharge.
- Resilient relief valve seat disc provides "bubble-tight" seal.
- Relief valves are ASME rated for use with LP-Gas and anhydrous ammonia.

Materials

Body Ductile Iron
 Resilient Parts Teflon
 Clapper Disc Stainless Steel
 Bleeder Valve Stainless Steel



A8560
A8570

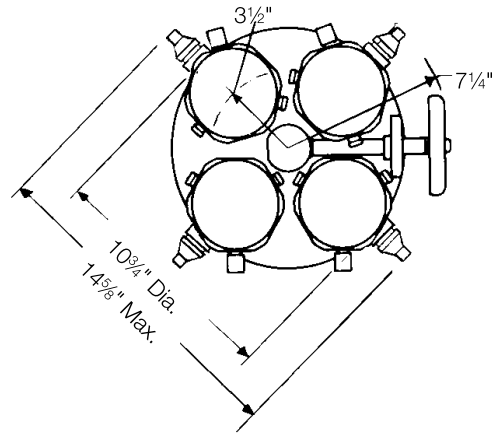

Pipe-Away Section
Will Accept 3" NPT Pipe

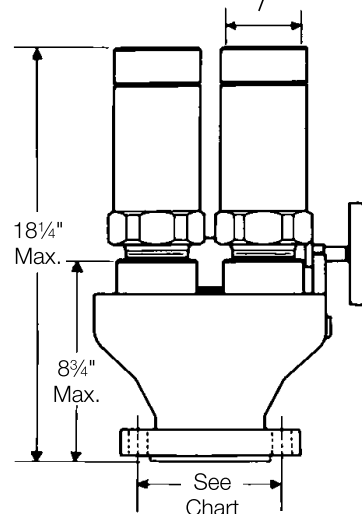

Bolt Stud and Nut Assemblies

Part Number	Consists of	For Use With:	For Connection To:	Number Required
7560-55	1-Bolt Stud and Nut	All RegO Multiports™	Modified 3" - 300# and 4"-ANSI 300#	8
7560-56			Welding Neck Flange Manhole Cover Plate	

Relief Valve Materials

Description	A8563, A8564, A8573, A8574
Body	Upper Cold Rolled Steel Lower Ductile Iron
Liner	Stainless Steel
Spring Guide	Stainless Steel
Spring	Coated Steel
Seat Disc	Resilient Synthetic Rubber

*A special coating is applied to the inlet threads to minimize possibility of electrolytic action.

Typical RegO Multiport™ Pressure Relief Valve Manifold

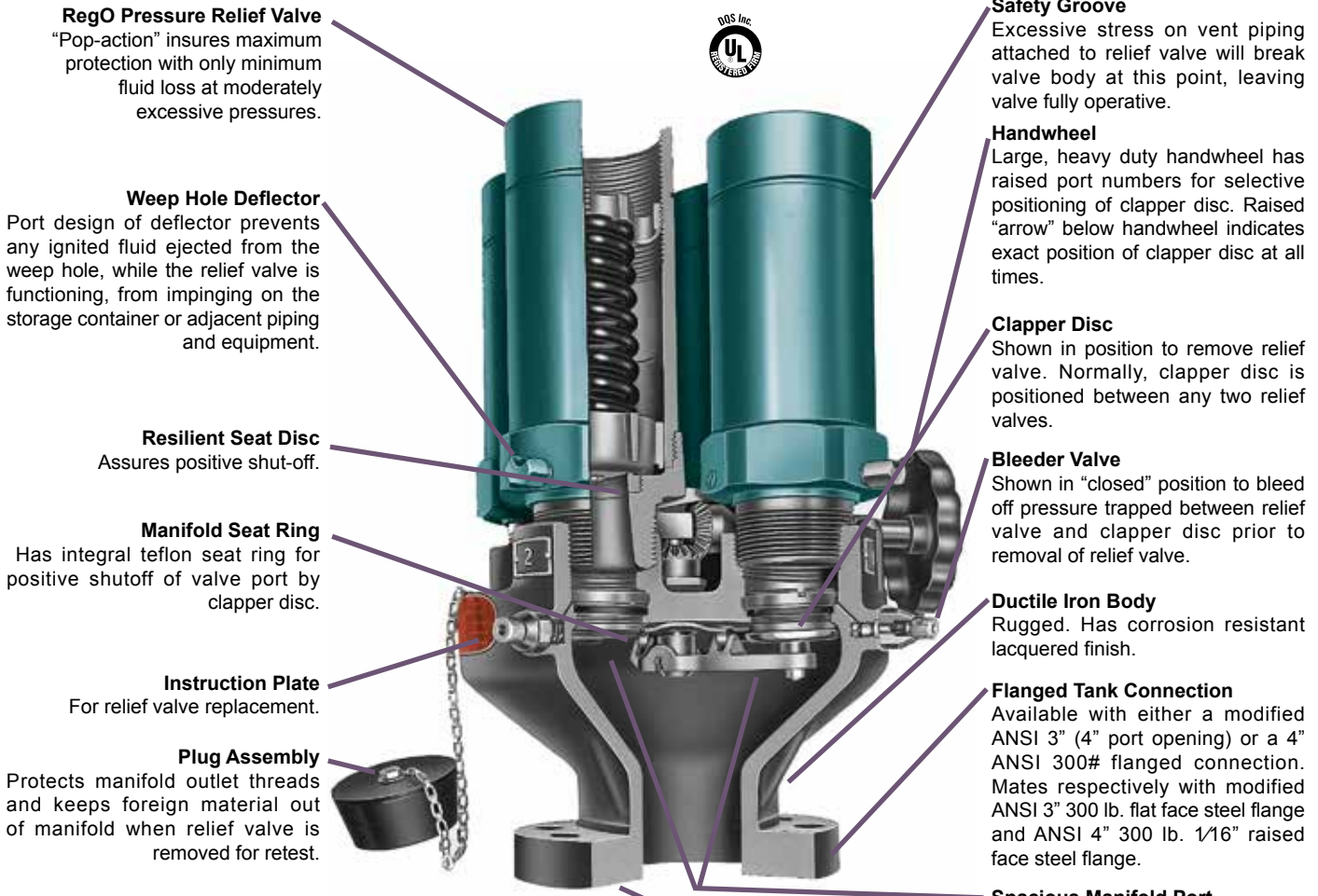

RegO Pressure Relief Valve
"Pop-action" insures maximum protection with only minimum fluid loss at moderately excessive pressures.

Weep Hole Deflector
Port design of deflector prevents any ignited fluid ejected from the weep hole, while the relief valve is functioning, from impinging on the storage container or adjacent piping and equipment.

Resilient Seat Disc
Assures positive shut-off.

Manifold Seat Ring
Has integral teflon seat ring for positive shutoff of valve port by clapper disc.

Instruction Plate
For relief valve replacement.

Plug Assembly
Protects manifold outlet threads and keeps foreign material out of manifold when relief valve is removed for retest.

Safety Groove
Excessive stress on vent piping attached to relief valve will break valve body at this point, leaving valve fully operative.

Handwheel
Large, heavy duty handwheel has raised port numbers for selective positioning of clapper disc. Raised "arrow" below handwheel indicates exact position of clapper disc at all times.

Clapper Disc
Shown in position to remove relief valve. Normally, clapper disc is positioned between any two relief valves.

Bleeder Valve
Shown in "closed" position to bleed off pressure trapped between relief valve and clapper disc prior to removal of relief valve.

Ductile Iron Body
Rugged. Has corrosion resistant lacquered finish.

Flanged Tank Connection
Available with either a modified ANSI 3" (4" port opening) or a 4" ANSI 300# flanged connection. Mates respectively with modified ANSI 3" 300 lb. flat face steel flange and ANSI 4" 300 lb. 1/16" raised face steel flange.

Spacious Manifold Port
Passages large unobstructed throat ensures minimum capacity loss. Manifold is bolted directly to storage container opening, eliminating any restrictions.

Gasket
Johns-Manville Flexitallic flange gasket furnished with each manifold assembly.



Flange Dimensions

Manifold Series	Flange Size	Flange Drilling	Port Diameter	Flange Gasket
A8560	Modified 3" 300# (4" Port Dia)	(8) 7/8" Bolt Holes on a 6 3/8" Bolt Circle Diameter Flat Faced.	4"	3" 7564-48
A8570 AA8570	4" ANSI 300#	(8) 7/8" Bolt Holes on a 7 1/8" Bolt Circle Diameter 1/16" Raised Faced.	4"	4" 7565-48

Ordering Information

Part Number	Start To Discharge Setting PSIG	Application		Container Flange Connection	Quantity	Relief Valve			Flow Capacity SCFM/Air** At 120% of Set Pressure														
		LP-Gas	NH ₃			Part Number	Inlet Connection M. NPT	Accessories	UL Rating	ASME Rating													
A8563G	250	Yes	Yes	3"-300#*	3	A3149MG	2 1/2"	****		18,500 (2)	Not Applicable												
A8564G					4					27,750 (3)													
A8573G				4"-300#	3					18,500 (2)													
A8574G					4					27,750 (3)													
A8563AG				3"-300#*	No	No				3	A3149G	2 1/2"	****		18,300 (2)	27,400 (3)							
A8564AG										4					27,400 (3)								
A8573AG										4"-300#	No				No		3	A3149G	2 1/2"	****		18,300 (2)	27,400 (3)
A8574AG																	4					27,400 (3)	

* For use with modified 300# ANSI flange with 4" port.
 ** Flow rating based on number of relief valves indicated in parentheses ().
 Flow rates shown are for bare relief valves. Adapters and pipeways will reduce flow rates as discussed in the Foreword section.
 *** 2" F. NPT outlet connection.
 **** Outlet 3 1/2-8N (F) thread, will accept 3" M. NPT pipe thread.

Adhesive Warning Label

8545-500

The following warning information, Part Number 8545-500, is included with each shipment of pressure relief valves and relief valve manifolds to the first purchaser of the product from the factory.

This information is intended to be forwarded throughout the product distribution chain. Additional copies are available from RegO and Authorized Product Distributors.

Part Number	
8545-500	Adhesive Warning Label

DANGER	READ THIS FIRST	WARNING
LP-GAS IS EXTREMELY FLAMMABLE AND EXPLOSIVE		
<p>AVOID SERIOUS INJURY AND PROPERTY DAMAGE. IF YOU SEE, SMELL OR HEAR ESCAPING GAS...EVACUATE AREA IMMEDIATELY! CALL YOUR LOCAL FIRE DEPARTMENT! DO NOT ATTEMPT TO REPAIR. DO NOT STORE IN BUILDING OR ENCLOSED AREA. DO NOT USE ON HOT AIR BALLOONS OR AIRCRAFT.</p> <p>Make sure you are thoroughly trained before you attempt any pressure relief installation or maintenance. Improper conditions or procedures can cause accidents resulting in property damage and personal injury.</p> <p>Become thoroughly familiar with NFPA Safety Pamphlet 306 "LP-Gas Regulator and Valve Inspections & Maintenance" and RegO Safety Warning "Pressure Relief Valves" found in the relief valve section of the L-500 & L-102 Catalogs. Follow its recommendations.</p> <p>Know and understand NFPA Pamphlet 58 "Liquefied Petroleum Gas Code", which is the law in many states. This publication is available from NFPA, Batterymarch Park, Quincy, MA 02269. Following its requirements is essential in the safe use of LP-Gas. Section 4.4 states: "Persons who transfer liquid LP-Gas, who are employed to transport LP-Gas, or whose primary duties fall within the scope of this code shall be trained in proper handling procedures. Refresher training shall be provided at least every three years and shall be documented."</p> <p>Make sure this valve is the proper one for this installation. Avoid misusing LP-Gas equipment. Flow rates in the charts are for bare relief valves found in the relief valve section of the L500 & L102 Catalogs. The addition of deflectors, pipeway adapters and piping will restrict the flow. To properly protect any container, the total system flow must be sufficient to relieve pressure at the pressure setting of the relief valve in accordance with all applicable codes.</p> <p>Use only RegO adapters on RegO relief valves. Adapters not designed specifically for piping away RegO relief valves, such as those with 90° turns or reduced internal diameters, will decrease flow dramatically. These should never be used as they can cause the relief valve to chatter and eventually destroy itself.</p> <p>Apply thread joint compound compatible with LP-Gas on valve external threads only. Make sure compound never comes into contact with other parts of the valve.</p> <p>Install valves by applying force to wrenching flats only.</p> <p>Tighten pipe threads approximately 1 to 1½ turns beyond the hand-tight insertion point using a wrench which avoids damage to other valve parts.</p> <p>Check for damage after valve installation. Check that the pressure relief valve is clean and free of foreign material. Make sure protective cap is properly in place.</p> <p>Check that there are no leaks with a non-corrosive leak detection solution before filling with LP-Gas.</p> <p>Purge container before filling with LP-Gas (refer to the RegO LP-Gas Serviceman's Manual for recommended procedure.)</p> <p>In selecting a label for posting at the installation site, consider RegO part number 901-400 along with your own, NFPA's and others.</p> <p>Remember to instruct the owner/user/customer in safety matters concerning LP-Gas and this equipment. See RegO Safety Warning "Pressure Relief Valves" found in the relief valve section of the L-500 & L-102 Catalogs.</p>		
<p>RegO requests that this information be forwarded to your customers. Additional copies are available from RegO and your authorized RegO Distributor.</p>		
		<p>Printed in USA 07A-0910-0386 Part number 8545-500</p>
<p>Elon, N.C. 27244 U.S.A. Phone (336) 449-7707 Fax (336) 449-6594 www.regoproducts.com</p>		

8545-500

D

Section E
Globe and Angle Valves

E

Limited 10 Year Warranty and Limitation Of Liability

LIMITED 10 YEAR WARRANTY

RegO warrants to the original purchasers the products and repair kits manufactured by it to be free from defects in materials and workmanship under normal use and service for a period of 10 years from the date of manufacture. If within thirty days after buyer's discovery of what buyer believes is a defect, buyer notifies in writing and ships the product to RegO at 100 RegO Drive, Elon, NC 27244, RegO, at its option, and within forty-five days of receipt, will repair, replace F.O.B. point of manufacture, or refund the purchase price of that part or product found by RegO to be defective. Failure of buyer to give such written notice and ship the product within thirty days shall be deemed an absolute and unconditional waiver of any and all claims of buyer arising out of such defect.

This warranty does not extend to any product or part that is not installed and used after installation in accordance with RegO's printed instructions, all applicable state and local regulations, and all applicable national standards, such as those promulgated by NFPA, DOT and ANSI. This warranty does not extend to any product or part that has been damaged by accident, misuse, abuse, failure to maintain, or neglect, nor does it extend to any product or part which has been modified, altered, disassembled, or repaired in the field. This warranty does not cover any cosmetic issues, such as scratches, dents, marring, fading of colors or discoloration.

Except as expressly set forth above, and subject to the limitation of liability below, RegO MAKES NO OTHER WARRANTY, EXPRESS OR IMPLIED, INCLUDING, BUT NOT LIMITED TO, THE IMPLIED WARRANTIES OF MERCHANTABILITY AND FITNESS FOR A PARTICULAR PURPOSE, with respect to its products and parts, whether used alone or in combination with others. RegO disclaims all warranties not stated herein.

LIMITATION OF LIABILITY

RegO's total liability for any and all losses and damages arising out of any cause whatsoever shall in no event exceed the purchase price of the products or parts in respect of which such cause arises, whether such cause be based on theories of contract, negligence, strict liability, tort or otherwise.

RegO shall not be liable for incidental, consequential or punitive damages or other losses. RegO shall not be liable for, and buyer assumes any liability for, all personal injury and property damage connected with the handling, transportation, possession, further manufacture, other use or resale of products, whether used alone or in combination with any other products or materials.

From time to time buyers might call to ask RegO for technical advice based upon limited facts disclosed to RegO. If RegO furnishes technical advice to buyer, whether or not at buyer's request, with respect to application, further manufacture or other use of the products and parts, RegO shall not be liable for such technical advice or any such advice provided to buyer by any third party and buyer assumes all risks of such advice and the results thereof.

NOTE: Some states do not allow the exclusion or limitation of incidental, consequential or punitive damages, so the above limitation or exclusion may not apply to you. The warranty gives you specific legal rights, and you may have other rights that vary from State to State. The portions of this limited warranty and limitation of liability shall be considered severable and all portions which are not disallowed by applicable law shall remain in full force and effect.

WARNING

All RegO products are mechanical devices that will eventually become inoperative due to wear, corrosion and aging of components made of material such as rubber, etc. The environment and conditions of use will determine the safe service life of these products. Periodic inspection and maintenance are essential to avoid serious injury and property damage.

Many RegO products are manufactured components which are incorporated by others on or in other products or systems used for storage, transport, transfer and otherwise for use of toxic, flammable and dangerous liquids and gases. Such substances must be handled by experienced and trained personnel only, using accepted governmental and industrial safety procedures.

NOTICE TO USERS OF PRODUCTS

The Limited Warranty stated above is a factory warranty to the first purchasers of RegO products. Since most users have purchased these products from RegO distributors, the user must within thirty (30) days after the user's discovery of what user believes is a defect, notify in writing and return the product to the distributor from whom he purchased the product/part. The distributor may or may not at the distributor's option choose to submit the product/parts to RegO, pursuant to this Limited Warranty. Failure by buyer to give such written notice within thirty (30) days shall be deemed an absolute and unconditional waiver of buyer's claim for such defects. Acceptance of any alleged defective product/parts by RegO's distributor for replacement or repairs under the terms of RegO's Limited Warranty in no way determines RegO's obligations under this Limited Warranty.

Because of a policy of continuous product improvement, RegO reserves the right to change designs, materials or specifications without notice.

Foreword

This catalog describes a complete line of equipment available from RegO® for use with Liquid Propane (LP)-Gas and anhydrous ammonia (NH₃). The following points are important to know for proper use of the catalog:

1. Illustrations and drawings of individual products are representative of “product groups” and all products within a product group are similar in construction.
2. Materials used for construction of products in this catalog are suitable for rated service pressure at temperatures of -40°F to +165°F, unless otherwise specified.
3. Products in this catalog are only intended for use in LP-Gas and/or anhydrous ammonia service as follows.
 - a. “A” or “AA” prefix — Products with this prefix are suitable for NH₃ service (i.e., contain no brass parts).
 - b. “AA” prefix on relief valves — These valves are NOT suitable for use with LP-Gas service. These are of partial aluminum materials and are listed by Underwriters Laboratories (UL) for NH₃ service only.
 - c. All other products including “A” prefix are suitable for use with LP-Gas & NH₃ service.
 - d. “SS” prefix—Hydrostatic relief valve with this prefix are suitable for NH₃ and LP-Gas service (i.e., they have stainless steel materials).
4. We manufacture valves and adapters designed to be used on LP-Gas and Anhydrous Ammonia systems, we do not design systems or consult in system design. For this type of information consult a professional Engineer.

Caution

Do not use any product contained in this catalog with any service commodity other than LP-Gas or NH₃. If you have a need for use of another application, contact RegO, 100 RegO Drive, Elon, NC 27244, (336) 449-7707 ecii@regoproducts.com before proceeding.

Proper application, installation and maintenance of products in this catalog are essential. Users of these products should obtain further information if there are any doubts or questions.

Warning

All RegO products are mechanical devices that will eventually become inoperative due to wear, corrosion and aging of components made of materials such as rubber. The environment and conditions of use will determine the safe service life of these products. Periodic inspection and maintenance are essential to avoid serious injury and property damage.

Many RegO products are manufactured for storage, transport, transfer and use of toxic flammable and dangerous liquids and gases. Such substances should be handled by experienced and trained personnel only, using accepted governmental and industrial safety procedures. Never vent LP-Gas near any possible source of ignition.

Notice

Installation, usage, and maintenance of all RegO products must be in compliance with all RegO instructions as well as requirements and provisions of NFPA #54, NFPA#58, DOT, ANSI, and all applicable federal, state, provincial and local standards, codes, regulations, and laws.

Inspection and maintenance on a periodic basis is essential. Installation and maintenance should be performed only by qualified personnel.

Be sure all instructions are read and understood before installation, operation and service.

Filters

RegO LP-Gas equipment is designed to operate in a system free from contamination. A variety of in-line filters are commercially available to the LP-Gas industry for installation in domestic systems.

The use of an in-line filter should be considered when other system components may be unclean and the system contaminated by rust, scale, dirt, debris or other foreign material.

LP-Gas Hose-End Filling Valves (With ACME Connectors)

Safety Warnings



Purpose

In its continuing quest for safety, RegO publishes a series of bulletins explaining the hazards associated with the use, misuse, and aging of LP-Gas valves and regulators. It is hoped that these factual bulletins will make clear to LP-Gas dealer managers and service personnel, that the utmost care and attention must be used in the installation, inspection, and maintenance of these products, or problems could occur which would result in injuries and property damage.

The National Fire Protection Association NFPA 58 Liquefied Petroleum Gas Code - 2017 Edition states in Section 4.4 Qualification of Personnel; "Persons whose duties fall within the scope of this code shall be provided with training that is consistent with the scope of their job activities and that includes proper handling and emergency response procedures. Refresher training shall be provided at least every 3 years, initial and subsequent training shall be documented". These "RegO Safety Warnings" may be useful in training new employees and reminding older employees of hazards that can occur. It is recommended that all employees complete the Propane Education Research Council's Certified Employee Training Program.

Nature of Warnings

It is recognized that warnings should be as brief as possible, but factors involved in filler valve and filling valves failure are not simple. They need to be fully understood so that proper procedures and maintenance can be used to prevent accidents. If there is a simple warning, it would be:

Loosen filling valve from filler valve very slowly. If there is a leak, know procedure to follow.

This bulletin is not intended to be an exhaustive treatment of the subject of filler valves and certainly does not cover all safety practices that should be followed in the installation, operation and maintenance of LP-Gas systems, which include filler and filling valves.

Hose-End Filling Valves With ACME Connectors

Hose-end valves must never be dragged over the ground or dropped or banged into the truck when the hose is reeled in.

They could open accidentally or they could be damaged. Dragging will cause abnormal wear and eventual valve failure. Foreign material will lodge in the connector which can cause failure of the filler valve.

To prevent hazardous conditions, operators should follow this procedure on every filling application:

Always wear gloves and eye protection.

Check for foreign material in hose-end valve and the filler valve, and if present, remove with extreme care. If material cannot be safely removed, do not proceed with filling and replace valve.

Make sure the ACME connector spins on easily by hand.

If leak is noticed when filling is started, stop the operation and correct the leaking condition.

After filling, bleed the gas trapped between the filler valve and hose-end valve by using the vent on the hose-end valve or by slightly loosening coupling nut to vent the gas before disconnecting.

If gas does not stop venting, then filler valve or hose-end valve is leaking. Do not disconnect filling connector. This is a hazardous situation and your company procedure for handling this problem must be carefully followed.

Make sure your company has such a procedure. Inspection of Filling Valves with Handwheel

Valves should be inspected at least once a month to be sure that the valve handle is tight and not damaged, that the stem is not bent and that there is no "play" in the threads in the bonnet. "Play" will normally not be noticed if the valve is under pressure.

The ACME threads should be examined for wear, dents or nicks and the seating area should be clean and smooth.



Loosen slowly. If gas continues to vent, retighten ACME connector and follow company emergency procedures.

Inspection of Quick Acting Filling Valves

Valves should be inspected daily to make sure locking mechanism functions properly.

The ACME threads should be examined for wear, dents or nicks and the seating area should be clean and smooth.

The retaining ring on the filler connection should be examined to make sure it is properly holding the female ACME rotating nut or handle so as to keep the surface that seats on the filler valve gasket protected.

If any problems are evident, valves should be immediately replaced or repaired.

Larger Filler and Filling Valves

For 2¼" and 3¼" valves with ACME connections, use only the special wrenches designed for the purpose.

Do not use pipe wrenches or hammers to tighten the connections. All of the previous warnings about the smaller valves also apply here.

General Warning

All RegO products are mechanical devices that will eventually become inoperative due to wear, contaminants, corrosion and aging components made of materials such as rubber and metal. The environment and conditions of use will determine the safe service life of these products. Periodic inspection and maintenance are essential. Because RegO products have a long and proven record of quality and service, LP-Gas dealers may forget the hazards that can occur because a filler valve or a filling valve is used beyond its safe service life. Life of these valves is determined by the environment in which they "live." The LP-Gas dealer knows better than anyone what this environment is. Note: There is a developing trend in state legislation and in proposed national legislation to make the owner of products responsible for replacing products before they reach the end of their safe useful life. LP-Gas dealers should be aware of the legislation which could affect them.

Quick-Acting Minimum Loss Hose-End Valves for Bobtail Delivery Trucks and Dispensing Stations A7793A and A7797A

Application

Designed to vastly reduce the amount of product vented when disconnecting bobtail delivery trucks, dispensing systems and anhydrous ammonia nurse tanks. These valves provide instant, full-on flow at the flip of a handle. Shut-off is instant and the handle locks for added protection. This "top of the line" hose-end valve is a fully contained unit that does not require additional filling adapters or connectors.

Features

- Minimizes product venting loss, when disconnecting, instantly by housing the seat disc at the bottom of the built-in ACME filling connector.
- Vents less than 2cc of liquid when disconnected.
- "V"-ring spring-loaded pressure seal design provides for dependable, leak-free operation. No packing to retighten or replace.
- Operator friendly. Contoured handle rotates a full 360° and large, easy to grip filling connector make the valve easy to handle.
- Self locking handle is operator opened and closed to prevent against accidental opening of the valve.

Materials

Body	Ductile Iron
"V"-Ring	Teflon
Stem	Stainless Steel
Seat Disc	Synthetic Elastomer
ACME Connector.....	Aluminum w/Steel Insert
Seal Housing	Stainless Steel
Lever.....	Stainless Steel
Bonnet	Cadmium Plated Steel



A7793

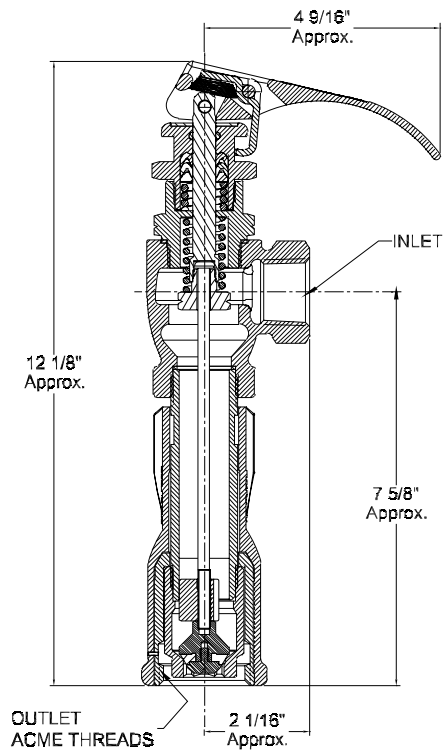

Ordering Information

Part Number	Inlet Connection (F. NPT)	Outlet Connection (F. ACME)	Locking Handle	Flow at 1 PSIG (Cv) Pressure Drop* (GPM/Propane)
A7793A	3/4"	1 3/4"	Yes	16.0
A7797A	1"	1 3/4"	Yes	16.0

* To obtain approximate flow at other than 1 PSIG pressure drop, multiply flow in table by square root of pressure drop. Example: A7797 @ 9 PSIG = 16.0 x√9 = 48.0 GPM/propane. For NH₃ flow, multiply propane flow by .90.

Quick-Acting Hose-End Valves for Bobtail Delivery Trucks and Dispensing Stations A7707L and A7708L

Application

Designed especially for safe operator handling of LP-Gas in bobtail delivery truck, dispensing systems and anhydrous ammonia nurse tank service.

These valves provide instant, full-on flow at the flip of the handle and provide instant positive shut-off with a handle lock for added protection.

Features

- "V"-ring spring-loaded pressure stem seal provides for leak-proof operation. No packing to retighten or replace.
- Self locking handle is operator opened and closed to prevent against accidental opening of the valve.
- Large, contoured handle provides firm, comfortable grip.
- Full swivel handle rotates 360° so the valve can be operated from any angle.
- Built-in vent valve on the downstream side of the valve permits bleeding of trapped product to ensure safe uncoupling.
- Can be used with a variety of RegO filling adapter connectors.
- Swivel seat disc minimizes grinding on the body seat and ensures longer service life.

Materials

Body	Ductile Iron
"V"-Ring	Teflon
Stem	Stainless Steel
Seat Disc	Synthetic Elastomer
Valve Lever	Stainless Steel
Seal Housing	Stainless Steel
Bonnet	Cadmium Plated Steel

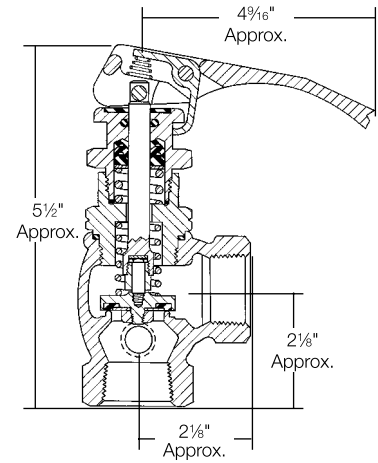
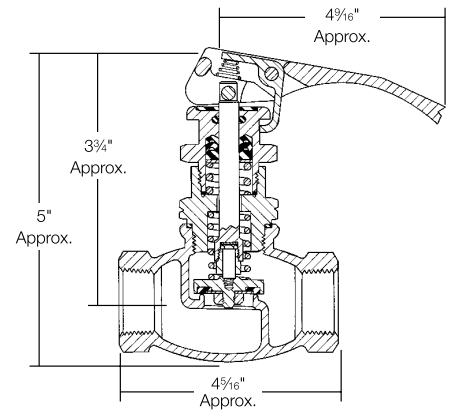

E

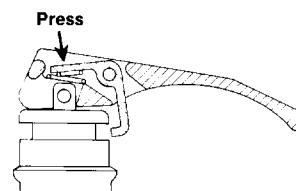

Spring-Loaded Thumb-Button Opens Latch

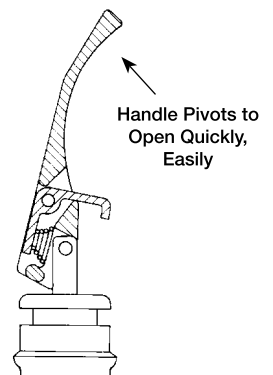

Ordering Information

Part Number	Body Design	Inlet & Outlet Connection (F. NPT)	Locking Handle	Flow at 1 PSIG Pressure Drop (Cv) (GPM/Propane)**	Accessories		
					Filling Connectors**		
					Extended Steel	Compact	
						Brass	Steel
A7707L	Straight	1"	Yes	18.0	A7575L4	3175A	A3175A
A7708L	Angle			22.0			

* To obtain approximate flow at other than 1 PSIG pressure drop, multiply flow in table by square root of pressure drop. Example: A7708L @ 9 PSIG = 22.0 x √9 = 66.0 GPM/propane. For NH₃ flow, multiply propane flow by .90.

** See appropriate catalog section for additional information.

New 2" ACME Low Emission Hose End Valve for Loading Bobtails and Transports A7914A

Application

The A7914A Low Emission valve is designed to reduce the amount of product vented when disconnecting bobtail and transport loading hoses. This valve provides a full-on flow when pressing the release trigger and the lifting of an easy grip handle. Lowering the handle will immediately stop flow and lock the lever in the closed position. This valve can be used with any standard 3/4" Male ACME connector, or our 6588LE and 6589LE minimum loss filler valves.

Features

- Minimizes product discharge at disconnect.
- Vents **less than 2 cc of liquid** when disconnected.
- **California CARB Compliant for fugitive emissions.**
- Contoured handle rotates 360° and has a large easy to turn ACME swivel connector.
- Self-locking handle is operator opened and closed, designed to prevent accidental opening of the valve.
- Bypass mechanism in the seat area allows the upstream pressure to quickly equalize when the handle is partially moved to the open position.
- Protective screen on inlet side prevents debris from entering.
- Spring-loaded Teflon "V" packing for bonnet/stem assembly provides long service life.

Materials

Body	Ductile Iron
"V" -Rings.....	Teflon
Stem	Stainless Steel
Acme Connector.....	Plated Ductile Iron
Seal Housing	Stainless Steel
Bonnet	Plated Steel
Lever.....	Stainless Steel
Seat Disc	Synthetic Rubber



A7914A

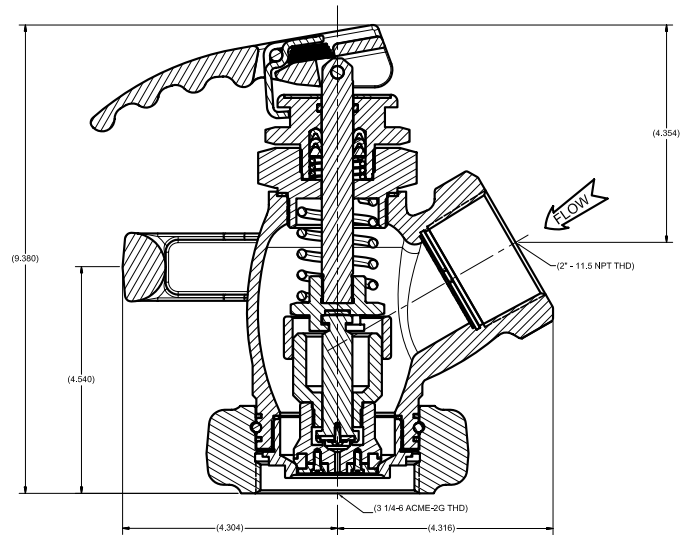

Ordering Information

Part Number	Inlet Connection	Outlet Connection	Locking Handle	Flow at (Cv) Pressure Drop GPM Propane	
				1 PSIG	10 PSIG
A7914A	2" F.NPT	3/4" F.Acme	Yes	55	174

*To obtain approximate flow at other than 1 PSIG drop, multiply flow in table by square root of pressure drop. Example A7914 @ 9PSIG drop = 55 X $\sqrt{9}$ = 165 GPM /propane

Quick-Acting Valves for Crop Driers and Charging Manifold Hoses

7554 Series

Application

7554S Series valves provide instant shut-off and fast opening control on LP-Gas crop driers. They are also ideal for charging manifold hoses, stationary fuel transfer hoses and other applications requiring quick, positive shut-off. They are not for use with delivery truck hoses because the handle could snag on the ground and open the valve as the hose is reeled back to the truck.

7554L Series valves feature a locking handle device to help prevent accidental opening of the valve. It is ideal for all the same applications as the 7554S Series and may be used on delivery trucks as it incorporates the locking handle design.

Both valve series must be installed so that flow through the valve is opposite to that of a conventional globe valve. This allows the inlet flow to assist in closing the valve and prevents the valve from being opened by high pump pressures.

Features

- Quick-acting design speeds transfer operations, permitting rapid, one-handed opening and closing.
- Resilient seat disc provides positive shut-off.
- Flange seal stem design provides for leak-proof operation. No packing to retighten or replace.
- 7554L Series incorporates locking handle to prevent accidental opening of the valve.
- Vent valve installed on the downstream side of the valve permits bleeding of trapped product to ensure safe uncoupling.
- Swivel seat disc minimizes grinding on the body seat and ensures longer service life.

Materials

Body	Ductile Iron
Bonnet	Brass
Stem Seal	Teflon
Stem	Stainless Steel
Seat Disc	Nitrile Elastomer
Seal Housing	Brass
Lever	Brass



7554S

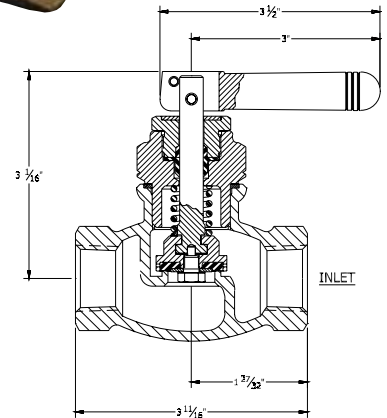

7554LV

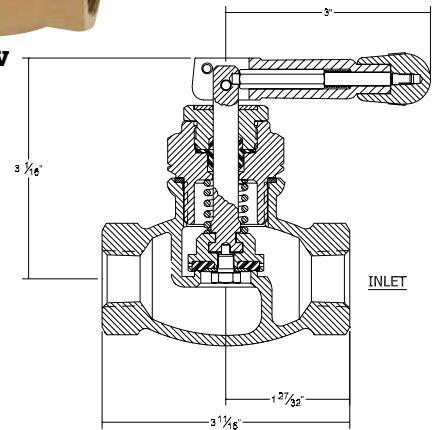

Ordering Information

Part Number	Inlet & Outlet Connection (F. NPT)	Locking Handle	Flow At 1 PSIG (Cv) Pressure Drop* (GPM/Propane)
7554SAV	1/2"	No	7.3
7554LAV		Yes	
7554SV	3/4"	No	11.3
7554LV		Yes	

* To obtain approximate flow at other than 1 PSIG pressure drop, multiply flow in table by square root of pressure drop. Example: 7554LV @ 9 PSIG = 11.5 X $\sqrt{9}$ = 34.5 GPM/propane.

Quick-Acting Valves for Cylinder Charging Hoses 7053T and 7901T Series

Application

Designed primarily for use on cylinder charging hoses to provide fast, convenient shut-off and fast opening.

These valves must be installed so that flow through the valve is in the opposite direction to that of a conventional globe valve. This allows the inlet flow to assist in closing the valve, and even more important, helps prevent the valve from being forced open by high pump pressure.

Features

- Quick-acting design speeds transfer operations.
- Permits easy, one-handed opening and closing of the valve.
- O-ring stem seal design.
- Provides quick, positive shut-off.

Materials

Body (7053T, 7901) Forged Brass
 O-Ring Resilient Synthetic Rubber
 Bonnet Assembly (7053T, 7901)..... Brass
 Seat Disc Resilient Synthetic Rubber
 Handle (7053T, 7901)..... Brass
 Springs Stainless Steel



7901T

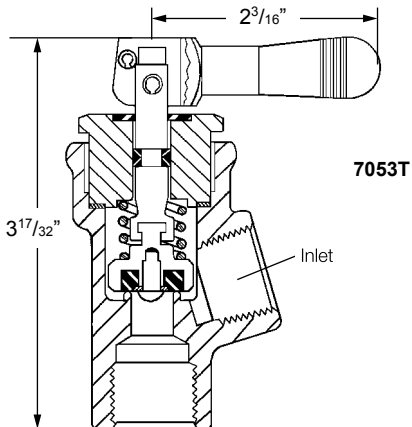
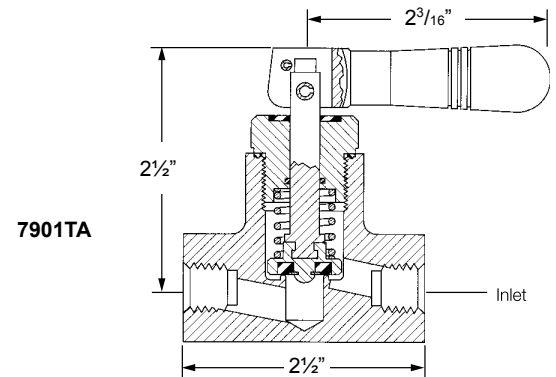

Ordering Information

Part Number	Inlet Connection (F. NPT)	Outlet Connection (F. NPT)	Body Material	Flow At 1 PSIG (CV) Pressure Drop* (GPM/Propane)
7901T	1/4"	1/4"	Brass	1.95
7901TA	3/8"	3/8"		
7901TB	1/2"	1/4"		
7901TC		1/2"		
7053T		1/2"		

* To obtain approximate flow at other than 1 PSIG pressure drop, multiply flow in table by square root of pressure drop. Example: 7901T @ 9 PSIG = $\sqrt{9} \times 1.95 = 5.85$ GPM/propane. For NH3 flow, multiply propane flow by .90.

Quick-Acting Valves for Dispensing Hoses 7901TL Series

Application

Designed primarily for use on dispensing hoses to provide safe, convenient shut-off and fast opening. These valves feature a locking handle device to help prevent accidental opening of the valve.



Features

- Quick-acting design speeds transfer operations.
- Permits easy, one-handed opening and closing of the valve.
- O-ring stem seal design.
- Provides quick, positive shut-off.
- Locking handle device is operator opened and closed to prevent against accidental opening of the valve.



7901TL Series

Materials

Body	Forged Brass
O-Ring	Resilient Synthetic Rubber
Bonnet Assembly	Brass
Seat Disc	Resilient Synthetic Rubber
Handle	Brass
Springs	Stainless Steel



Ordering Information

Part Number	Inlet Connection (F. NPT)	Outlet Connection (F. NPT)	Body Material	Flow At 1 PSIG (CV) Pressure Drop* (GPM/Propane)
7901TLA	3/8"	3/8"	Brass	1.95
7901TLB	1/2"	1/4"		
7901TLC		1/2"		

* To obtain approximate flow at other than 1 PSIG pressure drop, multiply flow in table by square root of pressure drop. Example: 7901T @ 9 PSIG = 1.95 x $\sqrt{9}$ = 5.85 GPM/propane. For NH3 flow, multiply propane flow by .90.

Quick-Acting Valves for Dispensing Hoses with Low Emission Hose End Safety Adapter 7993 Series

Application

Designed primarily for use on dispensing hoses to provide fast, convenient shut-off and fast opening with minimal release of product on disconnect.



Ordering Information

Part Number	Inlet Connection (F. NPT)	Outlet Connection (F. NPT)	Body Material
7993AD-10L	3/8"	M. POL (CGA 510)	Brass
7993AU-10L		Type 1 Connection (1 ⁵ / ₁₆) F. ACME	
7993BD-10L		M. POL (CGA 510)	
7993BU-10L	1/2"	Type 1 Connection (1 ⁵ / ₁₆) F. ACME	
7993CD-10L		M. POL (CGA 510)	
7993CU-10L		Type 1 Connection (1 ⁵ / ₁₆) F. ACME	

“V”-Ring Seal Globe and Angle Valve Information

General Information

RegO Globe and Angle Valves are designed and manufactured especially to meet the rigid requirements of the LP-Gas industry. The high quality construction and wide variety of sizes and styles also make them highly suited to many other industries such as anhydrous ammonia, chemical and petrochemical.

These ductile iron valves are available in both threaded and flanged connections. Threaded connections are available in ½” F. NPT to 3” F. NPT sizes. Flanged connections are available in 1½”, 2” and 3” pipe sizes.

The ductile iron used in these valves has a 60,000 PSIG tensile strength which closely approaches that of steel castings. Its yield strength of 45,000 PSIG and elongation of 15% is also comparable to that of steel castings. These material features ensure the ability of the valve body to withstand impact, wrenching stresses and thermal shock. This ductile iron conforms to ASTM specification A395.

RegO globe and angle valves are designed for working pressures up to 400 PSIG WOG and for operating temperatures from -40° F. to +160° F.

“V”-Ring Stem Seal

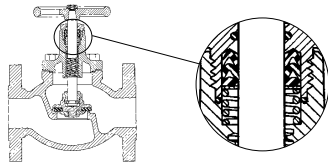

The “V”-ring spring-loaded pressure seal used in these RegO globe and angle valves is the most effective stem seal yet developed. It should not be confused with conventional valve stem packing where the seal is obtained by compressing the packing around the stem by means of a packing gland with resultant hard operation and frequent packing replacement.

The wax like surface of the teflon “V”-ring seal and consequent low friction ensures leak-tight performance for an indefinite period where periodic retightening of the packing is not required and the seal provides extra long service life.

In the RegO “V”-ring design, the seal is effected by the pressure expanding the “V”-shape of the seal, forcing it against the stem and bonnet surfaces to prevent leakage. The higher the pressure within the valve, the more effective the seal becomes. A spring loaded washer under the “V”-rings keeps them in an expanded position to ensure an effective seal under low pressure conditions. A wiper ring, located above the seal, keeps the seal free from grit, and/or other foreign material that may hamper operation.

Installation and Operation Note

Containers and pipe lines should be thoroughly cleaned before globe and angle valves are installed. Large particles of solid foreign matter can permanently damage the seating surface in the valve body, causing the valve to leak. Use a minimum amount of a suitable pipe dope on the male connecting threads as excess amounts may fall off and be carried into the valve, causing damage to the seat or other operating parts.

It is totally unnecessary to use excess force in opening or closing RegO valves. The type of seat disc material used and the general design of these valves permits them to be opened and closed easily. Proper valve operation insures unusually long life.

Wrenches must never be used to operate valves equipped with handwheels and designed for hand operation.

Downstream Accessory Boss

These RegO valves incorporate a plugged ¼” F. NPT boss on the downstream side of the body for attaching either a hydrostatic relief valve or vent valve. Boss size on the 2” and 3” valves has been increased to allow a ¾” drilling for accommodation of a standard by-pass valve or jumper lines.

Hydrostatic Relief—When the design of the piping installation is such that liquid may be locked between two shut-off valves, a hydrostatic relief valve should be installed in the lines between the valves. The pressures which can develop due to temperature increase in a liquid fill line are tremendous and can easily damage the valves or piping unless a hydrostatic relief valve is installed.

Vent Valve—If the globe or angle valve is used as a shut-off valve on a loading hose, a vent valve should be installed in the downstream boss to allow liquid trapped beyond the shut-off valve to be vented before disconnecting the hose coupling.

Replace Gate Valves with Flanged Valves

Except for standard flange sizes, RegO Flanged Globe and Angle Valves are smaller and lighter than contemporary valves, thus reducing price and shipping costs and making them far easier to install. RegO face-to-face flange dimensions conform to gate valve dimensions, making replacement of most gate or plug valves with RegO valves simple and easy.

General Features

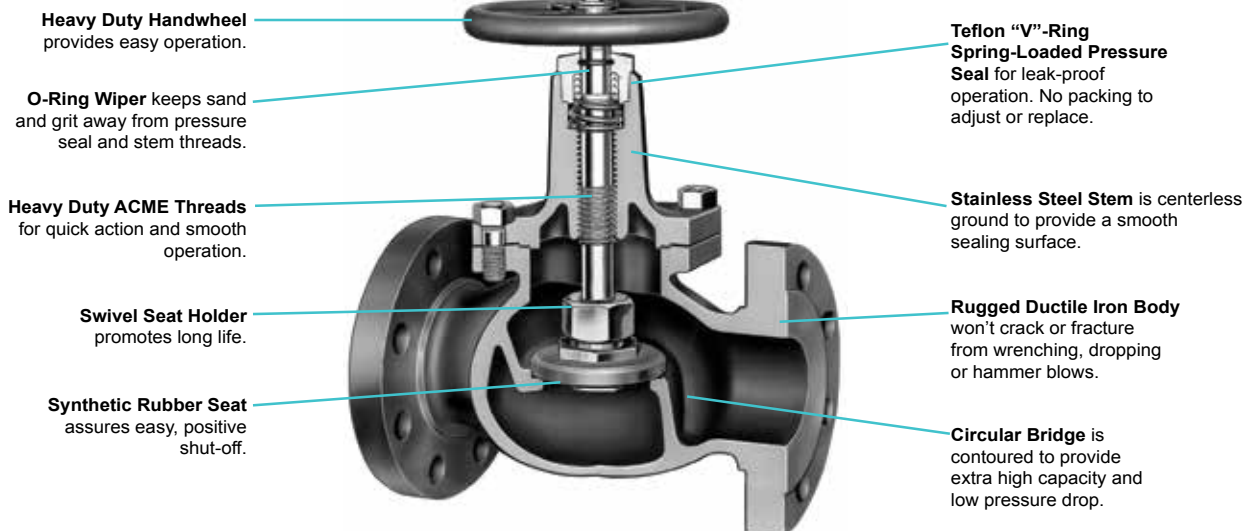

"V"-Ring Seal Globe and Angle Valves for Bulk Storage Containers, Transports, Bobtails and Plant Piping A7500 Series and TA7500 Series

Application

Specifically designed to ensure positive shut-off and long, maintenance free service life in liquid or vapor service on bulk storage containers, transports, bobtails, cylinder filling plants and plant piping.

The high quality construction and wide variety of sizes make them highly suited for use with LP-Gas, anhydrous ammonia and in the chemical and petrochemical industries.

Features

- "V"-ring spring-loaded pressure stem seal provides for leak-proof operation. No packing to retighten or replace.
- Circular bridge in the globe design and a dropped seat in the angle design achieve greater flow with less pressure drop.
- Swivel seat disc assembly minimizes the seat disc from grinding on the body seat. The seat disc stops rotating as soon as it touches the body seat. This feature provides for good seat alignment and ensures long seat life.
- ¼" F. NPT plugged boss on the downstream side of the valve body allows attachment of a hydrostatic relief valve or vent valve.
- "V"-ring stem seal virtually eliminates hard to turn handles frequently encountered with packed type seals.
- Heavy duty rolled ACME stem threads provide quick action and long service life.

Materials

Body Ductile Iron
 Bonnet (7034, 7505-7508)..... Steel
 Bonnet (7509-7518)..... Ductile Iron
 Valve Stem Stainless Steel
 Wiper Ring..... Synthetic Rubber
 Seat Disc..... See Ordering Chart
 "V"-Rings Teflon
 Handwheel..... Ductile Iron
 Spring Stainless Steel



A7518FP



TA7034



A7505AP



A7514AP



A7513AP



A7517AP



A7517FP

Ordering Information

Part Number				Inlet and Outlet Connection	Port Diameter	Flow at 1 PSIG Pressure Drop (Cv) (GPM/Propane)***		Accessories	
Buna N Seat Discs		Teflon Seat Discs*				Globe	Angle	Hydrostatic Relief Valve	Vent Valve
Globe	Angle	Globe	Angle						
-	-	TA7034P	TA7034LP	½" F. NPT	¾"	10.0	14.8	SS8001U	TSS3169
A7505AP	A7506AP	TA7505AP	TA7506AP	¾" F. NPT	1"	12.0	17.7		
A7507AP	A7508AP	TA7507AP	-	1" F. NPT	1¼"	17.8	22.0		
A7509BP	A7510BP	TA7509BP	TA7510BP	1¼" F. NPT	1½"	36.5	54.0		
A7511AP	A7512AP	TA7511AP	TA7512AP	1½" F. NPT	2"	43.0	55.5		
A7511FP	-	TA7511FP	-	1½" Flange**	2"	46.0	-		
A7513AP	A7514AP	TA7513AP	-	2" F. NPT	3"	75.0	88.5		
A7513FP	A7514FP	TA7513FP	TA7514FP	2" Flange**	3"	78.0	133.0		
A7517AP	A7518AP	TA7517AP	-	3" F. NPT	3½"	197.0	303.0		
A7517FP	A7518FP	TA7517FP	-	3" Flange**					

* Teflon seat discs on valves built to order.

** 300# ANSI R.F. Flange.

*** To obtain approximate flow at other than 1 PSIG pressure drop, multiply flow in chart by square root of pressure drop. Example: 7514FP @ 9 PSIG = 133 x 9 = 399 GPM/propane. For NH₃ flow, multiple propane flow by .90.

Globe and Angle Valve Dimensions

Drawing	Valve Number (A or TA Prefix)	Inlet & Outlet	Port Diameter	Dimensions						
				A	B	C	Flanges			G
							D	E	F	
	7034P	1/2" F. NPT	3/4"	4 3/4"	-	3 1/16"	-	-	-	-
	7505AP	3/4" F. NPT				3 1/16"				
	7507AP	1" F. NPT	1"			4 5/16"				
	7034LP	1/2" F. NPT	3/4"	4 3/4"	1 3/4"	-	-	-	-	-
	7506AP	3/4" F. NPT								
	7508AP	1" F. NPT	1"							
	7509BP	1 1/4" F. NPT	1 1/4"	7 41/64"	-	4 7/8"	-	-	-	-
	7511AP	1 1/2" F. NPT	1 1/2"	6 3/4"		5 3/16"				
	7513AP	2" F. NPT	2"	7 7/16"		5 7/8"				
	7517AP	3" F. NPT	3 3/8"	13 1/4"		9"				
	7510BP	1 1/4" F. NPT	1 1/4"	6 3/4"	2 1/4"	-	-	-	-	5 1/4"
	7512AP	1 1/2" F. NPT	1 1/2"	6 13/16"	2 7/16"					
	7514AP	2" F. NPT	2"	7 7/16"	2 11/16"					
	7518AP	3" F. NPT	3 3/8"	11 3/4"	4"					
	7511FP	1 1/2" Flange	1 1/2"	7 9/16"	-	7 1/2"	6 1/8"	3/4"	2 7/8"	5 1/4"
	7513FP	2" Flange	2"	8 7/16"		8 1/2"	6 1/2"	1 3/16"	3 5/8"	
	7517FP	3" Flange	3 3/8"	13 1/4"		11 1/8"	8 1/4"	1 1/8"	5"	
	7514FP	2" Flange	2"	7 1/2"	5 1/4"	-	6 1/2"	1 3/16"	3 5/8"	5 1/4"
	7518FP	3" Flange	3 3/8"	11 1/4"	6 1/4"		8 1/4"	1 1/8"	5"	9"

NOTE: Regarding 7505AP through 7510BP — the thread used for assembling the bonnet to the body of the valve is a left hand thread. We advise our customers to be cognizant of this assembly design in attempting to remove the bonnets of these valves in order to avoid serious damage to the valves.

Flange Dimensions

	Valve Number (A or TA Prefix)	Size		Flange Drilling	D	E	F	H
	7511FP	1 1/2"		7/8" Bolt Holes on a 4 1/2" Bolt Circle Diameter	6 1/8"	1 3/16"	2 7/8"	3/4"
	7513FP	2"		3/4" Bolt Holes on a 5" Bolt Circle Diameter	6 1/2"	7/8"	3 5/8"	1 3/16"
	7514FP							
	7517FP	3"		7/8" Bolt Holes on a 6 5/8" Bolt Circle Diameter	8 1/4"	1 1/8"	5"	1 1/8"
	7518FP							

* Reducing screwed flanges are available for reducing 1 1/2" flange to 1 or 1 1/4" pipe thread and 3" flange to 2 1/2" pipe thread. Order from your local piping supplier.

2" & 3" Globe/Angle valves with Built-in Automatic Back Check HA7513AP/HA7514AP and HA7517AP/HA7518AP

Application

Designed for use in conjunction with our 6588LE and 6589LE low emission filler valves installed on bobtails and transports. The valves are designed to stop flow out of the container when the hand-wheel is closed. They incorporate an automatic integral back check that is designed to allow flow back into the container to prevent liquid from becoming trapped between the 6588/89LE and the closed globe/angle valve.

Features

- V-ring spring loaded pressure stem seal provides for leak-proof operation. No packing to retighten or replace.
- Circular bridge in globe design and a dropped seat in the angle design achieve greater flow with less pressure drop.
- Swivel seat disc assembly minimizes wear which provides for good alignment and long seat life.
- ¼" F.NPT plugged holes on upstream and downstream sides of the valve.
- Heavy duty rolled ACME stem threads provide quick action and long service life.
- Seat Disc assembly incorporates an automatic back check valve, eliminating the need for a separate hydrostatic relief valve.

Materials

Body Ductile Iron
 Stem Stainless Steel
 Seat Stainless Steel
 Seat Disc Synthetic Rubber
 Return Spring Stainless Steel



HA7513AP



HA7514AP

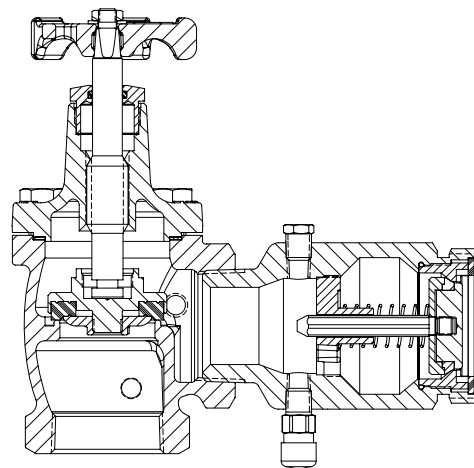

Ordering Information

Part Number		Inlet/Outlet Connection	Port Diameter	Flow at 1 PSIG Pressure drop GPM Propane	
Globe	Angle			Globe	Angle
HA7513AP	HA7514AP	2" -FNPT	2"	75.0	88.5
HA7517AP	HA7518AP	3"-FNPT	3½"	197.0	303.0

Flange Seal Globe and Angle Valve Information

General Information

Globe and Angle Valves, incorporating the synthetic rubber flange seal design, operate on the same principle as the "V"-ring valves. Gas pressure in the valve is exerted against the synthetic rubber flange, forcing it tightly against the stem.

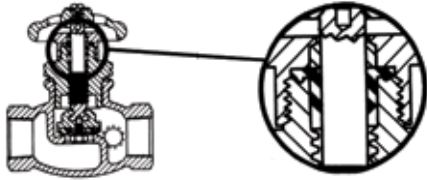

Leak-tight performance is assured and periodic adjustment is not required. The synthetic rubber construction provides smooth operating performance with long service life.

These valves all incorporate a plugged 1/4" NPT side boss on the downstream side of the valve that can be equipped with a hydrostatic relief valve or vent valve.

Please be familiar with the "Installation and Operation Note" and "Downstream Accessory Boss" section of the "V"-ring valve design general information before ordering these valves.

General Features

Rugged quick-acting ACME threads on stem. Threads are under flange ring . . . dust, sand and grit can't reach them.

Swivel seat cannot grind during valve opening or closing.

Synthetic Rubber Seat Disc

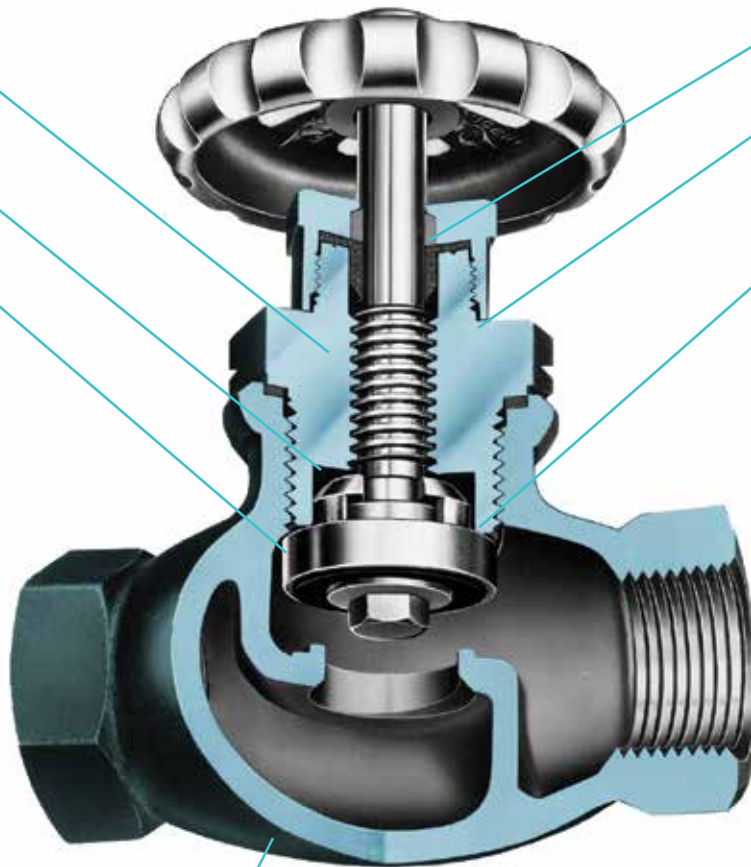

Nylon bearing surrounds stem to prevent galling.

Rubber flange ring stem seal effectively prevents gas escape. The higher the pressure, the tighter the seal.

Metal to metal back seat permits replacement of flange ring with valve in service.

Valve body made of shell molded ductile iron. Highly resistant to cracking or fracturing from wrenching, dropping or hammer blows. Bonnet and seal cap are steel on "A" prefix valves.

Flange Seal Globe and Angle Valves for Bulk Storage Containers, Filling Hoses and Plant Piping 7704, 7705 and 7706 Series

Application

Designed to ensure positive shut-off and long maintenance-free service life in liquid or vapor service. Ideally suited for use on cylinder charging manifolds, truck filling hoses, bulk storage containers and plant piping.

The high quality construction and wide variety of sizes make them highly suited for use with LP-Gas, anhydrous ammonia and in the chemical and petrochemical industries.

Features

- Available with either a brass bonnet and bronze stem for LP-Gas service or a steel bonnet and stainless steel stem for combined LP-Gas and anhydrous ammonia service.
- Flange seal stem provides for leak-proof operation. No packing to retighten or replace.
- Metal-to-metal back seat permits replacement of the flange ring with the valve in service.
- Plugged ¼" NPT boss on downstream side of valve accommodates hydrostatic relief valve or vent valve.
- Swivel seat disc minimizes grinding on the body seat and ensures longer service life.
- "Dropped seat" body design of the angle valve provides high flow capacity.

Materials

Body	Ductile Iron
Bonnet (7704, 05, 06)	Brass
Bonnet (A7704, 05, 06)	Steel
Stem (7704-05-06)	Bronze
Stem (A7704-05-06)	Stainless Steel
Flange Ring	Synthetic Rubber
Seat Disc	Synthetic Rubber



A7704P

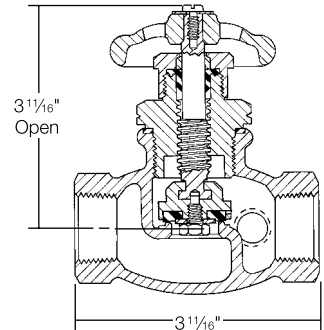

**7704 P
A7704 P
7705 P
A7705 P**



7706P

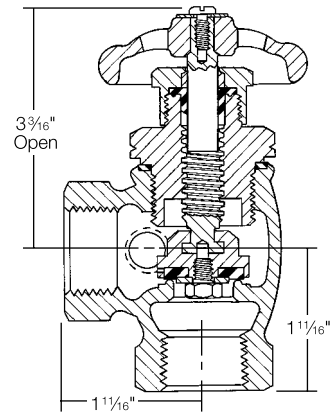

**7704 LP
A7704 LP
7706 P
A7706 P**



Ordering Information

Part Number		Inlet & Outlet Connection (F. NPT)	Flow at 1 PSIG Pressure Drop (Cv) (GPM/Propane)*		Accessories	
Globe	Angle		Globe	Angle	Hydrostatic Relief Valve	Vent Valve
7704P	7704LP	½"	7.3	12.3	SS8001J or SS8001L	TSS3169
A7704P	A7704LP					
7705P	7706P	¾"	11.5	17.7		
A7705P	A7706P					

* To obtain approximate flow at other than 1 PSIG pressure drop, multiply flow in table by square root of pressure drop. Example: A7704LP @ 9 PSIG = 12.3 x √9 = 36.9 GPM/propane. For NH₃ flow, multiply propane flow by .90.

Flange Seal Liquid Transfer Angle Valves for Bulk Storage Containers 7550 and 7551 Series

Application

Designed especially for liquid transfer of LP-Gas from consumer bulk storage containers when used with a Chek-Lok® or equipped with an integral excess flow valve. May also be used for vapor LP-Gas service.

In NH₃ applicator tanks they may be used as a vapor bleeder valve or as a liquid withdrawal valve when installed in a coupling with a dip pipe.

These liquid transfer valves are equipped with an integral excess flow valve for liquid transfer directly from the tank fitting, or without an integral excess flow for LP-Gas transfer through a Check-Lok®.

When equipped with an integral excess flow valve (7550PX), the valve should be mounted in a forged steel 3000 lb. half coupling. When mounted in a 1 1/4" x 3/4" NPT reducing coupling, the 3/4" female thread in this coupling must be full length — equivalent to a forged steel 3000 lb. half coupling.

The excess flow valve will not function properly if these specifications are not met. Refer to the Warning Bulletin in the Excess Flow Valve Section of this catalog.

Features

- Flange seal stem design provides for leak-proof operation. No packing to retighten or replace.
- Large, unrestricted interior ports reduce pressure drop through the valve, increasing capacity and preventing cavitation.
- Resilient swivel seat disc ensures longer seat life and easy, positive shut-off.
- Plugged 1/4" NPT outlet boss accommodates hydrostatic relief valve or vent valve.
- Specifically designed for liquid transfer of LP-Gas with the Chek-Lok®.

Materials

Body (7550, 51).....	Brass
Body (A7550, 51).....	Cadmium Plated Ductile Iron
Bonnet (7550, 51).....	Brass
Bonnet (A7550, 51).....	Steel
Stem (7550, 51).....	Bronze
Stem (A7550, 51).....	Stainless Steel
Flange Ring.....	Synthetic Rubber
Seat Disc.....	Synthetic Rubber



7550P



7550PX

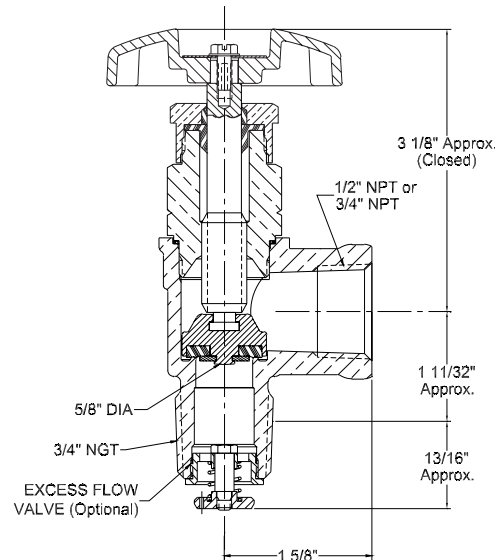

Ordering Information

Part Number	Inlet Connection (M. NPT)	Outlet Connection (F. NPT)	Integral Excess Flow	Flow at 1 PSIG (Cv) Pressure Drop* (GPM/Propane)	Excess Flow Approximate Closing Flow** (GPM/Propane)	Accessories	
						Hydrostatic Relief Valve	Vent Valve
7550P	3/4"	3/4"	No	13.3	-	3127U	3165
A7550P			SS8001J	TSS3169			
7550PX		Yes	-	16.0	3127U	3165	
A7550PX		SS8001J	TSS3169				
7551P	1/2"	1/2"	No	8.9	-	3127U	3165
A7551P			SS8001J	TSS3169			

* To obtain approximate flow at other than 1 PSIG pressure drop, multiply flow in table by square root of pressure drop. Example: 7550P @ 9 PSIG = 13.3 x √9 = 39.9 GPM/propane. For NH₃ flow, multiple propane flow by .90.

** For NH₃ flow, multiply propane flow by .90.

Tank Car Angle Valves for Railroad Tank Cars TA7894P

Application

Designed especially for transfer of LP-Gas and anhydrous ammonia in railroad tank car service.

The combined heavyweight ductile iron castings and precision machining provide ruggedness and superior performance in working pressures up to 400 PSIG.

Features

- "V"-ring spring-loaded pressure seal design provides dependable, leak-free operation. No packing to retighten or replace.
- Wiper o-ring eliminates entrance of dirt and grit into stem area that can prohibit smooth operation.
- Heavy duty ACME stem threads give quick action and are hardened for long service life.
- Swivel seat reduces scoring of seat disc and provides positive shut-off.
- Full diameter seat provides greater flow capacity and low pressure drop.
- Plugged 1/4" NPT boss on downstream side of valve accommodates vent valve or hydrostatic relief valve.
- Equipped with a malleable iron plug and chain installed in the valve outlet.



AAR Approval #E-149515



TA7894P

Materials

Body	Ductile Iron
"V"-Rings	Teflon
O-Ring	Synthetic Rubber
Stem	Stainless Steel
Bonnet	Ductile Iron
Seat Disc	Teflon
Handwheel.....	Cadmium Plated Ductile Iron

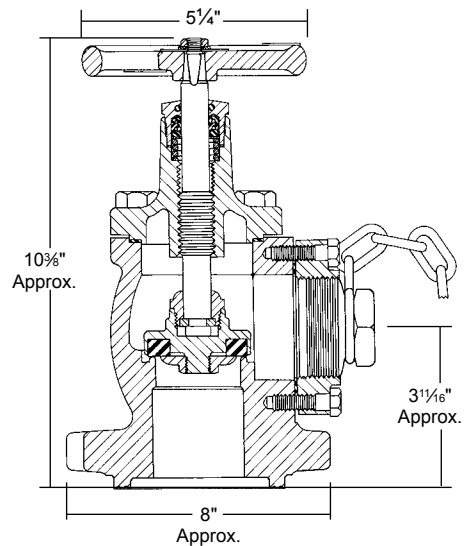

Ordering Information

Part Number	Inlet Connection	Outlet Connection (F.NPT)	Flow At 1 PSIG (Cv) Pressure Drop	Accessories	
				Hydrostatic Relief Valve	Vent Valve
TA7894P	Tank Car Flange	2"	112	SS8001U	TSS3169

* To obtain approximate flow at other than 1 PSIG pressure drop, multiply flow in table by square root of pressure drop. Example: TA7894P @ 9 PSIG = 112 x $\sqrt{9}$ = 336 GPM/propane. For NH₃ flow, multiply propane flow by .90.

High Capacity Liquid Withdrawal Valves For NH3 A8012 Series

Application

The A8012 Series is designed especially for use as a high capacity liquid withdrawal valve on anhydrous ammonia nurse tanks or risers.

This valve incorporates an integral excess flow valve; when the valve is in operation the handwheel must be completely open and back-seated to allow the excess flow valve to function properly as explained in the excess flow section of our L-500 and L-102 catalogs.

Features

- Excess flow valve designed for high flow and low pressure drop.
- Excess flow seat fully contained in the container coupling for maximum protection in the event of external damage to the valve.
- Resilient disc assembly with swivel seat is fully contained for bubble-tight shut-off and long service life.
- "V"- ring spring loaded stem seal design requires no field adjustment.
- ¼" F.NPT port that accommodates a vent valve or hydrostatic relief valve.
- UL Listed for LP-Gas and anhydrous ammonia.

Materials

Body	Ductile Iron
Bonnet	Ductile Iron
Stem	Stainless Steel
Seat Disc	Nitrile
"V" -Rings.....	Teflon
Excess Flow Valve.....	Stainless Steel
Springs	Stainless Steel



A8012D

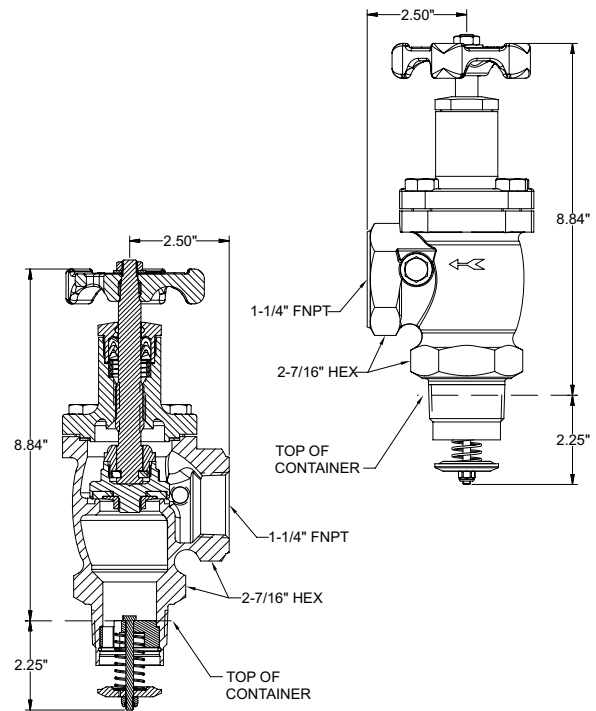

Ordering Information

Part Number	Inlet Connection	Outlet Connection	Approximate Closing Flow GPM	Accessories for NH3 Use	
				Hydrostatic Relief Valve	Vent Valve
A8012D	1½" M.NPT	1¼" F.NPT	72 GPM NH3*	SS8001J	TSS3169
A8012C			45 GPM NH3*		

* When installed in a horizontally flowing system.

Multipurpose Valve for Filling of NH3 Containers A8016DBC

Application

Designed specifically for use as a manual filler valve on anhydrous ammonia applicator tanks. This valve incorporates an integral back check valve.



Features

- Positive seating back check valve opens for maximum flow at minimum pressure drop when filling — regardless of the type of coupling in which the valve is installed.
- Back Check seat is fully contained in the tank coupling for maximum protection in the event of external damage to the valve.
- Resilient seat disc assembly is fully contained on three sides for bubble-tight shut-off and long service life.
- “V”-ring spring-loaded stem seal design requires no repacking or field adjustment.
- Specially machined break-away groove beneath ACME threads will shear-off with excessive pull on the hose and leave the valve body intact.
- Plugged 1/4" NPT boss accommodates vent valve or hydrostatic relief valve.



A8016DBC

Materials

Body	Ductile Iron
Bonnet	Steel
“V”-Rings	Teflon
Stem	Stainless Steel
Seat Disc	Resilient Synthetic Rubber
Back Check Valve.....	Stainless Steel, Steel and Synthetic Rubber
Springs	Stainless Steel

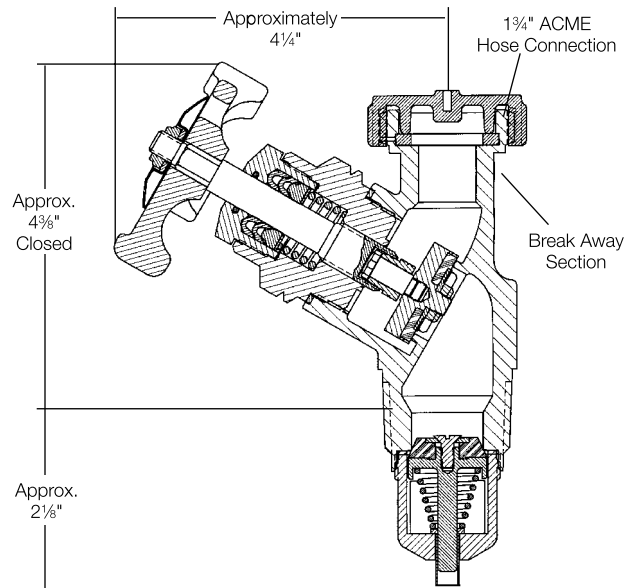

Ordering Information

Part Number	Inlet Connection	Filling Connection	Filling Capacity at 20 PSIG Pressure Drop GPM/NH ₃	Accessories	
				Hydrostatic Relief Valve	Vent Valve
A8016DBC	1 1/4"	1 1/4"	95	SS8001J	TSS3169

Multipurpose Valve for Filling of NH3 Containers A8016DP

Application

Designed specifically for use as a manual valve or vapor equalizing valve on anhydrous ammonia applicator and nurse tanks.

This valve incorporates an integral excess flow valve. When product is required, the valve must be completely open and backseated to allow the excess flow valve to function properly as explained in the excess flow section of this catalog.

Features

- Positive-acting excess flow valve opens for maximum flow at minimum pressure drop when filling -- regardless of the type of coupling in which the valve is installed.
- Excess flow seat is fully contained in the tank coupling for maximum protection in the event of external damage to the valve.
- Resilient seat disc assembly is fully contained on three sides for bubble-tight shut-off and long service life.
- "V"-ring spring-loaded stem seal design requires no repacking or field adjustment.
- Specially machined break-away groove beneath ACME threads will shear-off with excessive pull on the hose and leave the valve body intact.
- Plugged 1/4" NPT boss accommodates vent valve or hydrostatic relief valve.



A8016DP

Materials

Body	Ductile Iron
Bonnet	Steel
"V"-Rings	Teflon
Stem	Stainless Steel
Seat Disc	Resilient Synthetic Rubber
Excess Flow Valve	Stainless Steel--Steel Body
Springs	Stainless Steel

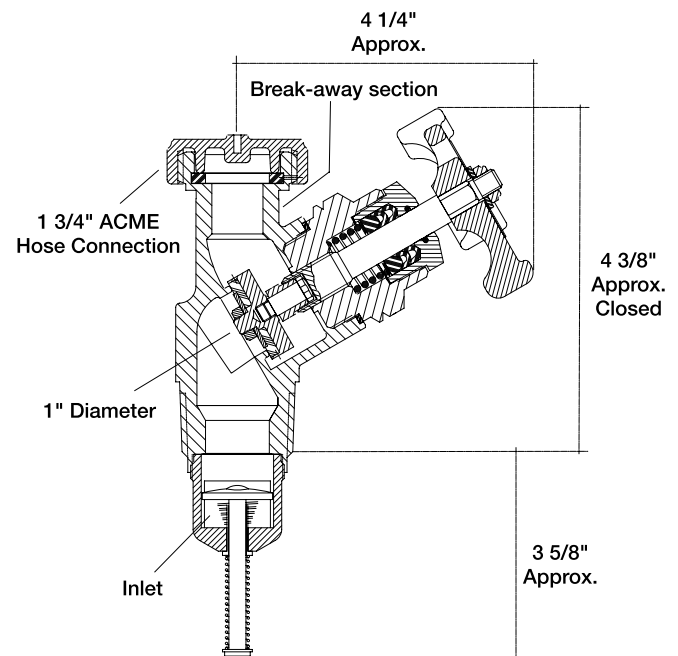

Ordering Information

Part Number	Inlet Connection (M. NPT)	Filling Connection (M. ACME)	Filling Capacity At 20 PSIG Pressure Drop GPM/NH3*	Approximate Excess Flow Closing Flows		Accessories	
				Liquid* GPM/NH3	Vapor** CFH/NH3	Hydrostatic Relief Valve	Vent Valve
A8016DP	1 1/4"	1 3/4"	95	44	24,000	SS8001J	TSS3169

* Determined at 9.5 to 12 PSIG differential.

** Determined at 100 PSIG inlet.

Multipurpose Valves for Liquid Withdrawal of LP-Gas and NH₃ Containers

A8017D & A8020D

Application

Designed especially for use as a high capacity liquid withdrawal valve on LP-Gas and anhydrous ammonia containers.

These valves incorporate an integral excess flow valve. When product is required, the valve must be completely open and backseated to allow the excess flow valve to function properly as explained in the excess flow valve section of this catalog.

The A8017DH is equipped with a soft seated automatic differential back pressure check valve in the seat disc assembly. This allows any pressure build up in the liquid transfer line in excess of 10-15 psig above the container pressure to flow back into the container. The transfer hose is protected against excessive liquid or vapor pressure entrapment, which adds materially to the useful life of flexible hose. In addition to increasing hose service life, the equalizing valve adds substantially to the operating safety of liquid transfer systems.

Features

- Positive-acting excess flow valve opens for maximum flow at minimum pressure drop when filling — regardless of the type of coupling in which the valve is installed.
- Excess flow seat is fully contained in the tank coupling for maximum protection in the event of external damage to the valve.
- Resilient seat disc assembly is fully contained on three sides for bubble-tight shut-off and long service life.
- "V"-ring spring loaded stem seal design requires no repacking or field adjustment.
- A8017DH has two plugged ¼" NPT ports, one on the top and the other on the side, accommodate either a vent valve or hydrostatic relief valve.
- A8020D has a plugged ¼" NPT port that accommodates vent valve, hydrostatic relief valve, or pressure gauge.
- A8017DH incorporates an automatic back check valve built into the shut-off valve, eliminating the need for a separate hydrostatic relief valve.

Materials

Body Ductile Iron
 Bonnet Steel
 Stem Stainless Steel
 Seat Disc Resilient Synthetic Rubber
 "V"-Rings Teflon
 Excess Flow Valve Stainless Steel - Steel Body Springs
 Springs Stainless Steel

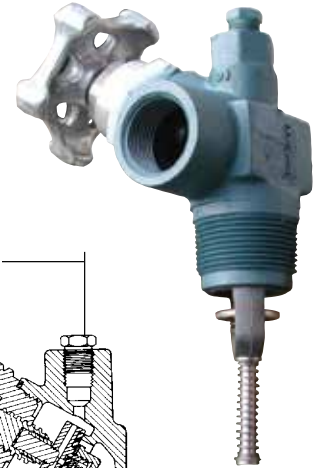

A8017DP

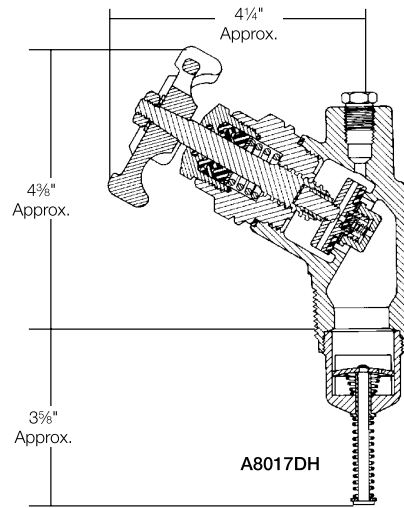

A8017DH

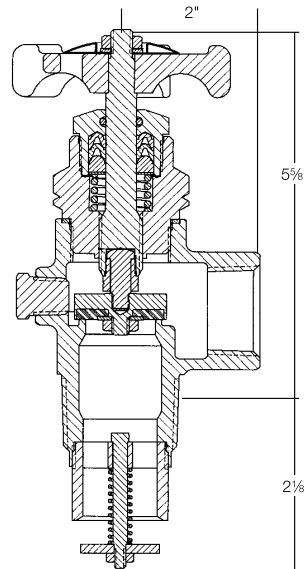

A8020D



Ordering Information

Part Number	Inlet Connection (M. NPT)	Outlet Connection (F. NPT)	Approximate Excess Flow Liquid Closing Flow** (GPM/Propane)	Accessories	
				Hydrostatic Relief Valve	Vent Valve
A8017DH*	1 1/4"	1"	49	Not Required	TSS3169
A8017DP			55		
A8017DLP	1 1/4"	1"	49	SS8001J	TSS3169
A8020D			78	SS8001J	TSS3169

* Built-in back pressure check valve incorporated into shut-off valve.

** * Determined at 11.5 to 13.5 PSIG differential for 3/4" outlet and 9 to 12 PSIG differential for 1" outlet. For NH₃ flow, multiply by .90.

Multipurpose Valve for Filling and Liquid Transfer of NH₃ Containers A8018DP

Application

Designed primarily for use as a combination filler and liquid withdrawal valve on three-opening applicator tanks or on nurse tanks.

This valve incorporates an integral excess flow valve. When product is required, the valve must be completely open and backseated to allow the excess flow valve to function properly as explained in the excess flow valve section of this catalog.

Features

- Functions as both a filler valve and liquid transfer valve, in one unit.
- Positive acting excess flow valve opens for maximum flow at minimum pressure drop when filling — regardless of the type of coupling in which the valve is installed.
- Excess flow seat is fully contained in the tank coupling for maximum protection in the event of external damage to the valve.
- Specially machined break-away groove beneath ACME thread of filler valve will shear-off with excessive pull on the hose and leave the valve body intact.
- Triple guide filler valve check provides for dependable shut-off performance when filling ceases.
- Resilient seat disc assembly is fully contained on three sides for bubble-tight shut-off and long service life.
- "V"-ring spring loaded stem seal design requires no repacking or field adjustment.
- Plugged 1/4" NPT boss accommodates vent valve or hydrostatic relief valve.

Materials

Body	Ductile Iron
Bonnet	Steel
Stem	Stainless Steel
Seat Discs	Synthetic Resilient Rubber
"V"-Rings	Teflon
Excess Flow Valve	Stainless Steel - Steel Body
Springs	Stainless Steel



A8018DP

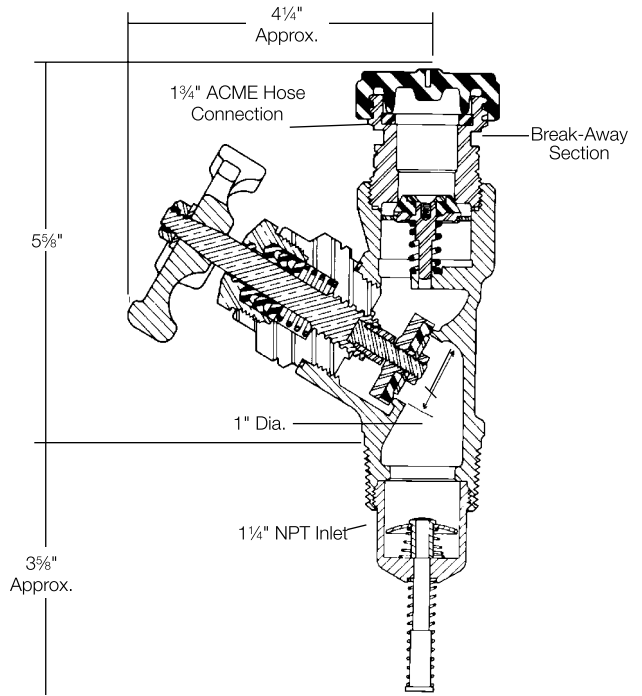

Ordering Information

Part Number	Inlet Connection (M. NPT)	Outlet Connection (F. NPT)	Filling Connection (M.ACME)	Filling Capacity At 20 PSIG Pressure Drop GPM/NH ₃	Approximate Excess Flow Liquid Closing Flow GPM/NH ₃	Accessories	
						Hydrostatic Relief Valve	Vent Valve
A8018DP	1 1/4"	1"	1 1/4"	74	50	SS8001J	TSS3169

* Determined at 9 to 12 PSIG differential.

Multipurpose Filler Valves

8118P and 8117

Application

Designed primarily for use as a Multipurpose valve with combination filler valve and manual shutoff valve for the outlet connection of the valve for use on LP-Gas containers.

This valve incorporates an integral excess flow valve. When product is required, the valve must be completely open and back seated to allow the excess flow valve to function properly as explained in the excess flow valve section of the RegO L-102 or L-500 catalogs.

Features

- Designed as a filler valve for LP-Gas with upper check and manual shutoff.
- Excess flow valve allows for maximum filling rates regardless of the length of the coupling the valve is installed in.
- Excess flow seat is fully contained in the tank coupling for maximum protection in the event of external damage to the valve.
- Breakaway groove protects the ACME in the case of a drive-away with the filler hose still connected.
- V-ring spring loaded stem assembly requires no repacking of field adjustment.
- Plugged ¼" NPT boss allows for a pressure gauge to be installed.
- The one-inch outlet port plugged.



8118P

Materials

Body	Brass
Inlet Connection.....	Brass
Outlet Connection.....	Brass
Spring	Stainless Steel
Seat Disc	Synthetic Rubber
V-rings	Teflon
Excess Flow Valve.....	Stainless Steel

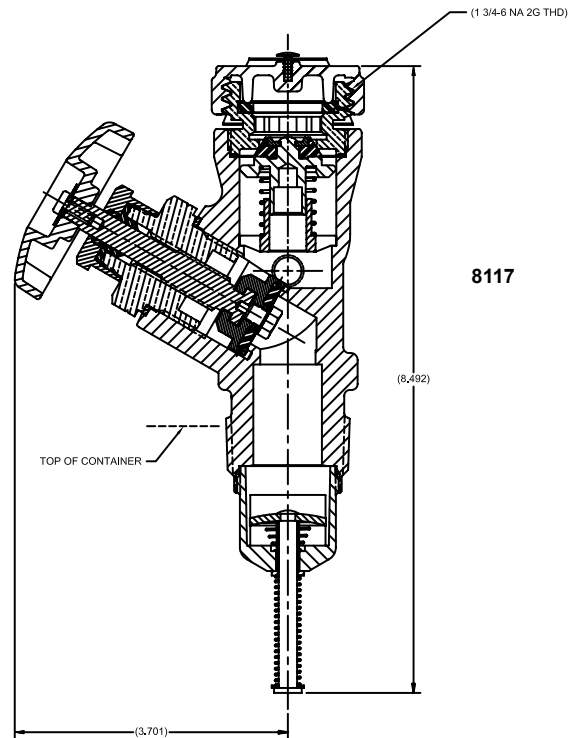

8117



Ordering Information

Part Number	Container Connection	Outlet Connection	Filler Connection	Plug	Filling Capacity at 20 PSIG Pressure Drop
8117	1 ¼" M.NPT	¾" F. NPT	1 ¼" M.ACME	No	82 GPM
8118P		1" F. NPT		Yes	

Adhesive Warning Labels

903-500

The following warning information, Part Number 903-500, is included with each shipment of Quick-Acting and Tank Car Valves to the first purchaser of the product from the factory.

This information is intended to be forwarded throughout the product distribution chain. Additional copies are available from RegO and Authorized Product Distributors.

Part Number	
903-500	Adhesive Warning Label

DANGER	READ THIS FIRST	WARNING
LP-GAS IS EXTREMELY FLAMMABLE AND EXPLOSIVE		
<p>AVOID SERIOUS INJURY AND PROPERTY DAMAGE. IF YOU SEE, SMELL OR HEAR ESCAPING GAS...EVACUATE AREA IMMEDIATELY! CALL YOUR LOCAL FIRE DEPARTMENT! DO NOT ATTEMPT TO REPAIR. DO NOT STORE IN BUILDING OR ENCLOSED AREA. DO NOT USE ON HOT AIR BALLOONS OR AIRCRAFT.</p> <p>Make sure you are thoroughly trained before you attempt any valve installation, maintenance or repair. Improper conditions or procedures can cause accidents resulting in property damage and personal injury.</p> <p>Become thoroughly familiar with NPGA Safety Pamphlet 306 "LP-Gas Regulator and Valve Inspections & Maintenance" and RegO Safety Warnings "LP-Gas Cylinder Valves", "LP-Gas Excess Flow Valves", and "LP-Gas Filler and Hose End Filling Valves" found in the cylinder valve, excess flow valve, and filler valve sections of the L-500 & L-102 Catalogs. Follow their recommendations.</p> <p>Know and understand NFPA Pamphlet 58 "Liquefied Petroleum Gas Code", which is the law in many states. This publication is available from NFPA, Batterymarch Park, Quincy, MA 02269. Following its requirements is essential in the safe use of LP-Gas. Section 4.4 states: "Persons who transfer liquid LP-Gas, who are employed to transport LP-Gas, or whose primary duties fall within the scope of this code shall be trained in proper handling procedures. Refresher training shall be provided at least every three years and shall be documented."</p> <p>Make sure this valve is the proper one for this installation. Avoid misusing LP-Gas equipment.</p> <p>Apply thread joint compound compatible with LP-Gas on valve external threads only. Make sure compound never comes into contact with other parts of the valve.</p> <p>Install valves by applying force to wrenching flats only.</p> <p>Tighten pipe threads approximately 1 to 1½ turns beyond the hand-tight insertion point using a wrench which avoids damage to other valve parts.</p> <p>Check for damage and proper operation after valve installation. Check that the valve is clean and free of foreign material.</p> <p>Check container-valve connection with a non-corrosive leak detection solution before filling with LP-Gas.</p> <p>Purge container before filling with LP-Gas (refer to the RegO LP-Gas Serviceman's Manual for recommended procedure).</p> <p>Test excess flow check valve for proper operation before placing into service. See NPGA Bulletin 113 for recommended procedure.</p> <p>Check outlet connection make-up for leaks with a non-corrosive leak detection solution when placing into service.</p> <p>RegO Filler Valves: To prevent damage to the internal checks when it is necessary to utilize an unloading adapter, use ONLY RegO 3119A, 3120 and 3121 Unloading Adapters with RegO Filler Valves. Carefully follow the instructions supplied with these unloading adapters.</p> <p>If container is not being placed into service at the present time, insert plug or cap onto the outlet connection.</p> <p>In selecting a label for posting at the installation site, consider RegO part number 901-400 or 903-400 along with your own, NPGAs and others.</p> <p>Remember to instruct the owner/user/customer in safety matters concerning LP-Gas and this equipment. See RegO Safety Warnings "LP-Gas Cylinder Valves", "LP-Gas Excess Flow Valves", and "LP-Gas Filler and Hose End Filling Valves" found in the cylinder valve, excess flow valve, and filler valve sections of the L-500 & L-102 Catalogs.</p>		
<p>RegO requests that this information be forwarded to your customers. Additional copies are available from RegO and your authorized RegO Distributor.</p>		
		<p>Printed in USA 09A-0910-0686 Part number 903-500</p>
<p>Elon, N.C. 27244 U.S.A. Phone (336) 449-7707 Fax (336) 449-6594 www.regoproducts.com</p>		

903-500

Section F
Excess Flow, Check, Filler
and Vapor Equalizing Valves

F

Limited 10 Year Warranty and Limitation Of Liability

LIMITED 10 YEAR WARRANTY

RegO warrants to the original purchasers the products and repair kits manufactured by it to be free from defects in materials and workmanship under normal use and service for a period of 10 years from the date of manufacture. If within thirty days after buyer's discovery of what buyer believes is a defect, buyer notifies in writing and ships the product to RegO at 100 RegO Drive, Elon, NC 27244, RegO, at its option, and within forty-five days of receipt, will repair, replace F.O.B. point of manufacture, or refund the purchase price of that part or product found by RegO to be defective. Failure of buyer to give such written notice and ship the product within thirty days shall be deemed an absolute and unconditional waiver of any and all claims of buyer arising out of such defect.

This warranty does not extend to any product or part that is not installed and used after installation in accordance with RegO's printed instructions, all applicable state and local regulations, and all applicable national standards, such as those promulgated by NFPA, DOT and ANSI. This warranty does not extend to any product or part that has been damaged by accident, misuse, abuse, failure to maintain, or neglect, nor does it extend to any product or part which has been modified, altered, disassembled, or repaired in the field. This warranty does not cover any cosmetic issues, such as scratches, dents, marring, fading of colors or discoloration.

Except as expressly set forth above, and subject to the limitation of liability below, RegO MAKES NO OTHER WARRANTY, EXPRESS OR IMPLIED, INCLUDING, BUT NOT LIMITED TO, THE IMPLIED WARRANTIES OF MERCHANTABILITY AND FITNESS FOR A PARTICULAR PURPOSE, with respect to its products and parts, whether used alone or in combination with others. RegO disclaims all warranties not stated herein.

LIMITATION OF LIABILITY

RegO's total liability for any and all losses and damages arising out of any cause whatsoever shall in no event exceed the purchase price of the products or parts in respect of which such cause arises, whether such cause be based on theories of contract, negligence, strict liability, tort or otherwise.

RegO shall not be liable for incidental, consequential or punitive damages or other losses. RegO shall not be liable for, and buyer assumes any liability for, all personal injury and property damage connected with the handling, transportation, possession, further manufacture, other use or resale of products, whether used alone or in combination with any other products or materials.

From time to time buyers might call to ask RegO for technical advice based upon limited facts disclosed to RegO. If RegO furnishes technical advice to buyer, whether or not at buyer's request, with respect to application, further manufacture or other use of the products and parts, RegO shall not be liable for such technical advice or any such advice provided to buyer by any third party and buyer assumes all risks of such advice and the results thereof.

NOTE: Some states do not allow the exclusion or limitation of incidental, consequential or punitive damages, so the above limitation or exclusion may not apply to you. The warranty gives you specific legal rights, and you may have other rights that vary from State to State. The portions of this limited warranty and limitation of liability shall be considered severable and all portions which are not disallowed by applicable law shall remain in full force and effect.

WARNING

All RegO products are mechanical devices that will eventually become inoperative due to wear, corrosion and aging of components made of material such as rubber, etc. The environment and conditions of use will determine the safe service life of these products. Periodic inspection and maintenance are essential to avoid serious injury and property damage.

Many RegO products are manufactured components which are incorporated by others on or in other products or systems used for storage, transport, transfer and otherwise for use of toxic, flammable and dangerous liquids and gases. Such substances must be handled by experienced and trained personnel only, using accepted governmental and industrial safety procedures.

NOTICE TO USERS OF PRODUCTS

The Limited Warranty stated above is a factory warranty to the first purchasers of RegO products. Since most users have purchased these products from RegO distributors, the user must within thirty (30) days after the user's discovery of what user believes is a defect, notify in writing and return the product to the distributor from whom he purchased the product/part. The distributor may or may not at the distributor's option choose to submit the product/parts to RegO, pursuant to this Limited Warranty. Failure by buyer to give such written notice within thirty (30) days shall be deemed an absolute and unconditional waiver of buyer's claim for such defects. Acceptance of any alleged defective product/parts by RegO's distributor for replacement or repairs under the terms of RegO's Limited Warranty in no way determines RegO's obligations under this Limited Warranty.

Because of a policy of continuous product improvement, RegO reserves the right to change designs, materials or specifications without notice.

Foreword

This catalog describes a complete line of equipment available from RegO® for use with Liquid Propane (LP)-Gas and anhydrous ammonia (NH₃). The following points are important to know for proper use of the catalog:

1. Illustrations and drawings of individual products are representative of “product groups” and all products within a product group are similar in construction.
2. Materials used for construction of products in this catalog are suitable for rated service pressure at temperatures of -40°F to +165°F, unless otherwise specified.
3. Products in this catalog are only intended for use in LP-Gas and/or anhydrous ammonia service as follows.
 - a. “A” or “AA” prefix — Products with this prefix are suitable for NH₃ service (i.e., contain no brass parts).
 - b. “AA” prefix on relief valves — These valves are NOT suitable for use with LP-Gas service. These are of partial aluminum materials and are listed by Underwriters Laboratories (UL) for NH₃ service only.
 - c. All other products including “A” prefix are suitable for use with LP-Gas & NH₃ service.
 - d. “SS” prefix—Hydrostatic relief valve with this prefix are suitable for NH₃ and LP-Gas service (i.e., they have stainless steel materials).
4. We manufacture valves and adapters designed to be used on LP-Gas and Anhydrous Ammonia systems, we do not design systems or consult in system design. For this type of information consult a professional Engineer.

Caution

Do not use any product contained in this catalog with any service commodity other than LP-Gas or NH₃. If you have a need for use of another application, contact RegO, 100 RegO Drive, Elon, NC 27244, (336) 449-7707 ecii@regoproducts.com before proceeding.

Proper application, installation and maintenance of products in this catalog are essential. Users of these products should obtain further information if there are any doubts or questions.

Warning

All RegO products are mechanical devices that will eventually become inoperative due to wear, corrosion and aging of components made of materials such as rubber. The environment and conditions of use will determine the safe service life of these products. Periodic inspection and maintenance are essential to avoid serious injury and property damage.

Many RegO products are manufactured for storage, transport, transfer and use of toxic flammable and dangerous liquids and gases. Such substances should be handled by experienced and trained personnel only, using accepted governmental and industrial safety procedures. Never vent LP-Gas near any possible source of ignition.

Notice

Installation, usage, and maintenance of all RegO products must be in compliance with all RegO instructions as well as requirements and provisions of NFPA #54, NFPA#58, DOT, ANSI, and all applicable federal, state, provincial and local standards, codes, regulations, and laws.

Inspection and maintenance on a periodic basis is essential. Installation and maintenance should be performed only by qualified personnel.

Be sure all instructions are read and understood before installation, operation and service.

Filters

RegO LP-Gas equipment is designed to operate in a system free from contamination. A variety of in-line filters are commercially available to the LP-Gas industry for installation in domestic systems.

The use of an in-line filter should be considered when other system components may be unclean and the system contaminated by rust, scale, dirt, debris or other foreign material.

Safety Warnings



Purpose

In its continuing quest for safety, RegO publishes a series of bulletins explaining the hazards associated with the use, misuse, and aging of LP-Gas valves and regulators. It is hoped that these factual bulletins will make clear to LP-Gas dealer managers and service personnel, that the utmost care and attention must be used in the installation, inspection, and maintenance of these products, or problems could occur which would result in injuries and property damage.

The National Fire Protection Association NFPA 58 Liquefied Petroleum Gas Code - 2017 Edition states in Section 4.4 Qualification of Personnel; "Persons whose duties fall within the scope of this code shall be provided with training that is consistent with the scope of their job activities and that includes proper handling and emergency response procedures... Refresher training shall be provided at least every 3 years, initial and subsequent training shall be documented". These "RegO Safety Warnings" may be useful in training new employees and reminding older employees of hazards that can occur. It is recommended that all employees complete the Propane Education Research Council's Certified Employee Training Program.

Nature of Warnings

It is recognized that warnings should be as brief as possible, but the factors involved in excess flow valve failures to perform are not simple. They need to be fully understood. If there is a simple warning, it would be:

Make sure that the excess flow valve really closes when the flow exceeds normal transfer flow.

This bulletin is not intended to be an exhaustive treatment of excess flow valves, and certainly does not cover all safety practices that should be followed in installation, operation and maintenance of LP-Gas systems which include excess flow valves.

Selection and Installation

The selection of a given closing rating of an excess flow valve involves an analysis of the complete piping system and is beyond the scope of this bulletin.

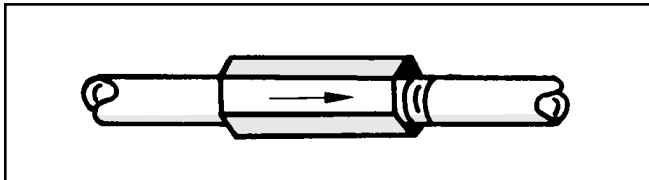

It is sufficient to say that an excess flow valve must be installed in the correct direction and will close only if the flow of liquid or vapor exceeds its designed closing rating. Many valves have been installed with closing ratings considerably higher than any flow that could be obtained by a downstream rupture in piping or hoses and thus give none of the protection for which they are intended.

RegO provides excess flow valves with a number of closing ratings. RegO obviously can take no responsibility for the proper selection or correct installation of any valve.

Excess flow valves do not provide complete shut-off because there is a bleed at the check to permit pressure equalization.

Causes of Failure to Close

Installers, LP-Gas plant managers and service personnel should be aware that the excess flow valves may not close if these conditions are present.

1. The piping system restrictions (due to pipe length, branches, reduction in pipe size or number of other valves) decrease the flow rate to less than the valve's closing flow.

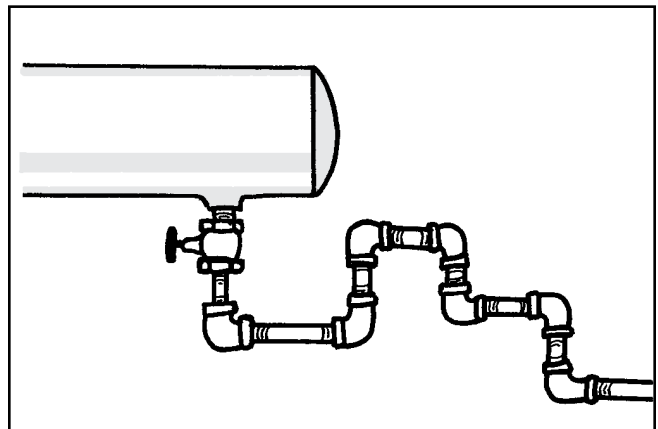

LP-Gas Excess Flow Valves

2. The break or damage to the downstream line is not large enough to allow enough flow to close the valve.

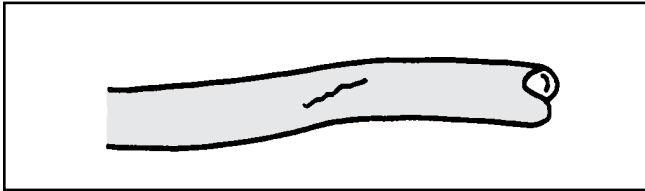

3. A shut-off valve in the line is only partially open and will not allow enough flow to close the excess flow valve.

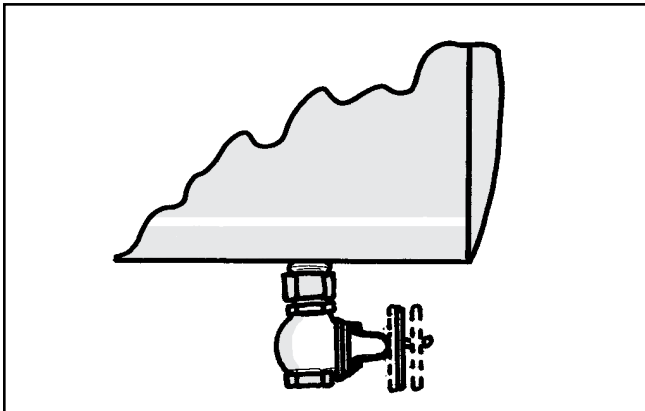

4. LP-Gas pressure upstream of the excess flow valve, particularly due to low temperature, is not high enough to produce a closing flow rate.

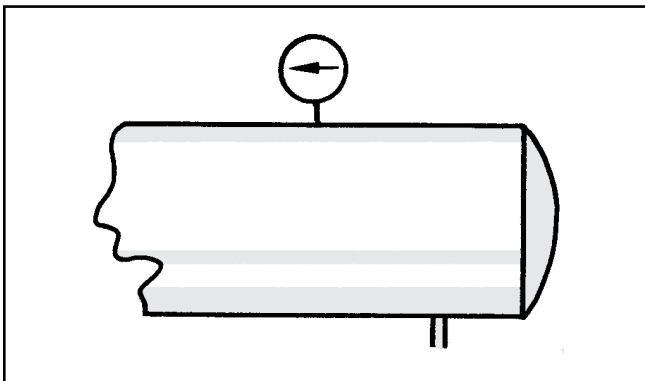

5. Foreign matter (such as welding slag, scale or sludge) is lodged in the valve and prevents closing.

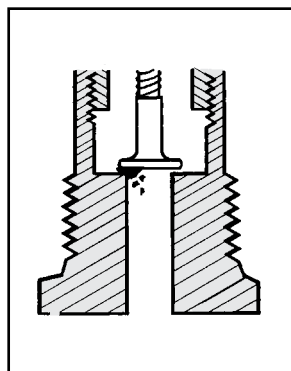

Because of these limitations, it is good industry practice to NOT rely entirely on excess flow valves for protection. Installation of emergency shut-off valves with remote controls is recommended in addition to excess flow valves.

Testing

The National Propane Gas Association Safety Bulletin #113-78 states:

"In order to test an excess flow valve in a piping system, the flow through the valve must be made to exceed the valve's closing rating. This testing should only be attempted by trained personnel familiar with the process. If no one at the facility has experience in proper testing, outside expert help should be obtained. The exact procedure used may vary with the installation, advisability of gas discharge and availability of equipment.

In general, most testing makes use of the fact that excess flow valves are "surge sensitive" and will close quicker under a sudden flow surge than under steady flow. A sufficient surge can often be created by using a quick open/close valve to control sudden, momentary flow into a tank or piping section containing very low pressure. An audible click from the excess flow valve (and corresponding stoppage of flow) indicates its closure.

A test involving venting gas to the atmosphere is hazardous and may be impractical, or illegal.

Any test of any excess flow valve will not prove that the valve will close in an emergency situation, due to reasons cited before. This test will only check the valve's condition, and the flow rate sizing for those test conditions."

General Warning

All RegO products are mechanical devices that will eventually become inoperative due to wear, contaminants, corrosion and aging of components made of materials such as metal and rubber.

The environment and conditions of use will determine the safe service life of these products. Periodic testing at least once a year when tank pressures are low and maintenance, as required, are essential.

Because RegO products have a long and proven record of quality and service, LP-Gas dealers may forget the hazards that can occur because an excess flow valve is used beyond its safe service life. Life of an excess flow valve is determined by the environment in which it "lives". The LP-Gas dealer knows better than anyone what this environment is.

NOTE: There is a developing trend in state legislation and in proposed national legislation to make the owners of products responsible for replacing products before they reach the end of their safe useful life. LP-Gas dealers should be aware of legislation which could effect them.

Troubleshooting Excess Flow Valve Installations

Periodical Inspections for Excess Flow Valves

Excess flow valves should be tested and proven at the time of installation and at periodic intervals not to exceed one year. CAUTION: Testing an excess flow valve in the summer when tank pressures are high will not prove that the same valve will also function under low pressure conditions in the winter. Once a year testing should be conducted during the winter.

The test should include a simulated break in the line by the quick opening of a shut-off valve at the farthest point in the piping that the excess flow valve is intended to protect. If the excess flow valve closes under these conditions, it is reasonable to assume that it will close in the event of accidental breakage (clean break) of the piping at any point closer to the excess flow valve.

The National Propane Gas Association Safety Bulletin Number 113-78 states:

In order to test an excess flow valve in a piping system, the flow through the valve must be made to exceed the valve's closing rating. This testing should only be attempted by trained personnel familiar with the process. If no one at the facility has experience in proper testing, outside expert help should be obtained. The exact procedure used may vary with the installation, advisability of gas discharge and availability of equipment.

In general, most testing makes use of the fact that excess flow valves are "surge sensitive" and will close quicker under sudden flow surge than under steady flow. A sufficient surge can often be created by using a quick open/close valve to control sudden, momentary flow into a tank or piping section containing very low pressure. An audible click from the excess flow valve (and corresponding stoppage of flow) indicates its closure.

A test involving venting gas to the atmosphere is hazardous and may be impractical or illegal.

Any test of any excess flow valve will not prove that the valve will close in an emergency situation, due to reasons cited before. This test will only check the valve's condition and the flow rate sizing for those test conditions.

What prevents excess flow valves from closing when the line breaks?

For one or a combination of the following reasons, excess flow valves have been prevented from closing in emergencies:

1. Not a Clean Break

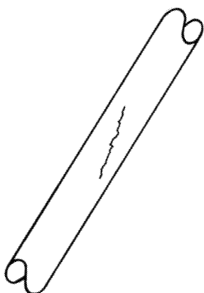

Hoses with a split or tear, and pipe lines not completely severed may be emitting LP-Gas in an amount insufficient to cause an "excess" flow. The amount of LP-Gas which can escape through such breaks may be even less than the flow during normal transfer service and under these conditions the excess flow valve could not be expected to close.

2. Line Restriction Too Great

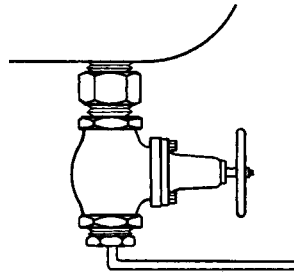

An excess flow valve installed in a tank outlet will not close if the line beyond it is reduced or if the flow is otherwise restricted by too many fittings or too long a run because the line is incapable of passing the amount of LP-Gas necessary to create an "excess" flow. This condition should be corrected when testing a system by simulating a break at the farthest possible point and replacing any restrictive hose, pipe or fittings.

3. Improper Operating Practice

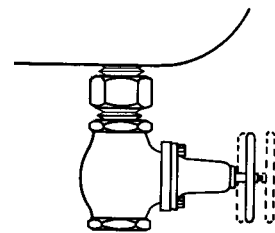

A restriction can also be imposed upon the excess flow valve by an improperly opened valve at the tank outlet. The shut-off valve should be either fully opened or fully closed. If "throttled," the valve could reduce the amount of LP-Gas passing through the excess flow valve in a sufficient amount to keep it from closing. Throttling operations should not be performed in the lines being protected by excess flow valves.

4. Improper Selection

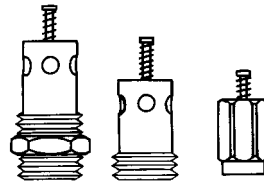

The many types of excess flow valves available are designed for specific jobs. The excess flow valve selected should remain open during normal flow but close at "excess" flow. An inspection which simulates a line break prior to start-up operations will determine if the proper valve has been selected.

5. Tampering with Excess Flow Valves

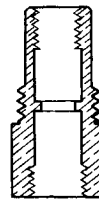

Sometimes an operator, annoyed with frequent closures of an excess flow valve with too low a rating, has mutilated the valve and forgotten to replace it with a properly rated excess flow valve. A pre-test of the system would reveal this and allow the excess flow valve to be replaced.

6. Impurities in the Line

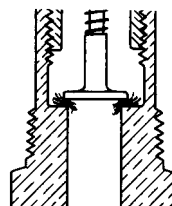

Dirt, weld slag, broken drill taps, and various other foreign objects have been found jammed between the valve disc and valve seat to prevent excess flow valves from closing. A pre-test of the system would also discover this.

The Limitations of Excess Check Valves for LP-Gas

Excess flow check valves have been of help in limiting gas loss in many incidents involving breakage of hoses and transfer piping. Thus, they do provide a useful safety function in LP-Gas systems. However, there have also been transfer system accidents where excess flow valves have been ineffective in controlling gas loss due to a variety of conditions and to the inherent limitations of these valves. This bulletin explains what protection excess flow valves can offer, points out conditions which can interfere with that protection, and offers suggestions for effective excess flow valve installation.

An excess flow valve is a protective device to help control the discharge of product in the event of complete breakage of pipe lines or hose rupture. However, an excess flow valve can only offer limited protection from gas discharge, because it will only close under those conditions which cause the flow through the valve to exceed its rated closing flow, and even when closed it necessarily allows some "bleed" past the valve.

An excess flow valve is not designed to close and thus may not provide protection, if any of the following conditions are present:

1. The piping system restrictions (due to pipe length, branches, reduction in pipe size, or number of other valves) decrease the flow rate to less than the valve's closing flow. (Valve should be selected by closing flow rating — not just by pipe size).
2. The break or damage to the downstream line is not large enough to allow enough flow to close the valve.
3. A shut-off valve in the line is only partially open and will not allow enough flow to close the excess flow valve.
4. LP-Gas pressure upstream of the excess flow valve, particularly due to low temperature, is not high enough to produce a closing flow rate.
5. Foreign matter (such as welding slag) is lodged in the valve and prevents its closing.
6. A buildup of process material (sludge), which may be found in LP-Gas, may occur over a period of time and cause the valve to stick open.
7. The piping break or damage occurs upstream of an in-line excess flow valve, so the escaping product is not passing through the valve.
8. The flow through the valve is in the wrong direction. (Excess flow valves only respond to flow in one direction.)
9. The excess flow valve has been damaged, or is otherwise not in operating condition.

Because of these limitations of excess flow valves, they should not be relied upon as the only means of controlling the escape of product in the event of piping damage. When possible, shut-off protection by quick closing valves, with shut-off controls accessible in spite of likely line damage, should be provided in addition to, or instead of excess flow valves.

Where excess flow valves are installed, they should be checked to see that:

1. They are installed in the correct direction — the arrow on the valve indicates the shut-off direction.
2. The flow rating on the valve is proper for the installation. The rating must be above the normal system flow, but not higher than necessary to prevent "nuisance" closing in normal conditions. If the manufacturer's catalog information is not sufficient, the valve suppliers can provide sizing assistance.
3. In-line excess flow valves are installed so likely piping damage will occur downstream of the valve and will not separate the valve from the upstream piping.

When the excess flow valves can be examined separate from the line (before the installation or if removed for system maintenance), they should be checked to see that the parts are in good condition and that the poppet can be pushed fully closed.

Testing of Excess Flow Valves

In order to test an excess flow valve in a piping system, the flow through the valve must be made to exceed the valve's closing rating.

This testing should only be attempted by trained personnel familiar with the process. If no one at the facility has experience in proper testing, outside expert help should be obtained. The exact procedure used may vary with the installation, advisability of gas discharge, and availability of equipment.

In general, most testing makes use of the fact that excess flow valves are "surge sensitive" and will close quicker under a sudden flow surge than under steady flow. A sufficient surge can often be created by using a quick-closing valve to control sudden, momentary flow into a tank or piping section containing very low pressure. An audible click from the excess flow valve (and corresponding stoppage of flow) indicates its closure.

A test involving venting gas to the atmosphere is hazardous and may be impractical, or illegal.

Any test of any excess flow valve will not prove that the valve will close in an emergency situation, due to reasons cited before. This test will only check the valve's condition, and the flow rate sizing for those test conditions.

For additional information on excess flow valves and other means of shut-off protection, contact RegO and refer to NFPA 58.

Prepared by
NATIONAL PROPANE GAS ASSOCIATION

The purpose of this bulletin is to set forth general safety practices for the installation, operation, and maintenance of LP-Gas equipment. It is not intended to be an exhaustive treatment of the subject, and should not be interpreted as precluding other procedures which would enhance safe LP-Gas operations. The National Propane Gas Association assumes no liability for reliance on the contents of this bulletin.

General Information

RegO Excess Flow Valves have been designed, developed, and manufactured for a wide variety of industry needs for more than three decades.

Throughout the years, those concerned with installing and operating bulk plant facilities have looked to RegO products with confidence for reliable, long-lasting valves as required by the National Fire Protection Association (NFPA) Standards 58 and 59, as well as any state, provincial, and local regulations.

It is a responsibility we have not taken lightly. RegO products continue to not only assess the most effective designs, but anticipate and meet the industry's changing requirements. Toward that goal, RegO products include over fifty different types and sizes of excess flow valves (most of which are listed by Underwriters Laboratories) to meet the needs of the LP-Gas and anhydrous ammonia industries.

An Explanation and Warning

An excess flow valve is a spring-loaded check valve which will close only when the flow of fluid through the valve generates sufficient force to overcome the power of the spring holding it open. Each valve has a closing rating in gallons per minute and CFH/air.

The selection of a proper closing rating is critical. It requires a technical understanding of the flow characteristics of the piping system, including restrictions of the piping and other valves and fittings downstream of the excess flow valve.

System designers and operating people must understand why an excess flow valve, which remains open in normal operations, may fail to close when an accident occurs.

Warning: A downstream break in piping or hoses may not result in sufficient flow to close the valve.

How They Work

Excess flow valves permit the flow of liquid or vapor in either direction. This flow is controlled in only one direction (the direction of the arrow stamped on the valve). If the flow in that direction exceeds a predetermined rate (shown in this catalog for each valve), the valve automatically closes.

The valve disc is held in the open position by a spring. When the flow creates a pressure drop across the valve disc that overcomes the preset load on the spring, the valve disc moves to the closed position. It remains closed until the force on both sides of the valve disc are approximately equal (a small bleed hole in the disc of each valve permits equalization), then the spring automatically reopens the valve. When a line is completely broken, the pressure cannot equalize and the excess flow valve remains closed until the line is repaired. Because the bleed hole in each valve disc permits equalization of pressure, excess flow valves do not provide a 100 percent shut-off.

Proper Installation

Since excess flow valves depend on flow in order to close, the line downstream of the excess flow valve should be large enough not to excessively restrict the flow. If the piping is too small, unusually long or restricted by too many elbows, tees and other fittings, consideration should be given to the use of larger size pipe fittings.

An excess flow valve in a pump suction line cannot be expected to close in the case of a clean break in the line beyond the pump, as the pump constitutes too great a restriction, even if running.

Good piping practices dictate the selection of an excess flow valve with a rated closing flow of approximately 50 percent greater than the anticipated normal flow. This is important because valves which have a rated closing flow very close to the normal flow may chatter or slug closed when surges in the line occur during normal operation, or due to the rapid opening of a control valve.

All installations must be in accordance with NFPA Standards 58 and 59, as well as state, provincial and local regulations.

Cotter pin prevents loss of spring retainer due to vibration in service.

Spring retainer.

Stainless steel spring for consistent closing flow, long service life.

Welded for strength.

Precision machining.

Generous flow channels for lowest pressure drop are particularly important in pump suction lines.

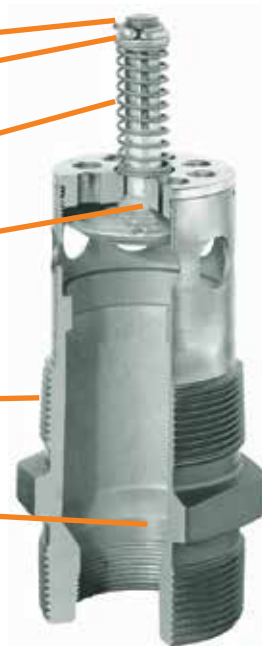

Excess Flow Valves for Liquid or Vapor Service

1519C Series

Application

Designed for top mounting in storage tank manhole covers for liquid or vapor applications. The tapped inlet allows for an optional 1" NPT dip pipe connection to withdraw liquid from the top of the tank.

The 1519C4 is designed for installation in long line or branch piping applications.

Features

- Precision machined
- Generous flow channels provide low pressure drop.
- Cotter pin prevents loss of spring retainer due to vibration in service.
- Stainless steel spring provides consistent closing flow and long service life.

Materials

1519C2

Body Brass
 Valve Poppet w/Stem Brass
 Spring Stainless Steel
 Guide Brass

1519C4

Body Brass
 Valve Disc Cadmium Plated Steel
 Stem Stainless Steel
 Spring Stainless Steel
 Guide Ductile Iron

Performance

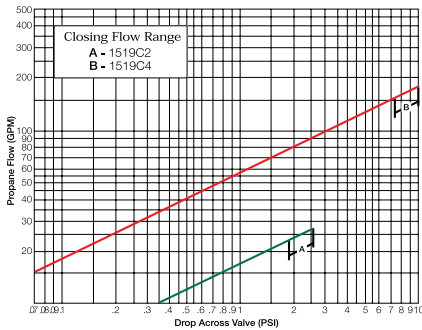

NOTE: Multiply flow rate by .94 to determine liquid butane flow.



1519C2



1519C4

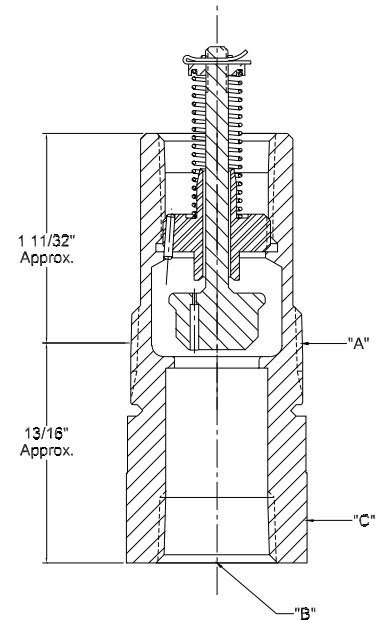

Typical Installation

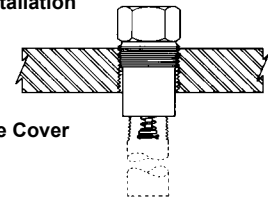

Manhole Cover

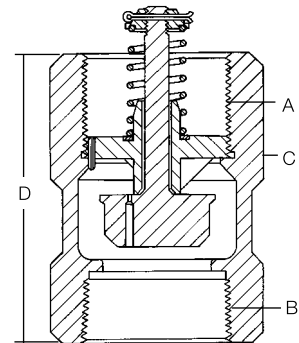

1519C4

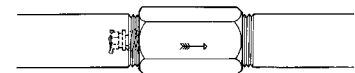

Typical Installation

Ordering Information

Part Number	A Inlet Connection NPT	B Outlet Connection F.NPT	C Wrench Hex Flats	D Effective Length (Approx.)	E Threaded End to Port	Approximate Closing Flows**		
						Liquid (GPM Propane)	Vapor SCFH (Propane)	
							25 PSIG Inlet	100 PSIG Inlet
1519C2	1 1/2" Male*	1"	2 1/4"	2 1/16"	2 11/16"	25	5,000	8,800
1519C4	2" Female	2"	3"	4 9/16"	-	170	28,590	48,600

* 1" Female Dip Pipe Connection

** Based on horizontal installation of excess flow valve. Flows are slightly more when valves are installed with outlet up; slightly less when installed with outlet down.
 NOTE: Multiply flow rate by .94 to determine liquid butane flow.

Excess Flow Valves for Liquid or Vapor Line Service

1519A Series, 1519B Series and A1519 Series

Application

Designed for top installation, in any position, in liquid or vapor service lines. They are intended for long lines or branch piping where tank mounted excess flow valves cannot suffice.

Features

- Precision machined.
- Generous flow channels provide low pressure drop.
- Cotter pin prevents loss of spring retainer due to vibration in service.
- Stainless steel spring provides consistent closing flow and long service life.

Materials

1519A Series and 1519B Series

Body Brass
 Valve Poppet w/Stem Brass
 Spring Stainless Steel
 Guide Brass

A1519 Series

Body Cadmium Plated Steel
 Valve Disc Cadmium Plated Steel
 Stem Stainless Steel
 Spring Stainless Steel
 Guide Ductile Iron

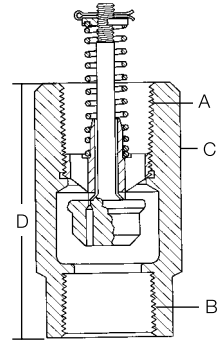

1519A2, 1519A3, 1519A4, 1519B4, A1519A2, A1519A4, A1519B4

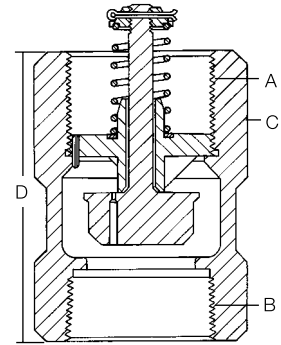

A1519A6

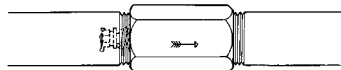

Typical Installation



Performance

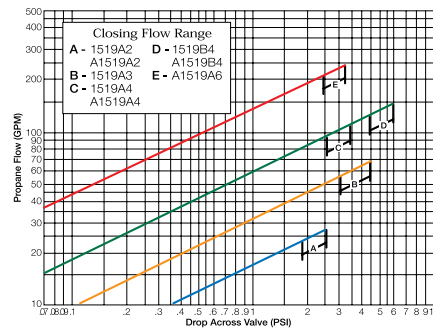

NOTE: Multiply flow rate by .94 to determine liquid butane flow and by .90 to determine liquid anhydrous ammonia flow.

Ordering Information

Part Number	Brass or Steel	A Inlet Connection NPT	B Outlet Connection F NPT	C Wrench Hex Flats	D Effective Length (Approx)	Approximate Closing Flows*		
						Liquid (GPM Propane)	Vapor SCFH (Propane)	
							25 PSIG Inlet	100 PSIG Inlet
1519A2	Brass	1"	1"	1 3/4"	3 1/2"	25	5,000	8,800
A1519A2	Steel							
1519A3	Brass	1 1/2"	1 1/2"	2 1/4"	4"	60	11,500	20,200
1519A4								
A1519A4	Steel	2"	2"	3"	4 9/16"	100	19,000	34,500
1519B4	Brass				4 13/16"			
A1519B4	Steel				4 9/16"			
A1519A6					4 13/16"			
		3"	3"	4"	6 27/32"	225	45,000	82,000

* Based on horizontal installation of excess flow valve. Flows are slightly more when valves are installed with outlet up; slightly less when installed with outlet down.

NOTE: Multiply flow rate by .94 to determine liquid butane flow and by .90 to determine liquid anhydrous ammonia flow.

Excess Flow Valves for Liquid or Vapor 3272 Series, 3282 Series, 3292 Series, A3272 Series, A3282 Series, A3292 Series, 7574 and 12472

Application

Designed for liquid or vapor use for filling, withdrawal and vapor equalizing in container or line applications. They are intended for long lines or branch piping where tank-mounted excess flow valves are inadequate.

Features

- Precision machined.
- Generous flow channels provide low pressure drop.
- Stainless steel spring provides consistent closing flow and long service life.

Materials

Series 3272, 3282, 3292, 7574, 12472

Body	Brass
Seat Disc	Brass
Stem	Brass
Spring	Stainless Steel
Guide (12472 ONLY).....	Plastic

Series A3272, A3282, A3292

Body	Cadmium Plated Steel
Seat Disc	Cadmium Plated Steel
Stem	Cadmium Plated Steel
Spring	Stainless Steel



3282A

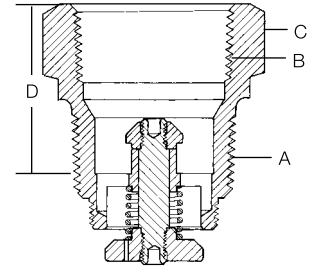

Typical Installation

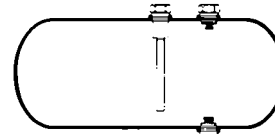

Container Service

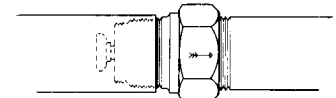

Pipe Line Service

Performance

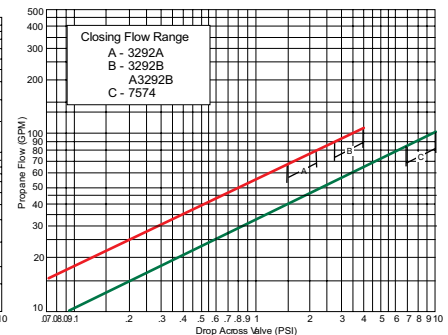
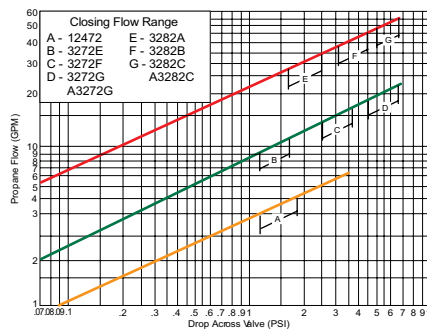

Ordering Information

NOTE: Multiply flow rate by .94 to determine liquid butane flow and by .90 to determine liquid anhydrous ammonia flow.

Part Number	Brass or Steel	A Inlet Connection (M. NPT)	B Outlet Connection (F. NPT)	C Wrench Hex Flats	D Effective Length (Approx.)	Approximate Closing Flow*			
						Liquid (GPM Propane)	Vapor SCFH (Propane)		
							25 PSIG Inlet	100 PSIG Inlet	
12472	Brass	3/4"	3/4"	1 1/8"	1 7/16"	4	1,050	1,700	
3272E					10	2,100	3,700		
3272F					15	2,800	5,000		
3272G					20	3,700	6,900		
A3272G	Steel				1 3/8"				
3282A	Brass	1 1/4"	1 1/4"	2"	1 7/16"	30	5,850	10,000	
3282B					40	7,600	13,600		
3282C					50	9,000	16,300		
A3282C	Steel				1 5/8"				
7574	Brass	1 1/2"	1 1/2"	2 1/4"	1 1/8"	90	15,200	28,100	
7574L					70	14,000	25,000		
3292A	Steel				2 7/8"	75	14,200	24,800	
A3292A					3"				
3292B	Brass	2"	2"	2 1/2"	2"	100	18,100	32,700	
A3292B	Steel								3"
A3292C									

* Based on horizontal installation of excess flow valve. Flows are slightly more when valves are installed with outlet up; slightly less when installed with outlet down.

Excess Flow Valve for Autogas Dispensing Systems 3272H

Application

Especially designed for high flow/high differential dispensing systems. Can also be used for filling, liquid withdrawal, and vapor equalizing in container or line applications.



Features

- Solid brass construction
- Stainless steel spring
- Meets UL requirements
- Highest flowing valve in the market

Materials

Body Brass
 Spring Stainless Steel
 Seat Brass



3272H

Typical Installation

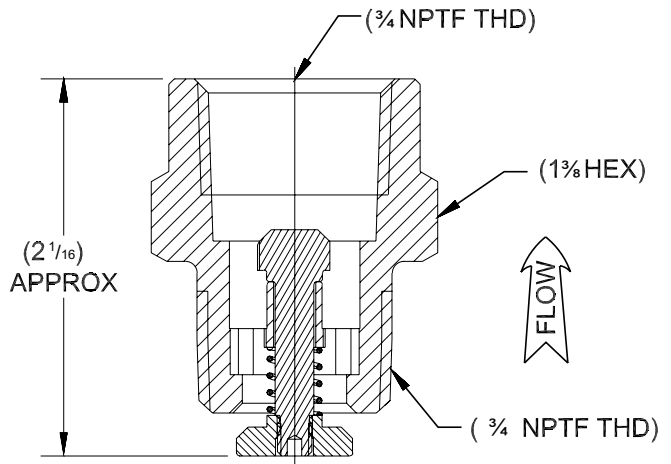
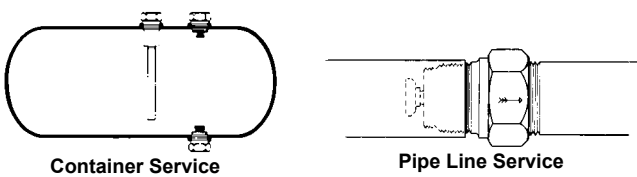

Ordering Information

Part Number	Inlet Connection	Outlet Connection	Wrench Hex Flats	Effective Length (Approx.)	Liquid (GPM Propane)
3272H	3/4"	3/4"	1 3/8"	1 3/8"	29

Excess Flow Valves for Container Service

A7537 Series, A7539 Series, A8523 and A8525

Application

Designed for mounting in threaded full or half couplings in container installations. They may be used for filling, withdrawal or vapor equalizing applications. The exceptionally low pressure drop makes them ideal for pump suction lines. If a riser pipe to the vapor space is used with these valves, the minimum inside diameter of the riser pipe must be at least two times the valve thread size in order not to restrict flow to the side inlet ports.

Features

- Precision machined.
- Generous flow channels provide low pressure drop minimizing cavitation in pump suction lines.
- Cotter pin prevents loss of spring retainer due to vibration in service.
- Stainless steel spring provides consistent closing flow and long service life.
- Separate models for installation in either half or full couplings.

Materials

Body	Cadmium Plated Steel
Body (A7539 Series Only)	Ductile Iron
Seat Disc	Cadmium Plated Steel
Stem	Stainless Steel
Spring	Stainless Steel
Guide	Cadmium Plated Steel



A7537N4

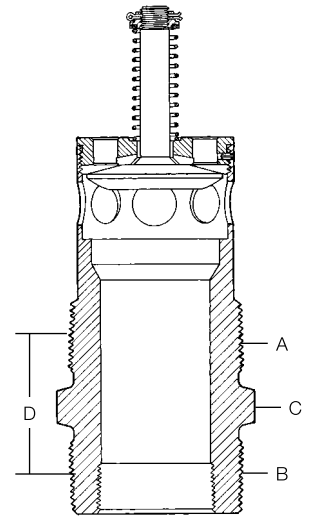

Typical Installation

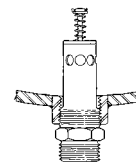

Half Coupling

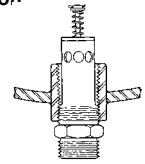

Full Coupling

Performance

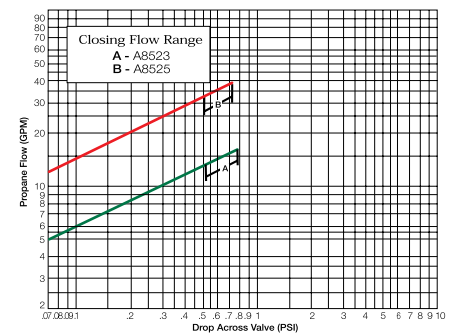
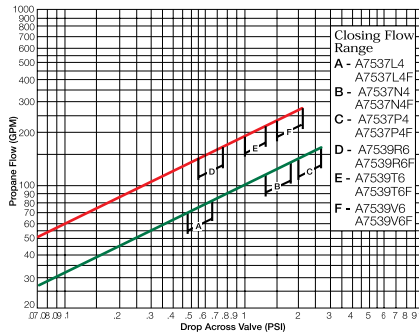

NOTE: Multiply flow rate by .94 to determine liquid butane flow and by .90 to determine liquid anhydrous ammonia flow.

Ordering Information

Part Number	For Use With This Type Coupling	A Inlet Connection M. NPT	B Outlet Connection NPT	C Wrench Hex Flats	D Effective Length (Approx.)	Approximate Closing Flow*		
						Liquid (GPM Propane)	Vapor SCFH (Propane)	
							25 PSIG Inlet	100 PSIG Inlet
A8523	Half	3/4"	3/4" Male	1 1/8"	1 3/4"	15	5,170	8,800
A8525	Half	1 1/4"	1 1/4" Male	1 1/4"	2 1/8"	35	12,540	21,560
A7537L4	Half	2"	2" Male and 1 1/4" Female	2 5/8"	2 1/2"	75	13,000	25,600
A7537L4F	Full					125	25,000	42,500
A7537N4	Half					150	30,500	52,000
A7537N4F	Full					150	32,100	55,500
A7537P4	Half	3"	3" Male and 2" Female	3 3/4"	3 1/8"	200	39,400	68,300
A7537P4F	Full					250	51,100	88,700
A7539R6	Half							
A7539R6F	Full							
A7539T6	Half							
A7539T6F	Full							
A7539V6	Half							
A7539V6F	Full							

* Based on horizontal installation of excess flow valve. Flows are slightly more when valves are installed with outlet up; slightly less when installed with outlet down.

Excess Flow Valves for Vapor or Liquid A2137 Series and 2139 Series

Application

Designed especially for filling, withdrawing or vapor equalizing in half and full coupling installations. Ideal for container service where welded-in dip pipes are not provided. For vapor use, mount in the bottom opening with a threaded dip pipe. For liquid use, mount in the top opening with a threaded dip pipe. These may also be installed in pipe lines provided the connection is made to the male inlet thread and not the female dip pipe connection.

Features

- Precision machined.
- Cotter pin helps prevent loss of spring retainer due to vibration in service.
- Stainless steel spring provides consistent closing flow and long service life.
- Generous flow channels provide low pressure drop.

Materials

A2137 Series

Body Cadmium Plated Steel
 Disc..... Cadmium Plated Steel
 Stem Stainless Steel
 Spring Stainless Steel
 Guide Cadmium Plated Steel

2139 Series

Body Brass
 Disc..... Brass
 Stem Stainless Steel
 Spring Stainless Steel
 Guide Brass

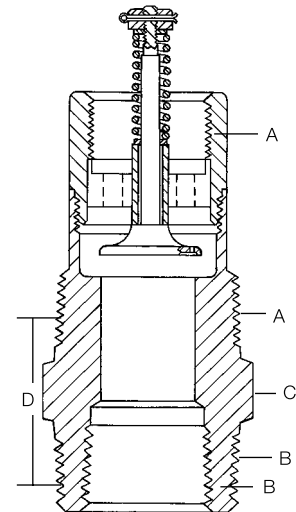

A2137

Typical Installations

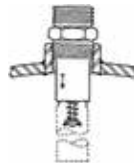

Container Service

Pipe Line Service

Performance

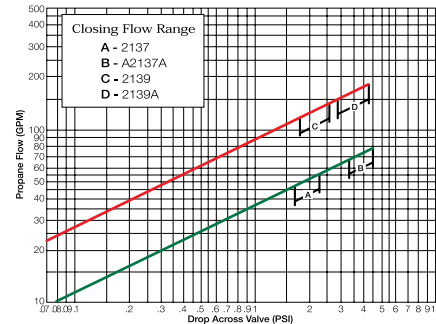

NOTE: Multiply flow rate by .94 to determine liquid butane flow and by .90 to determine liquid anhydrous ammonia flow.



Ordering Information

Part Number	A Inlet Connection NPT	B Outlet Connection F. NPT	C Wrench Hex Flats	D Effective Length (Approx.)	Approximate Closing Flows***		
					Liquid (GPM Propane)	Vapor SCFH (Propane)	
						25 PSIG Inlet	100 PSIG Inlet
A2137	2**	2" Male and 1 1/4" Female	2 7/16"	1 1/8"	50	10,000	17,000
A2137A					70	14,000	25,000
2139	3***	3" Male and 2" Female	3 1/2"	1 1/4"	125	26,500	46,000
2139A					160	32,700	57,200

* 1 1/4" F. NPT Dip Pipe Connection

** 2" F. NPT Dip Pipe Connection

*** Based on horizontal installation of excess flow valve. Flows are slightly more when valves are installed with outlet up; slightly less when installed with outlet down.

Excess Flow Valves for Flange Mounting in Container Service

A3500 Series and A4500 Series

Application

Designed for mounting in flanged tank connections with internal threads in the bottom of a container. They may be used in filling, withdrawal or vapor equalizing application. They provide high flow capacity with low pressure drop to minimize pump inlet line cavitation.

If a riser pipe to the vapor space is used with these excess flow valves, the minimum inside diameter of the riser pipe must be at least two times the valve thread size in order not to restrict flow to the side inlet ports.

Flange mounted excess flow valves are readily accessible for servicing and completely enclosed and protected in event of fire. Because there is no direct connection between external piping and the valve, stresses imposed on piping will not affect the excess flow valve.

Features

- Precision machined.
- Generous flow channels provide low pressure drop minimizing cavitation in pump suction lines.
- Cotter pin prevents loss of spring retainer due to vibration in service.
- Stainless steel spring provides consistent closing flow and long service life.

Materials

Body Cadmium Plated Steel
 Seat Disc Cadmium Plated Steel
 Stem Stainless Steel
 Spring Stainless Steel
 Guide Cadmium Plated Steel

Flanged Installation In Container

NOTE: The opening in the tank flange should be machined with a 1/4"-45° chamfer at the outer edge. The thread should be tapped one or two turns large as checked by a plug gauge. This and the undersize thread on the valve should permit the valve to be installed so that its outer face is at least flush with the outer edge of the flange.

The valve is screwed into this opening by fitting a 1/4" flat metal piece into the slot and turning until hand tight. A lubricant may be used, but a luting compound is not necessary since this joint does not have to be gas tight.

If any difficulty is experienced in "making up" the valve to fit flush, as indicated, the thread in the tank flange can be tapped.

Design and construction of tank and flange must be in accordance with the appropriate section of the ASME Pressure Vessel Code.

Ordering Information

Part Number	A Inlet Connection NPT	B For Installation	C Effective Thread (Approx.)	D Threaded End To Port	Approximate Closing Flows*		
					Liquid (GPM Propane)	Vapor SCFH (Propane)	
						25 PSIG Inlet	100 PSIG Inlet
A3500L4	2"	Slotted Body	3/4"	1 15/16"	75	13,000	22,500
A3500N4					125	25,000	42,500
A3500P4					150	30,500	52,000
A3500R6	3"		1"	1 1/8"	150	32,100	55,500
A3500T6					200	39,400	68,300
A3500V6					250	51,100	88,700
A4500Y8	4"		1 1/2"	1 5/8"	500	89,000	154,000

NOTE: Multiply flow rate by .94 to determine liquid butane flow and by .90 to determine liquid anhydrous ammonia flow.

* Based on horizontal installation of excess flow valve. Flows are slightly more when valves are installed with outlet up; slightly less when installed with outlet down.



A3500L4

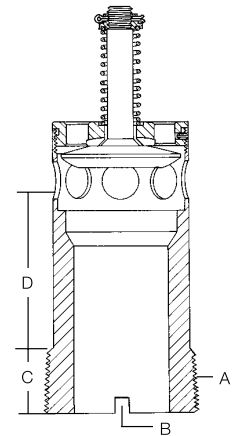

Performance

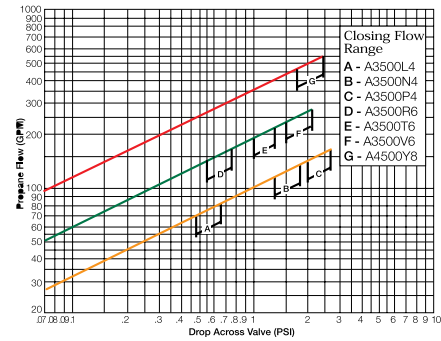

Specifications for companion flanges, gaskets, bolts and nuts must meet the appropriate codes, such as ASA B16.5.

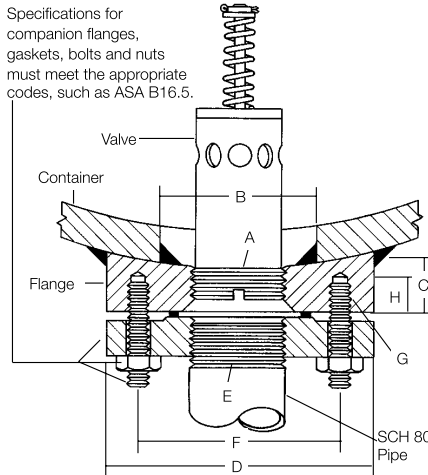

Key No.	Description	A3400L4, A3500L4, A3500N4, A3500P4	A3400L6, A3500R6, A3500T6, A3500V6	A4500Y8
A	Valve Size (NPT)	2"	3"	4"
B	Tank Opening	3 1/2"	4 1/2"	5 1/2"
C	Thickness (min.)	1"	1 1/4"	1 3/8"
D	Outside Diameter	6 1/2"	8 1/4"	10"
E	Pipe Thread (NPT)	2"	3"	4"
F	Bolt Circle Dia.	5"	6 1/2"	7 1/8"
	Number of Bolt Holes	8	8	8
G	Bolt Hole Thread	5/8" - 11 NC - 2	3/4" - 10 NC - 2	3/4" - 10 NC - 2
H	Bolt Hole Thread (min. eff.)	3/4"	1"	1 1/8"

Excess Flow Valves for Liquid or Vapor Withdrawal 2723C and A8013D Series

Application

These valves are designed for bottom mounting in consumer storage tanks for liquid service. They may also be top mounted for vapor service. These valves are designed especially for use with RegO globe and angle valves.

Features

- 2723C provides a 3/4" dip pipe inlet connection for top-mounted liquid or bottom-mounted vapor requirements.
- A8013D Series features a 2-position floating valve disc for faster, more efficient container filing.
- Precision machined.
- Stainless steel spring provides consistent closing flow and long service life.
- Generous flow channels provide low pressure drop.

Materials

A8013D Series

Body Cadmium Plated Steel
 Disc..... Stainless Steel
 Stem Stainless Steel
 Spring Stainless Steel
 Guide..... Cadmium Plated Steel
 Insert..... Stainless Steel

2723C

Body Brass
 Valve Poppet Brass
 Retainer..... Brass
 Spring Stainless Steel

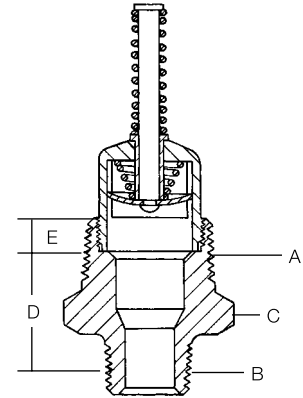

A8013D

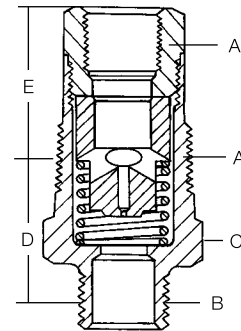

2723C

Performance

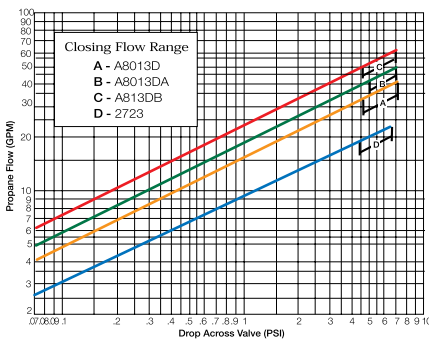

Typical Installation

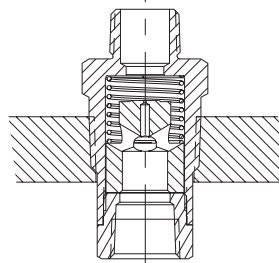

2723C

Container Service

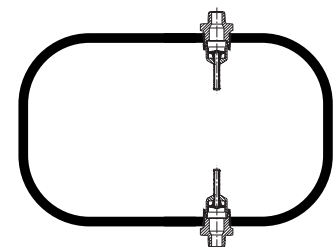

A8013D

Ordering Information

Part Number	A. Inlet Connection M. NPT	B. Outlet Connection NPT	C. Wrench Hex Flats	D. Effective Length (Approx.)	E. Threaded End To Port	Approximate Closing Flow**		
						Liquid (GPM Propane)	Vapor SCFH (Propane)	
							25 PSIG Inlet	100 PSIG Inlet
A8013D	1 1/4"	3/4"	1 3/4"	1 1/2"	-	39	8,700	14,700
A8013DA		1"		1 3/8"				
A8013DB		1 1/4"		1 7/8"				
2723C	1 1/4"	3/4"	1 1/8"	1 5/8"	1 15/16"	20	3,900	6,900

* 3/4" F. NPT Dip Pipe Connection

** Based on horizontal installation of excess flow valve. Flows are slightly more when valves are installed with outlet up; slightly less when installed with outlet down.

NOTE: Multiply flow rate by .94 to determine liquid butane flow and by .90 to determine liquid anhydrous ammonia flow.

Excess Flow Valve for Pressure Gauges 2884D

Application

Designed for container use in pressure gauge installations to minimize excess gas discharge in the event the pressure gauge is sheared. A suitable shut-off valve should be installed between this valve and the pressure gauge to allow convenient gauge replacement.

Features

- Precision machined.
- Suitable for use with all 1/4" M.NPT pressure gauges.

Materials

Body Brass
 Valve Brass
 Spring Stainless Steel
 Pin Stainless Steel

Ordering Information

Part Number	A. Inlet Connection M. NPT	B. Outlet Connection F. NPT	C. Wrench Hex Flats	D. Effective Length (Approx.)	E. Threaded End To Port	Approximate Closing Flow*		
						Liquid (GPM Propane)	Vapor SCFH (Propane)	
							25 PSIG Inlet	100 PSIG Inlet
2884D	3/4"	1/4"	1 1/16"	1 1/16"	1 5/16"	N/A	60	110

* Based on horizontal installation of excess flow valve. Flows are slightly more when valves are installed with outlet up; slightly less when installed with outlet down.

NOTE: Multiply flow rate by .94 to determine liquid butane flow.



2884D

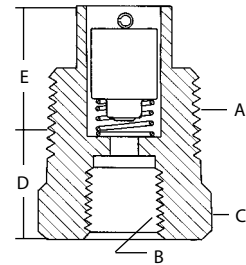

Excess Flow Valve for DOT Cylinders 3199W

Application

Designed for use on portable systems with vapor or liquid including torches, heaters, lead melting burners, tar and asphalt burners, wallpaper steamers and other applications involving portable DOT cylinders. The POL inlet attaches directly to the cylinder valve and the outlet mounts to the regulator.

Features

- Integral ball check design.
- Machined groove designed to break-off and allow excess flow valve to close.

Materials

Body Brass
 Nut Brass
 Bell Stainless Steel
 Spring Stainless Steel
 Retainer Spring Stainless Steel
 Retainer Brass



3199W

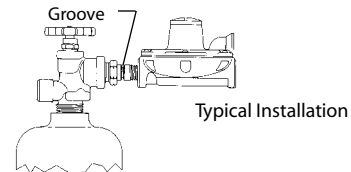
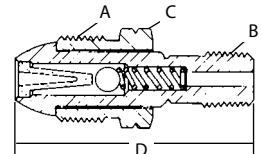

NOTE:

No protection is afforded should break-off occur downstream of the groove. Also, restrictions introduced by the regulator may prevent closing of the valve due to limited flow capacity. The valve's purpose is to protect the cylinder valve outlet should the regulator be broken off of its connection (at the groove), in which case it will close. It must not be depended upon to protect against breaks downstream of the regulator.

Ordering Information

Part Number	A. Inlet Connection	B. Outlet Connection	C. Wrench Hex Flats	D. Effective Length (Approx.)	Approximate Closing Flow*		
					Liquid (GPM Propane)	Vapor SCFH (Propane)	
						25 PSIG Inlet	100 PSIG Inlet
3199W	Male POL	1/4"	7/8"	2 1/16"	.95	265	500

* Based on horizontal installation of excess flow valve. Flows are slightly more when valves are installed with outlet up; slightly less when installed with outlet down.

NOTE: Multiply flow rate by .94 to determine liquid butane flow.

Chek-Lok® Excess Flow Valves

Designed to provide a convenient means of withdrawing liquid from stationary containers prior to moving the container.

NFPA Pamphlet 58 standards require: 1) containers with 125 gallons water capacity, or more, have a connection for liquid evacuation which is at least 3/4" NPT, and 2) containers designed for stationary use, have no more propane than 5% of their water capacity in liquid form during transportation. These rules apply to containers manufactured after July 1, 1961.

Chek-Lok® Operation

Instructions to Open Chek-Lok®

- 1 Loosen cap to vent any accumulated LP-Gas from the Chek-Lok. After venting stops, remove the cap. If venting does not stop, retighten the cap and use other approved means to withdraw liquid from the container.

NOTE: Use a suitable size wrench when removing the cap and adapter from the Chek-Lok. Do not allow the Chek-Lok to un-thread from the tank during removal. When necessary, use a second wrench to secure the Chek-Lok in position.

- 2 Before beginning withdrawal, securely connect a RegO 7550P angle valve or suitable shut-off valve to the adapter. Fully open the shut-off valve – the valve's handwheel must be fully opened before connecting adapter to tank.

- 3 Completely thread the adapter and shut-off valve assembly onto the Chek-Lok by turning adapter's coupling nut clockwise until it is tight. Immediately close the shut-off valve. Listen for an audible click to signal that the Chek-Lok has opened and is actuated for liquid withdrawal. The flow can now be controlled by the transfer valve.

- 4 Check the coupling nut and adapter assembly for leaks using a suitable leak detection solution.

If the Chek-Lok fails to open after following this procedure, the pressure downstream of the shut-off valve should be increased to equalize pressure in the Chek-Lok. It is simple to equalize pressures using vapor from either the vapor return valve or service valve, or from a hose end valve connected to the delivery truck.

Instructions to Close Chek-Lok®

- 1 To re-lock the Chek-Lok, container pressure must be in excess of 35 PSIG. Close shut-off valve and disconnect the hose or piping.
- 2 Open shut-off valve fully. Liquid discharging to the atmosphere should cause the excess flow feature of the Chek-Lok to close, provided tank pressure is 35 PSIG or more.

If, for any reason, the excess flow valve does not close, the shut-off valve must be closed immediately and must not be removed until the system can be evacuated and the unit repaired.

- 3 After the excess flow valve closes, remove the Adapter and Shut-Off Valve Assembly.
- 4 Clean face of Chek-Lok and install the Cap with a gasket. IMPORTANT: Only use the proper Chek-Lok Cap. Do not use a standard pipe cap.

The Chek-Lok® permits one transfer shut-off valve with an adapter to be used interchangeably on a number of tanks. With a Chek-Lok® on each tank and a high capacity RegO 7550P Series transfer valve and adapter on all your service and delivery trucks – the need for individual transfer valves is eliminated. This provides a substantial savings without sacrificing safety.

Connecting the 7590U or 7591U Chek-Lok®

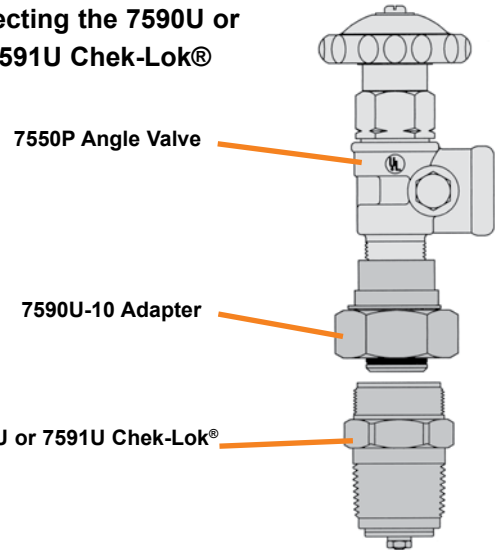

Connecting the 7572FC or 7580FC Chek-Lok®

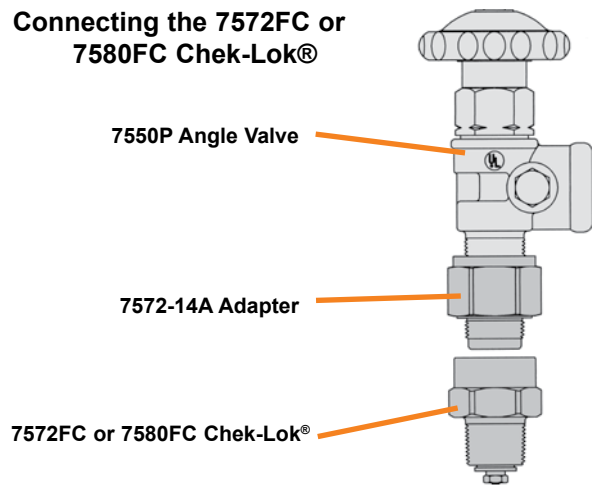

In the absence of a 7550P transfer valve, a 3/4" A7505A Globe Valve or A7506AP Angle Valve may be used. Follow the above procedures using the 7572C-15A adapter instead of the 7572C-14A. Use a RegO 7550P without an adapter in an emergency only.

CAUTION: Always wear approved protective gloves when working with the Chek-Lok®. Do not vent LP-Gas near possible source of ignition.

Chek-Lok® Mounting

Chek-Lok® Valves may be either top mounted with a dip tube or bottom mounted. For bottom mounting, it is preferable to position the coupling in the head or slightly off of the bottom. This helps prevent the accumulation of sludge, etc. around the valve which could affect the proper operation of the excess flow valve.

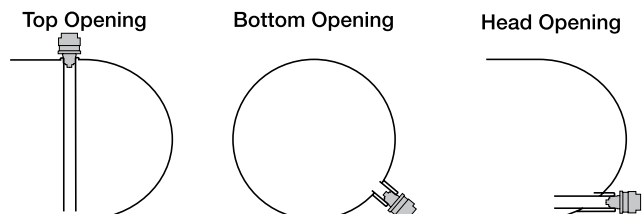

Chek-Lok® Excess Flow Valves

7590U and 7591U Series

Application

Chek-Lok® Excess Flow Valves are designed to provide a convenient means of withdrawing liquid from stationary containers prior to moving the container. The Chek-Lok® permits one transfer shut-off valve with an adapter to be used interchangeably on a number of tanks.

The 7590U and 7591U Chek-Loks® are also designed for use on permanent installations provided the excess flow valve is sized properly for the system and piping. NOTE: In some cases, it may be necessary to use an in-line excess flow valve to protect the downstream piping. This valve is not recommended for use as a liquid source for pumps.

Features

- Extra strength connection between body and adapter provides increased strength.
- Weep hole in cap provides indicator to verify Chek-Lok® is closed before cap removal.
- Heavy duty brass cap requires at least 3½” full turns for removal.
- O-ring seal on adapter provides a gas tight seal before the adapter opens the equalizing stem.
- Eliminates need for individual transfer valves at each container.
- UL listed.



7590U with Cap

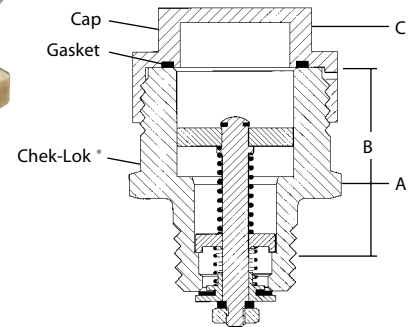

Materials

Body	Brass
Stem	Brass
Spring	Stainless Steel
Seals	Synthetic Rubber
Valve Poppet	Brass
Gasket	Nylon

Ordering Information

Chek-Lok® Number	Inlet Connection	Outlet Connection	A. Body Wrench Hex Flats	B. Approximate Effective Length	C. Cap Wrench Hex Flats	Approximate Closing Flow, Liquid GPM (Propane)*
7590U	¾" M. NPT	1½" UNF	1¼"	1¼"	1¼"	20
7591U	1¼" M. NPT		1¼"	1½"		35

* Based on horizontal installation of excess flow valve. Flows are slightly more when valves are installed with outlet up, and slightly less when installed with outlet down. Note: Multiply flow rate by .94 to determine liquid butane flow.

Chek-Lok® Liquid Evacuation Adapter for 7590U and 7591U Valves

7590U-20

Application

Designed specifically for use with RegO 7590U and 7591U Chek-Lok® Excess Flow Valves. Adapter's operating handle opens and closes equalizing stem in the Chek-Lok® valve. Eliminates gas flow through Chek-Lok® valve when installing or removing adapter. Use of RegO adapter ensures proper connections and opening of the check mechanism.

Features

- Built in nylon gasket provides a gas tight seal.
- Adapter can be installed without depressing the equalizing stem of the Chek-Lok®.
- Design eliminates the need to slug excess flow feature of Chek-Lok® when removing the adapter.
- Built in bleeder valve allows controlled discharge of liquid before removing the adapter.



7590U-20

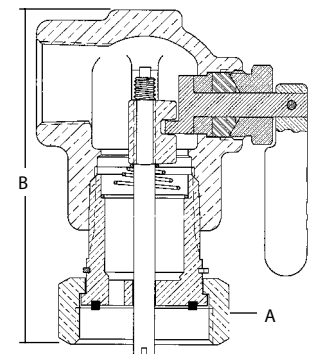

Ordering Information

Adapter Number	Inlet Connection	Outlet Connection	A Wrench Hex Flats	B Approximate Length
7590U-20	1½-12 UNF	¾"	1¼"	4¾"

7580F-20 Liquid Evacuation Adapter for older design 7572FC and 7580FC Chek-Lok® Valves

Application

Designed specifically for use with RegO 7572FC and 7580FC Chek-Lok® Excess Flow Valves. The adapter's operating handle opens and closes the equalizing stem in these older style Check-Lok® valves. This adapter is designed to eliminate the need for gas to flow from the Chek-Lok® when the adapter is installed or removed. A shutoff valve, such as a full port ball valve must be installed at the outlet of the 7580F-20.

Features

- Built in nylon gasket provides a gas tight seal.
- Adapter can be installed without depressing the equalizing stem of the Chek-Lok®.
- Design eliminates the need to slug the excess flow feature of the Chek-Lok® when removing the adapter.
- Built in bleeder valve allows for controlled discharge of liquid before removing the adapter.

Ordering Information

Adapter Number	Inlet Connection	Outlet Connection	Approximate Length	Wrench Hex Flats
7580F-20	3/4" M.NPT	3/4" F. NPT	4 3/32"	1 3/8"



7580F-20

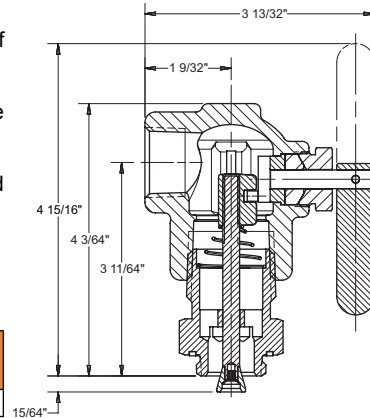

Union Style Adapters for 7590U and 7591U Valves

The 7590U-10 adapter must be used to connect to the 7590U and 7591U Chek-Lok. This insures a proper connection to open the check mechanism. A built-in nylon gasket provides a gas tight seal.



7590U-10

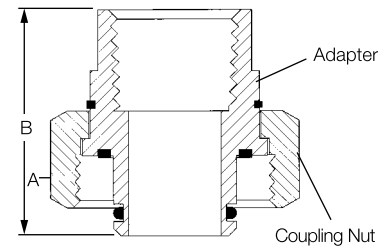

Ordering Information

Adapter Number	Inlet Connection	Outlet Connection	A. Wrench Hex Flats	B. Approximate Length
7590U-10	1 1/8" UNF	3/4" F. NPT	1 3/4"	1 1/8"

Adapters for 7572FC and 7580FC Valves

These adapters must be used to connect to the 7572FC and 7580FC Chek Loks to open the check mechanism properly. A built in nylon gasket provides a gas tight seal.



7572C-14A
For Transfer Valves



7572C-15A
For Globe and Angle Valves

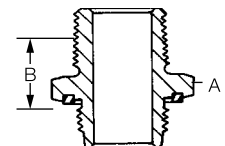
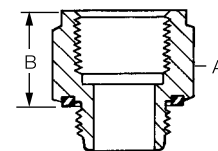

Ordering Information

Adapter Number	Inlet Connection	Outlet Connection	A. Wrench Hex Flats	B. Approximate Effective Length
7572C-14A	3/4" M. NPT	3/4" F. NPT	1 3/8"	1"
7572C-15A		3/4" M. NPT		3/4"

Double-Check Filler Valves

General Information

RegO Double-Check Filler Valves incorporate a resilient upper check valve, normally designated as a filler valve, and a lower check valve, commonly called a back pressure check valve. Available in a range of sizes to cover virtually all LP-Gas storage containers, these valves are UL listed and meet NFPA standards, as well as other safety requirements.

Flow of liquid into the storage container opens both check valves. When flow stops, they both are designed to close automatically to permit the operator to disconnect the hose coupling. The automatic closing action also helps prevent the discharge of container contents in the event of hose failure. The lower back pressure check affords extra protection by restricting the discharge if the upper check fails to function properly due to accidents or other causes.

The double back check construction allows emergency inspection, repair, or replacement of the upper fill assembly without removing product from the container. When the upper filler valve body is removed, the lower back check valve provides a seal, permitting only some leakage, allowing a new upper filler valve body to be installed.

Spare Gasket Ordering Information

ACME	Part Number
1¼"	A2797-20R
1¾"	A2697-20R
2¼"	A3184-8R
3¼"	A3194-8R



Double-Check Filler Valves for Large DOT and ASME Tanks L6579 Series and L7579 Series

Application

Designed to provide fast filling of large motor fuel and ASME domestic tanks. The 6579 Series incorporates a swing-away lower check which greatly reduces pressure drop across the valve. This lower pressure drop promotes faster filling rates and greater efficiency resulting in more profitable operations.

Features

- Low emission- 2.14 cubic centimeters at disconnect (2.14cc versus 6.85cc)
- Double back check provides added system protection.
- Upper filler valve assembly can be easily replaced without evacuating the container.
- Both checks are spring actuated for quick, precise closure when flow into the valve stops or reverses.
- 6579 Series swing-away check promotes faster filling for more profitable operations.
- Specify RegO Filler Valves on all your original tank purchases to ensure quality and dependable performance.

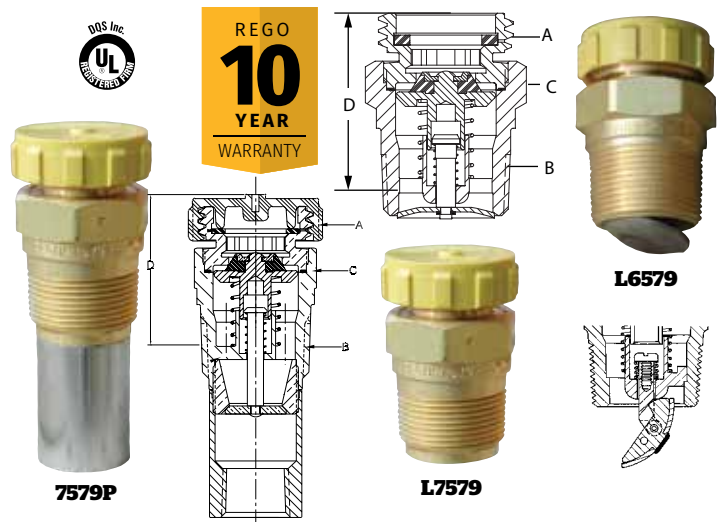

Materials

Upper Body.....	Brass
Lower Body.....	Brass
Springs	Stainless Steel
Washer and Seat Disc.....	Synthetic Rubber
Cap.....	Plastic

Ordering Information

Part Number		A. ACME Hose Connection	B. Tank Connection M. NPT	C. Wrench Hex Flats	D. Effective Length (Approx.)	Propane Liquid Capacity at Various Differential Pressures (GPM)				
Basic	With Cap & Lanyard					5 PSIG	10 PSIG	25 PSIG	50 PSIG	75 PSIG
L7579	L7579C	1¼"	1¼"	1⅝"	1 ²⁷ / ₃₂ "	50	70	111	157	192
7579P*	-				2 ¹ / ₃₂ "	37	52	82	116	142
L6579**	L6579C**				1 ²⁷ / ₃₂ "	78	110	174	246	301
L6579										

* Incorporates ¼ F. NPT dip pipe connection

** Swing-away lower back check valve design for higher filling rate. NOTE: Multiply flow rate by .94 to determine liquid butane capacity.

New Low Emission Filler Valve with Manual Shutoff Feature

7501L & 7502L

General Information

RegO Manual Double-Back Check filler valves that incorporate a resilient upper check and a **manual shutoff feature**. When filling a container from a delivery truck, this valve will allow flow into the container through the upper and lower check, when the manual lever is in the open position. When flow stops both the upper and lower checks will close; the lever is then turned to the closed position, the hose-end valve can then be removed from the filler valve.

Application

Designed for fast filling of larger DOT cylinders and ASME domestic containers; the 7501L and 7502L feature a manual shutoff in addition to upper and lower back checks.

Features

- Low emission 2 cc or less at disconnect.
- Meets NFPA 58 and UL requirements.
- Double back check provides added system protection.
- Checks are spring activated for quick precise closure when flow stops.
- Manual shutoff valve is designed to provide additional system protection when disconnecting hose end valve from filler valve.
- Hose end valve cannot be removed from the 7501L or 7502L if the lever is in the open position.
- When manual shutoff valve is closed, an integral back check prevents liquid from being trapped between the shutoff and the upper check.



CE 0036

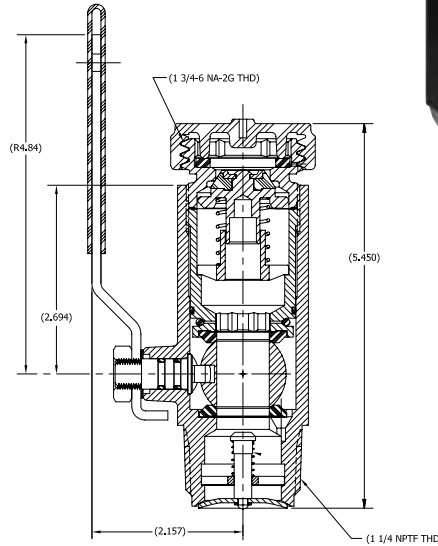

7501L



7502L

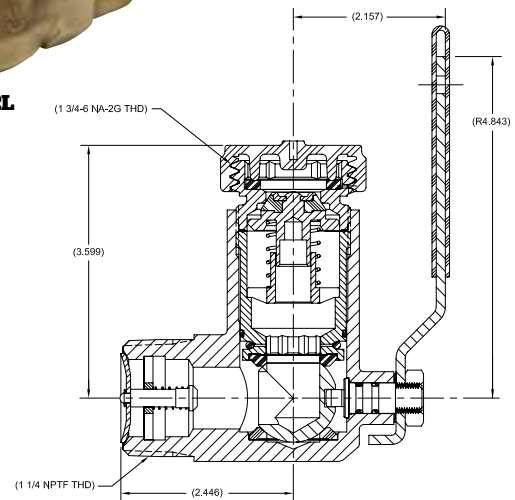

Ordering Information

Part Number	Container Connection	ACME Hose Connection	Propane Liquid Capacity at Various Differential Pressures		
			15 PSIG	25 PSIG	50 PSIG
7501L	1 1/4" M.NPT	1 1/4" M.ACME	62 GPM	90 GPM	6125 GPM6
7502L					

Combination Filler and Overfill Protection Device (OPD) Low Emissions SF7647V Series

Application

This combined filler valve and overfill protection device is designed to provide fast filling and protection against overfilling of Vertical above ground small bulk type containers. The SF7647V Series offers good fill rates and an overfill prevention device that will stop* the flow of product into the container when the liquid level reaches 80-83% of its capacity.

Features

- Large flow area for fast filling.
- Resilient seated upper check.
- Stable Overfill Protection Device that is integral to the filler valve.
- Overfill Protection Device will stop the flow of liquid when the 80-83% level is reached.

Materials

Upper body Brass
 Lower body Brass
 Springs Stainless Steel
 Washer and seat disc Synthetic Rubber
 Cap Plastic
 OPD check Nylon
 OPD lever and riser Nylon
 OPD float Closed Cell Nitrile

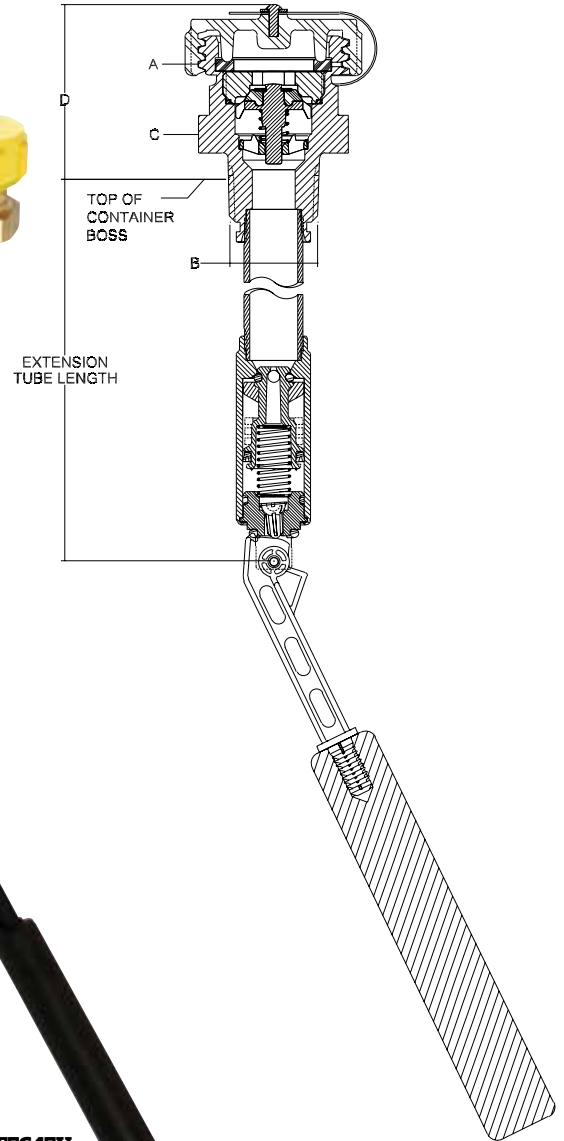

Ordering Information

Part Number	Propane Liquid Capacity at 20 PSIG differential pressure gallons/minute	Propane Liquid Capacity at 30 PSIG differential pressure gallons/minute	Propane Liquid Capacity at 50 PSIG differential pressure gallons/minute
SF7647V11.0	19	24	50
SF7647V11.1			

Combination Low Emission Filler and Overfill Protection Device (OPD) SFL7579V Series

Application

The SFL7579V Series filler valve is for use on ASME containers. This combined filler valve and overfill protection device is designed to provide fast filling and protection against overfilling of vertical and horizontal above ground LPG containers. This is typically installed in the top of horizontal containers.

Features

- Low emission filler valve, will not release more than 2.14cc when disconnected.
- Large flow area for fast filling.
- Resilient seated upper check.
- Stable Overfill Protection Device that is integral to the filler valve.
- Overfill Protection Device will stop the flow of liquid when the 80% level is reached.

Note:

- Must be installed in a vertical position.
- Depending on the application this valve is designed to be used in conjunction with another device such as a fixed liquid level gauge or float gauge in low emission transfer systems.



SFL7579V

Materials

Upper body	Brass
Lower body	Brass
Springs	Stainless Steel
Washer and seat disc	Synthetic Rubber
Cap	Resilient Molded Plastic
OPD check	Nitrile
OPD lever and riser	Nylon
OPD float	Closed Cell Nitrophenolic

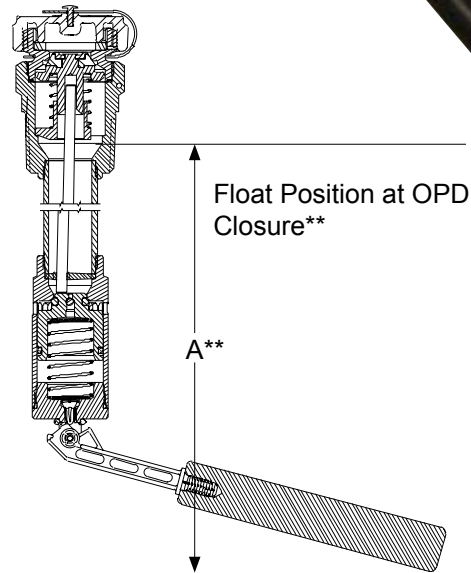

Ordering Information

Part Number**	ACME Hose Connection	Tank Connection M/NPTF	Wrench Hex Flats	Length A*	Propane Liquid Capacity at Various Differential Pressures GPM			
					1 PSI	25 PSI	50 PSI	75 PSI
SFL7579V13.8	1 1/4" Male	1 1/4"	1 1/2"	14.43"	23	49	54	66
SFL7579V13.0				13.63"				
SFL7579V12.3				12.93"				
SFL7579V11.1				11.73"				
SFL7579V10.6				11.23"				

* Distance from center thread to float at closure.

** Suffix number indicates dip tube length (Fixed liquid level gauge) different lengths available upon request.

Double Check Low Emission Filler Valves for Forklift and DOT Containers 7647 Series

Application

Designed to provide fast filling of forklift, motor fuel, and recreational vehicle tanks.

Features

- Resilient seat disc in lower check designed to provide a gas tight seal without leakage.
- Double back check provides added system protection.
- 7647SA has 30° angle on hose connection. Makes connection and disconnection easier for certain engine fuel applications.
- Large 1 3/4" wrench flats on 7647SC allow use of socket wrench for easy installation.
- Specify RegO Filler Valves on all your original tank purchases to ensure quality and dependable performance.

Materials

Upper Body.....	Brass
Lower Body.....	Brass
Springs.....	Stainless Steel
Washer and Seat Discs.....	Resilient Synthetic Rubber
Cap.....	Plastic



Lanyard and Cap



7647SC

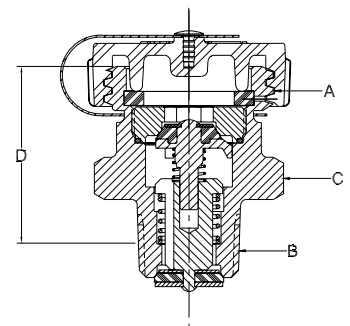

7647DC

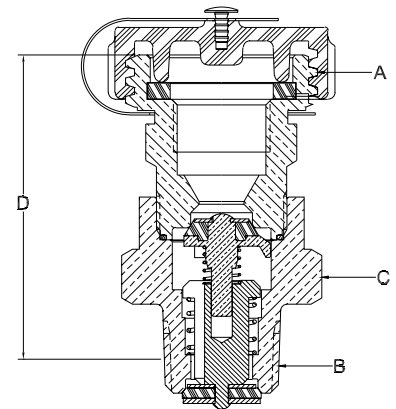

Ordering Information

Part Number	A Hose Connection	B Tank Connection M. NPT	C Wrench Flats	D Effective Length (Approx.)	Propane Liquid Capacity at Various Differential Pressures (GPM)**				
					10 PSIG	20 PSIG	30 PSIG	40 PSIG	50 PSIG
7647DC	1 3/4" ACME + F. POL	3/4"	1 3/4"	2 9/16"	14	20	24	27	50
7647SC*	1 3/4" ACME		1 3/4"	1 11/16"*					

* Large 1 3/4" hex wrench flats.

** Multiply flow rate by .94 to determine liquid butane capacity.

Double Check Filler Valves for Delivery Truck Tanks and Large Storage Containers 7579S, 6587EC and 3197C

Application

Designed to provide fast filling of bobtails, transports and large bulk storage tanks.

The 6587EC incorporates a swing-away lower check which greatly reduces pressure drop across the valve. This lower pressure drop promotes faster filling rates and greater efficiency resulting in more profitable operations.

Features

- Double back check provides added system protection.
- Upper filler valve assembly can be easily replaced without evacuating the container.
- Both checks are spring actuated for quick, precise closure when flow into the valve stops or reverses.
- 6587EC swing-away check promotes up to 65% faster filling rates for more profitable operations. Faster filling rates add longer pump life by reducing chances of cavitation.
- Specify RegO Filler Valves on all your original tank purchases to ensure quality and dependable performance.

Materials

Upper Body.....	Brass
Lower Body (7579S and 6587EC).....	Brass
Lower Body (3197C).....	Plated Steel
Springs	Stainless Steel
Washer and Seat Discs	Synthetic Rubber
Cap (6587EC and 3197C).....	Brass
Cap (7579S).....	Plastic



7579S

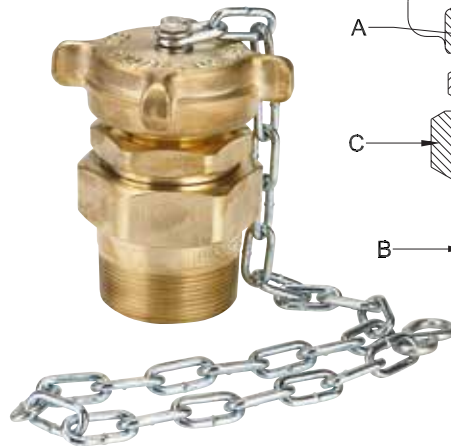
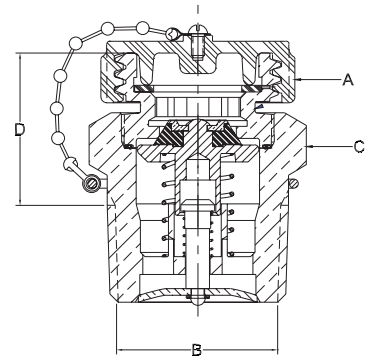

6587EC

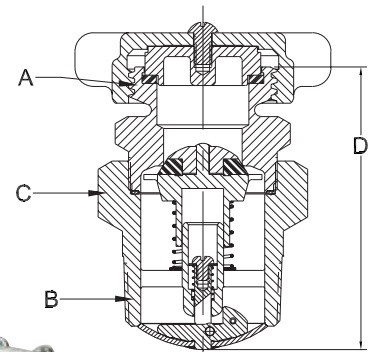

3197C

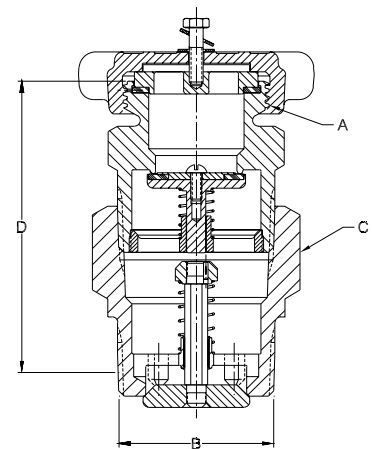

Ordering Information

Part Number	A. ACME Hose Connection	B. Tank Connection M. NPT	C. Wrench Hex Flats	D. Effective Length (Approx.)	Propane Liquid Capacity at Various Differential Pressures (GPM)				
					5 PSIG	10 PSIG	25 PSIG	50 PSIG	75 PSIG
7579S	1 3/4"	1 1/2"	2"	2 1/16"	44	62	98	139	170
6587EC*	2 1/4"	2"	2 5/8"	4 3/8"	92	130	206	291	356
3197C	3 1/4"	3"	4"	6 1/2"	148	210	332	470	575

* Swing-away lower back check valve design for higher filling rates.
NOTE: Multiply flow rate by .94 to determine liquid butane capacity.

Single Check Filler Valves for Storage Tanks with Supplementary Back Check Valves 3174C, 3194C and 6584C

Application

Designed for use with RegO Back Check Valves to provide fast filling of bulk storage tanks. Also may be used as a spare or replacement part.

These single check filler valves must never be installed directly into container couplings. They must be used with the appropriate back check valve to comply with NFPA Pamphlet #58.

Features

- Specifically for use with RegO Back Check Valves.
- 6584C stem assembly reduces turbulence during filling and promotes higher filling rates.
- Specify RegO Filler Valves on all your original tank purchases to ensure quality and dependable performance.

Materials

Upper Body.....	Brass
Lower Body	Brass
Springs	Stainless Steel
Washer and Seat Discs	Synthetic Rubber
Cap (3194C, 6584C)	Brass
Cap (3174C).....	Plastic



3174C



3194C, 6584C

Ordering Information

Part Number	ACME Hose Connection	Outlet Connection M. NPT	Wrench Hex Flats	Propane Liquid Capacity at Various Differential Pressures (GPM)				For Use With Back Check Valve:
				5 PSIG	10 PSIG	25 PSIG	50 PSIG	
3174C	1 3/4"	1 1/4"	1 11/16"	23	33	52	74	3176
6584C*	2 1/4"	2"	2 3/8"	156	220	348	492	A3186
3194C	3 1/4"	3"	3 1/2"	147	208	329	465	A3196

* Stem Assembly designed for higher filling rates.
NOTE: Multiply flow rate by .94 to determine liquid butane capacity.

Vapor Equalizing Valves

General Information

RegO Vapor Equalizing Valves consist of an upper back check valve and lower excess flow valve. In the closed position, the attachment of a vapor hose coupling with its projecting nozzle, opens the back check valve to permit flow in either direction. The lower excess flow valve is designed to close automatically when flow out of the container being filled exceeds the rated capacity. The valve closes automatically when the coupling is removed. Like the double-check filler valves, the vapor equalizing valves utilize a two-piece body construction. The lower excess flow valve will permit some leakage when the upper back check valve is removed for emergency repairs or replacement.

RegO Vapor Equalizing Valves are designed for use in both ASME and DOT containers.



Seal cap made of tough, resilient molded plastic. Protects threads and internal working parts. Caps are designed to contain normal tank pressures, and must be kept on valves at all times.

Long-wearing gasket permits hand-tight connection of cap and hose coupling.

Seat disc of special synthetic composition is extra thick for longer life.

Valve guide is precision machined to ensure positive seal.

Spare Gasket Ordering Information

ACME	Part Number
1 1/4"	A2797-20R
1 3/4"	A2697-20R

Double Check Vapor Equalizing Valves for ASME and DOT Containers

7573 Series and 3183AC

Application

Designed to facilitate loading operations by providing equalization of pressures in the supply and storage containers. The supplementary excess flow valve closes when the flow from the container being filled exceeds a predetermined rate.

The 7573 Series is designed for use in bulk delivery systems and motor fuel containers. The 3183AC is designed for use in delivery trucks and other large containers.

Features

- Double check provides added system protection.
- Specify RegO Vapor Equalizing Valves on all your original tank purchases to ensure quality and dependable performance.

Materials

Body Brass
 Spring Stainless Steel
 Upper Check Seat + ACME Synthetic Rubber
 Body Gasket Copper
 Cap Plastic

Ordering Information

Part Number		A. ACME Hose Connection	B. Tank Connection M. NPT	C. Wrench Hex Flats	D. Effective Length (Approx.)	Approx. Closing Flow at 100 PSIG Inlet Pressure (SCFH/Propane)
Basic	W/ Chain & Cap					
7573D	7573DC	1 1/4"	3/4"	1 3/8"	1 1/2"	4,100
-	3183AC	1 1/4"	1 1/4"	2"	2 3/32"	10,000



7573 Series

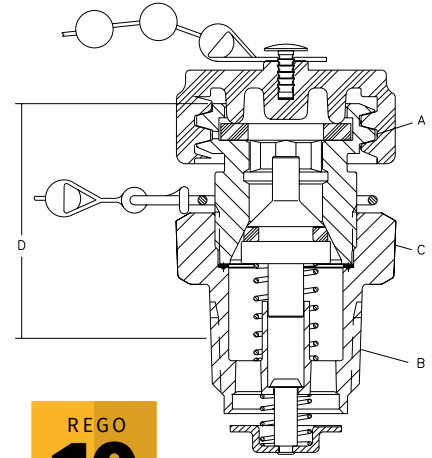

F

Single Check Vapor Equalizing Valves for ASME and DOT Containers

with Supplementary Excess Flow Valves

Application

Designed for use with RegO Excess Flow Valves to facilitate loading operations by providing equalization of pressures in the supply and storage containers. Also may be used as a spare or replacement part. These vapor equalizing valves must never be installed directly into container couplings. They must be used with the appropriate excess flow valve to comply with NFPA Pamphlet #58.

Features

- Specifically for use with RegO Excess Flow Valves.
- Specify RegO Vapor Equalizing Valves on all your original tank purchases to ensure quality and dependable performance.

Materials

Body Brass
 Spring Stainless Steel
 Seat Disc Synthetic Rubber
 Seal Synthetic Rubber
 Cap Plastic

Ordering Information

Part Number		A. ACME Connection	B. Tank Connection M.NPT	C. Wrench Hex Flats	D. Effective Length (Approx.)	Approximate Closing Flow at 100 PSIG Inlet Pressure (SCFH/Propane Vapor)	For Use With Excess Flow Valve:
Basic	With Cap & Chain						
3170	-	1 1/4"	3/4"	1 1/4"	1 1/8"	7,600	3272E
-	3180C	1 1/4"	1 1/4"	1 1/16"	1 1/2"	10,000	3282A



3170

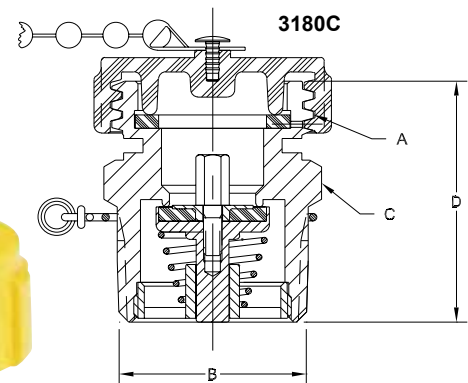

Back Pressure Check Valves

General Information

RegO Back Pressure Check Valves are designed to allow flow in one direction only. The check, normally held in the closed position by a spring, precludes the possibility of flow out of the container. When flow starts into the container, the pressure overcomes the force of the spring to open the check. When the flow stops or reverses, the check closes.

Metal-to-metal seats will allow slight leakage after closure. These valves will restrict the escape of container contents in the event of accidental breakage of the piping or fittings.

Back Pressure Valves for Container or Line Applications 3146 Series, 3176 Series, A3186, A3187S, A3196, and A3276BC

Application

Designed to provide protection of a container opening when desired flow is always into the vessel. May be used in line applications where flow must be limited to one direction.

When used with the appropriate single check filler valve, the combination forms a double check filler valve suitable for use in filling of bulk storage tanks.

Features

- Generous flow channels for low pressure drop.
- Heavy-duty construction for long service life.
- Soft seat valves have synthetic rubber seat disc for positive seals.

Materials

Body (3146, 3146S, 3176)	Brass
Body (all others)	Cadmium Plated Steel
Disc (3146, 3146S, 3176)	Brass
Disc (all others)	Cadmium Plated Steel
Stem (3146, 3146S, 3176)	Brass
Stem (A3146, A3196, A3276BC)	Stainless Steel
Stem (A3176, A3186)	Cadmium Plated Steel
Spring	Stainless Steel
Seat Disc (3146S, A3276BC)	Synthetic Rubber

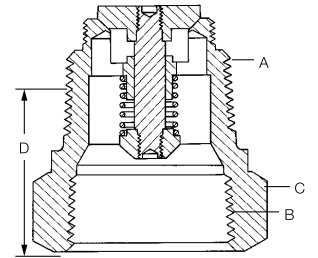

3146 Series, 3176 Series, A3186, A3196

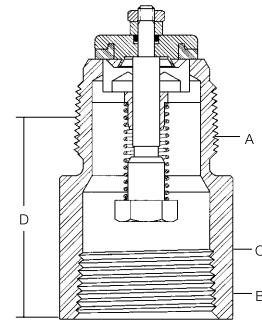

A3276BC

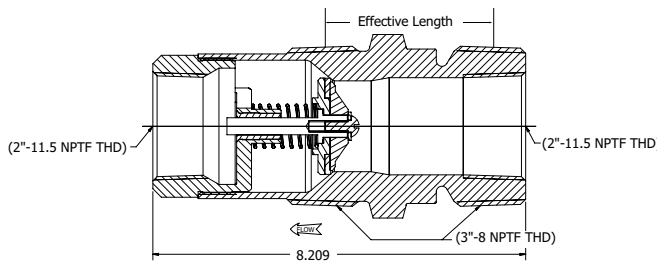

A3198S



A3187S

Container Service

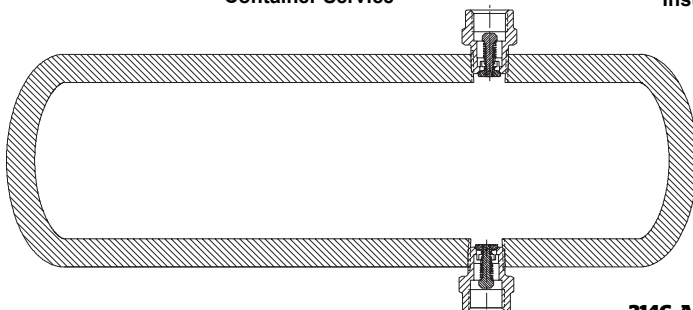

Installation

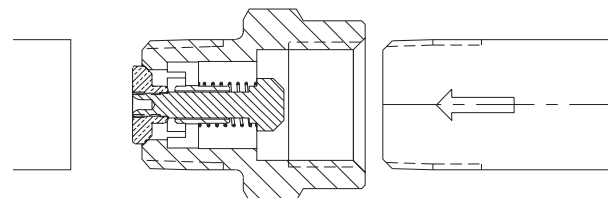

Typical Installation

3146, A3146, 3146S, 3147S, A3276BC, 3176, A3176, A3186, A3196

Back Pressure Valves for Container or Line Applications

3146 Series, 3176 Series, A3186, A3187S, A3196, and A3276BC

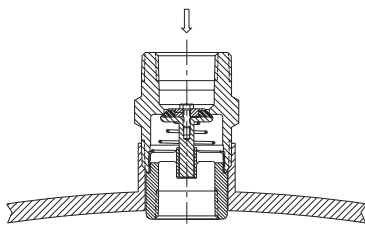

A3187S Container Service

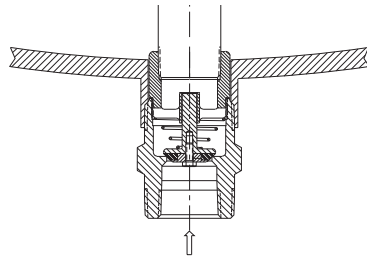

A3187S Pipe Line Service

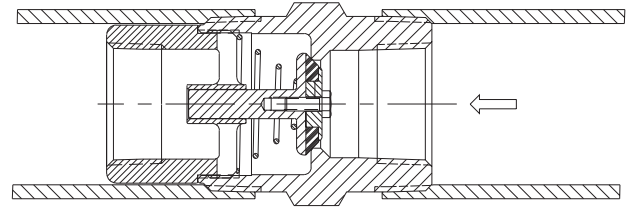

Ordering Information

Part Number		A Inlet Connection F. NPT	B Outlet Connection M. NPT	C Wrench Hex Flats	D Effective Length (approx.)	Propane Liquid Capacity at various differential pressures (GPM)			
Brass	Steel					5 PSIG	10 PSIG	25 PSIG	50 PSIG
3146	A3146	3/4"	3/4"	1 3/8"	1 15/16"	11	16	25	36
3146S*									
3176	A3176	1 1/4"	1 1/4"	2"	1 13/32"	28	40	63	89
	A3276BC*				2 1/8"	32	45	73	103
	A3186	2"	2"	3"	2 3/8"	124	175	276	391
	A3187S*	2" M & 1 1/4" F	2" M & 1 1/4" F	2 3/8"	1 27/32"	60	110	225	350
	**								
	A3196	3"	3"	4"	3 7/32"	297	420	664	939
	A3198S*	3" M & 2" F	3" M & 2" F	3 1/2"	3 1/4"	210	290	400	
	**								

*Soft seat version.

**The 1 1/4" and 2" outlet connections are for a standpipe when installed inside of a container.

NOTE: Multiply flow rate by .94 to determine liquid butane capacity and by .90 to determine liquid anhydrous ammonia capacity.

Swing-Away Back Pressure Check Valves for Container or Line Applications

6586D and A6586D

Application

Designed to provide protection of a container opening when desired flow is always into the vessel. May also be used in the line applications where flow must be limited to one direction.

When used with the appropriate single check filler valve, the combination forms a double check filler valve suitable for use in filling of bulk storage tanks.

The swing-away check offers more efficient flow rates than conventional designs. It swivels open vertically to reduce pressure drop across the valve and improves flow rates.

Features

- Swing-away check design offers faster flow rates.
- Heavy-duty construction for long service life.



6586D

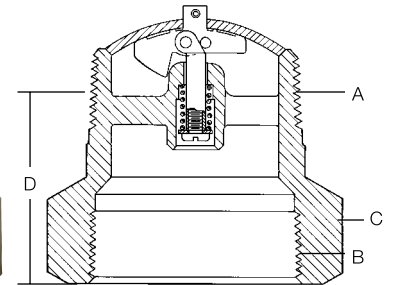

Materials

Body (6586D)	Brass
Body (A6586D)	Steel
Disc	Stainless Steel
Stem Assembly	Stainless Steel
Spring	Stainless Steel
Screw	Stainless Steel



Ordering Information

Part Number		A. Inlet Connection F. NPT	B. Outlet Connection M. NPT	C. Wrench Hex Flats	D. Effective Length (Approx.)	Propane Liquid Capacity at Various Differential Pressures (GPM)			
Brass	Steel					5 PSIG	10 PSIG	25 PSIG	50 PSIG
6586D		2"	2"	2 3/4"	2 1/2"	190	270	420	600
	A6586D			2 1/8"					

NOTE: Multiply flow rate by .94 to determine liquid butane capacity.

Back Pressure Check Valves for Flanged Installation A3400L4 and A3400L6

Application

Designed to provide high flow capacity and allow more efficient tank filling than conventional designs. The unobstructed throat area reduces flow turbulence through the valve, thereby reducing pressure drop. Large flow channels and spacious side ports ensure ample capacity for the most demanding high capacity filling operations.

The valve is designed for installation in internally threaded flanges in container bottoms.

Features

- Speeds up filling operations in bulk tanks.
- All steel and stainless steel construction ensures long service life.

Materials

Body	Cadmium Plated Steel
Stem	Stainless Steel
Spring	Stainless Steel
Disc	Cadmium Plated Steel
Guide	Stainless Steel
Roll Pin	Stainless Steel

Ordering Information

Part Number	A. Flange Connection M. NPT	B. Wrench Hex Flats	C. Overall Length	D. Threaded End To Port	Propane Liquid Capacity at Various Differential Pressures (GPM)			
					5 PSIG	10 PSIG	25 PSIG	50 PSIG
A3400L4	2"	Slotted	5 1/4"	1 1/16"	223	316	500	707
A3400L6	3"		5 3/2"	1 1/16"	424	600	949	1342

NOTE: For installation in flange tank connections with internal threads, see the "Flanged Installation in Container" section under "Excess Flow Valves." Multiply flow rate by .94 to determine liquid butane capacity and by .90 for liquid anhydrous ammonia capacity.

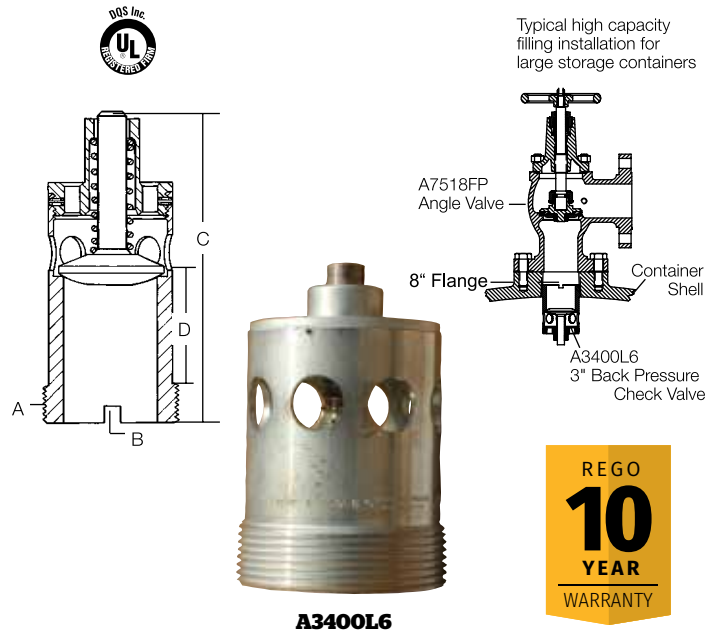

Adhesive Warning Labels 903-500 and 7572-400

The following warning information, Part Number 903-500, is included with each shipment of Excess Flow, Check, Filler and Vapor Equalizing Valves to the first purchaser of the product from the factory.

This information is intended to be forwarded throughout the product distribution chain. Additional copies are available from RegO and Authorized Product Distributors.

These adhesive warning labels are intended for application as close as possible to the Chek-Lok® once the Chek-Lok® is installed.

The basic information contained on the label is intended for the benefit of the user of the Chek-Lok® and is not intended to be an "all-inclusive" product warning.

This label is printed on a heavy duty material with pressure sensitive adhesive backing. The ultra-violet ink stands up well when exposed to the environment.

DANGER	READ THIS FIRST	WARNING
LP-GAS IS EXTREMELY FLAMMABLE AND EXPLOSIVE		
AVOID SERIOUS INJURY AND PROPERTY DAMAGE. IF YOU SEE, SMELL OR HEAR ESCAPING GAS, EVACUATE AREA IMMEDIATELY! CALL YOUR LOCAL FIRE DEPARTMENT! DO NOT ATTEMPT TO REPAIR. DO NOT STORE IN BUILDING OR ENCLOSED AREA. DO NOT USE ON HOT AIR BALLOONS OR AIRCRAFT.		
<p>Make sure you are thoroughly trained before you attempt any valve installation, maintenance or repair. Improper conditions or procedures can cause accidents resulting in property damage and personal injury.</p> <p>Become thoroughly familiar with NFPA Safety Pamphlet 506 "LP-Gas Regulator and Valve Inspections & Maintenance" and RegO Safety Warnings "LP-Gas Cylinder Valves", "LP-Gas Excess Flow Valves", and "LP-Gas Filler and Hose End Filling Valves" found in the cylinder valve, excess flow valve, and filler valve sections of the L-500 & L-102 Catalogs. Follow their recommendations.</p> <p>Know and understand NFPA Pamphlet 58 "Liquefied Petroleum Gas Code", which is the law in many states. This publication is available from NFPA, Batterymarch Park, Quincy, MA 02269. Following its requirements is essential in the safe use of LP-Gas. Section 4.4 states: "Persons who transfer liquid LP-Gas, who are employed to transport LP-Gas, or whose primary duties fall within the scope of this code shall be trained in proper handling procedures. Refresher training shall be provided at least every three years and shall be documented."</p> <p>Make sure this valve is the proper one for this installation. Avoid misusing LP-Gas equipment.</p> <p>Apply thread joint compound compatible with LP-Gas on valve external threads only. Make sure compound never comes into contact with other parts of the valve.</p> <p>Install valves by applying force to wrenching flats only.</p> <p>Tighten pipe threads approximately 1 to 1 1/2 turns beyond the hand-tight insertion point using a wrench which avoids damage to other valve parts.</p> <p>Check for damage and proper operation after valve installation. Check that the valve is clean and free of foreign material.</p> <p>Check container-valve connection with a non-corrosive leak detection solution before filling with LP-Gas.</p> <p>Purge container before filling with LP-Gas (refer to the RegO LP-Gas Serviceman's Manual for recommended procedure).</p> <p>Test excess flow check valve for proper operation before placing in service. See NPGA Bulletin 113 for recommended procedure.</p> <p>Check outlet connection make-up for leaks with a non-corrosive leak detection solution when placing in service.</p> <p>RegO Filler Valves: To prevent damage to the internal checks when it is necessary to utilize an unloading adapter, use ONLY RegO 3119A, 3120 and 3121 Unloading Adapters with RegO Filler Valves. Carefully follow the instructions supplied with these unloading adapters.</p> <p>If container is not being placed into service at the present time, insert plug or cap onto the outlet connection.</p> <p>In selecting a label for posting at the installation site, consider RegO part number 901-400 or 903-400 along with your own, NPGA's and others.</p> <p>Remember to instruct the owner/user/customer in safety matters concerning LP-Gas and this equipment. See RegO Safety Warnings "LP-Gas Cylinder Valves", "LP-Gas Excess Flow Valves", and "LP-Gas Filler and Hose End Filling Valves" found in the cylinder valve, excess flow valve, and filler valve sections of the L-500 & L-102 Catalogs.</p>		
<p>RegO requests that this information be forwarded to your customers. Additional copies are available from RegO and your authorized RegO Distributor.</p> <p>REGO Elon, N.C. 27244 U.S.A. Phone (336) 449-7707 Fax (336) 449-6594 www.regoproducts.com</p>		

Part Number	Description
7572-400	Adhesive Warning Label

DANGER	WARNING
LP-GAS IS EXTREMELY FLAMMABLE AND EXPLOSIVE	
AVOID SERIOUS INJURY AND PROPERTY DAMAGE. IF YOU SEE, SMELL, OR HEAR ESCAPING GAS, EVACUATE AREA IMMEDIATELY! CALL YOUR LOCAL FIRE DEPARTMENT! DO NOT ATTEMPT TO REPAIR. DO NOT STORE IN BUILDING OR ENCLOSED AREA. DO NOT USE ON HOT AIR BALLOONS OR AIRCRAFT.	
CAUTION!	
Use this CHEK-LOK® connection only for liquid evacuation before moving tank in accordance with NFPA Pamphlet 58, which is the law in many states. This publication is available from NFPA, Batterymarch Park, Quincy, MA 02269. Read and follow RegO product instruction number 7572FC-301.	
DO NOT REMOVE, DEFACE OR OBLITERATE THIS LABEL. DO NOT FILL THIS CONTAINER UNLESS THIS LABEL IS READABLE.	
<p>ADDITIONAL SAFETY INFORMATION IS AVAILABLE FROM</p> <p>REGO Elon, N.C. 27244 U.S.A. Phone (336) 449-7707 Fax (336) 449-6594 www.regoproducts.com</p>	

Section G
Internal Valves and Accessories

G

Limited 10 Year Warranty and Limitation Of Liability

LIMITED 10 YEAR WARRANTY

RegO warrants to the original purchasers the products and repair kits manufactured by it to be free from defects in materials and workmanship under normal use and service for a period of 10 years from the date of manufacture. If within thirty days after buyer's discovery of what buyer believes is a defect, buyer notifies in writing and ships the product to RegO at 100 RegO Drive, Elon, NC 27244, RegO, at its option, and within forty-five days of receipt, will repair, replace F.O.B. point of manufacture, or refund the purchase price of that part or product found by RegO to be defective. Failure of buyer to give such written notice and ship the product within thirty days shall be deemed an absolute and unconditional waiver of any and all claims of buyer arising out of such defect.

This warranty does not extend to any product or part that is not installed and used after installation in accordance with RegO's printed instructions, all applicable state and local regulations, and all applicable national standards, such as those promulgated by NFPA, DOT and ANSI. This warranty does not extend to any product or part that has been damaged by accident, misuse, abuse, failure to maintain, or neglect, nor does it extend to any product or part which has been modified, altered, disassembled, or repaired in the field. This warranty does not cover any cosmetic issues, such as scratches, dents, marring, fading of colors or discoloration.

Except as expressly set forth above, and subject to the limitation of liability below, RegO MAKES NO OTHER WARRANTY, EXPRESS OR IMPLIED, INCLUDING, BUT NOT LIMITED TO, THE IMPLIED WARRANTIES OF MERCHANTABILITY AND FITNESS FOR A PARTICULAR PURPOSE, with respect to its products and parts, whether used alone or in combination with others. RegO disclaims all warranties not stated herein.

LIMITATION OF LIABILITY

RegO's total liability for any and all losses and damages arising out of any cause whatsoever shall in no event exceed the purchase price of the products or parts in respect of which such cause arises, whether such cause be based on theories of contract, negligence, strict liability, tort or otherwise.

RegO shall not be liable for incidental, consequential or punitive damages or other losses. RegO shall not be liable for, and buyer assumes any liability for, all personal injury and property damage connected with the handling, transportation, possession, further manufacture, other use or resale of products, whether used alone or in combination with any other products or materials.

From time to time buyers might call to ask RegO for technical advice based upon limited facts disclosed to RegO. If RegO furnishes technical advice to buyer, whether or not at buyer's request, with respect to application, further manufacture or other use of the products and parts, RegO shall not be liable for such technical advice or any such advice provided to buyer by any third party and buyer assumes all risks of such advice and the results thereof.

NOTE: Some states do not allow the exclusion or limitation of incidental, consequential or punitive damages, so the above limitation or exclusion may not apply to you. The warranty gives you specific legal rights, and you may have other rights that vary from State to State. The portions of this limited warranty and limitation of liability shall be considered severable and all portions which are not disallowed by applicable law shall remain in full force and effect.

WARNING

All RegO products are mechanical devices that will eventually become inoperative due to wear, corrosion and aging of components made of material such as rubber, etc. The environment and conditions of use will determine the safe service life of these products. Periodic inspection and maintenance are essential to avoid serious injury and property damage.

Many RegO products are manufactured components which are incorporated by others on or in other products or systems used for storage, transport, transfer and otherwise for use of toxic, flammable and dangerous liquids and gases. Such substances must be handled by experienced and trained personnel only, using accepted governmental and industrial safety procedures.

NOTICE TO USERS OF PRODUCTS

The Limited Warranty stated above is a factory warranty to the first purchasers of RegO products. Since most users have purchased these products from RegO distributors, the user must within thirty (30) days after the user's discovery of what user believes is a defect, notify in writing and return the product to the distributor from whom he purchased the product/part. The distributor may or may not at the distributor's option choose to submit the product/parts to RegO, pursuant to this Limited Warranty. Failure by buyer to give such written notice within thirty (30) days shall be deemed an absolute and unconditional waiver of buyer's claim for such defects. Acceptance of any alleged defective product/parts by RegO's distributor for replacement or repairs under the terms of RegO's Limited Warranty in no way determines RegO's obligations under this Limited Warranty.

Because of a policy of continuous product improvement, RegO reserves the right to change designs, materials or specifications without notice.

Foreword

This catalog describes a complete line of equipment available from RegO® for use with Liquid Propane (LP)-Gas and anhydrous ammonia (NH₃). The following points are important to know for proper use of the catalog:

1. Illustrations and drawings of individual products are representative of “product groups” and all products within a product group are similar in construction.
2. Materials used for construction of products in this catalog are suitable for rated service pressure at temperatures of -40°F to +165°F, unless otherwise specified.
3. Products in this catalog are only intended for use in LP-Gas and/or anhydrous ammonia service as follows.
 - a. “A” or “AA” prefix — Products with this prefix are suitable for NH₃ service (i.e., contain no brass parts).
 - b. “AA” prefix on relief valves — These valves are NOT suitable for use with LP-Gas service. These are of partial aluminum materials and are listed by Underwriters Laboratories (UL) for NH₃ service only.
 - c. All other products including “A” prefix are suitable for use with LP-Gas & NH₃ service.
 - d. “SS” prefix—Hydrostatic relief valve with this prefix are suitable for NH₃ and LP-Gas service (i.e., they have stainless steel materials).
4. We manufacture valves and adapters designed to be used on LP-Gas and Anhydrous Ammonia systems, we do not design systems or consult in system design. For this type of information consult a professional Engineer.

Caution

Do not use any product contained in this catalog with any service commodity other than LP-Gas or NH₃. If you have a need for use of another application, contact RegO, 100 RegO Drive, Elon, NC 27244, (336) 449-7707 ecii@regoproducts.com before proceeding.

Proper application, installation and maintenance of products in this catalog are essential. Users of these products should obtain further information if there are any doubts or questions.

Warning

All RegO products are mechanical devices that will eventually become inoperative due to wear, corrosion and aging of components made of materials such as rubber. The environment and conditions of use will determine the safe service life of these products. Periodic inspection and maintenance are essential to avoid serious injury and property damage.

Many RegO products are manufactured for storage, transport, transfer and use of toxic flammable and dangerous liquids and gases. Such substances should be handled by experienced and trained personnel only, using accepted governmental and industrial safety procedures. Never vent LP-Gas near any possible source of ignition.

Notice

Installation, usage, and maintenance of all RegO products must be in compliance with all RegO instructions as well as requirements and provisions of NFPA #54, NFPA#58, DOT, ANSI, and all applicable federal, state, provincial and local standards, codes, regulations, and laws.

Inspection and maintenance on a periodic basis is essential. Installation and maintenance should be performed only by qualified personnel.

Be sure all instructions are read and understood before installation, operation and service.

Filters

RegO LP-Gas equipment is designed to operate in a system free from contamination. A variety of in-line filters are commercially available to the LP-Gas industry for installation in domestic systems.

The use of an in-line filter should be considered when other system components may be unclean and the system contaminated by rust, scale, dirt, debris or other foreign material.



Purpose

In its continuing quest for safety, RegO publishes a series of bulletins explaining the hazards associated with the use, misuse, and aging of LP-Gas valves and regulators. It is hoped that these factual bulletins will make clear to LP-Gas dealer managers and service personnel, that the utmost care and attention must be used in the installation, inspection, and maintenance of these products, or problems could occur which would result in injuries and property damage.

The National Fire Protection Association NFPA 58 Liquefied Petroleum Gas Code - 2017 Edition states in Section 4.4 Qualification of Personnel; "Persons whose duties fall within the scope of this code shall be provided with training that is consistent with the scope of their job activities and that includes proper handling and emergency response procedures... Refresher training shall be provided at least every 3 years, initial and subsequent training shall be documented". These "RegO Safety Warnings" may be useful in training new employees and reminding older employees of hazards that can occur. It is recommended that all employees complete the Propane Education Research Council's Certified Employee Training Program.'

Nature of Warnings

It is recognized that warnings should be as brief as possible, but the factors involved in internal valve and excess flow valve failures to perform are not simple. They need to be fully understood. If there is a simple warning, it would be:

Make sure that the internal valve's excess flow feature really closes when the flow exceeds rated closing flow, and that the valve will shut-off.

This bulletin is not intended to be an exhaustive treatment of internal valves, and certainly does not cover all safety practices that should be followed in installation, operation and maintenance of LP-Gas systems, which include internal valves.

Internal valves must be closed on Cargo Vehicles when traveling on public roads and highways. The valve should only be open when pumping. Per MC 330 or 331, internal valves must also be equipped with remote closure system when used on transports or bobtails.

There are two types of internal valves being used on storage tanks, transports and bobtails — spring loaded internal valves and differential pressure internal valves. They both provide positive shut-off when product is not being withdrawn and may include excess flow protection for the system during transfer operations.

Spring Loaded Internal Valves

Spring loaded internal valves are manually opened by levers, by means of fuse linked cable mechanisms or pneumatic or hydraulic actuators. They incorporate an excess flow feature that will close the valve when the flow through the valve exceeds its rate of flow. These valves should never be locked open by means of wires, chains, pegs or other devices.

Testing

Testing should be completed on a periodic basis.

1. To check operation of a spring loaded valve, activate the remote control to close the valve while unit is pumping. If the meter indicator flow continues, the valve should be repaired immediately.

2. Testing excess flow feature.

The National Propane Gas Association Safety Bulletin #113-78 states: "In order to test an excess flow valve in a piping system, the flow through the valve must be made to exceed the valve's closing rating."

This testing should only be attempted by trained personnel familiar with the process. If no one at the facility has experience in proper testing, outside expert help should be obtained.

The exact procedure used may vary with the installation, advisability of gas discharge and availability of equipment.

In general, most testing makes use of the fact that the excess flow valves are "surge sensitive" and will close quicker under a sudden flow surge than under steady flow. A sufficient surge can often be created by using a quick open/close valve to control sudden, momentary flow into a tank or piping section containing very low pressure. An audible click from the excess flow valve (and corresponding stoppage of flow) indicates its closure.

A test involving venting gas to the atmosphere is hazardous and may be impractical, or illegal.

Any test of any excess flow valve will not prove that the valve will close in an emergency situation, due to reasons cited before. This test will only check the valves condition, and the flow rate sizing for those test conditions.

3. Tight Shut-Off — A test should be made to ensure the internal valve will give a gas tight seal when the valve is in the closed position. This will require removal of all product downstream from the internal valve, to ensure the valve will give 100% seal when in the closed position. If the internal valve does not give 100% seal the valve should be repaired immediately.

Pressure Differential Internal Valves (Flomatics®)

Pressure differential valves (Flomatics®) open by pump pressure and close when the pump stops. These valves must never be locked open by means of wires, chains, pegs or other devices.

Testing

Testing should be completed on a periodic basis.

1. To check operation of a differential pressure internal valve activate the remote control shut-off valve while the unit is pumping. If the meter indicates that flow continues the valve should be repaired immediately.

2. Since the differential pressure internal valve requires at least 18 psi to open and 8 psi over container pressure to keep open, a test may be performed to check for closure. With the PTO disengaged, connect delivery hose to a container with very low pressure. Then with hose end valve open, engage PTO. The internal valve should remain closed, no flow should be detected through the meter. If flow continues through the meter the valve should be repaired immediately.

3. Tight Shut-Off — A test should be made to ensure the internal valve will give a gas tight seal when the valve is in the closed position. First ensure the pump prime valve is closed by turning clockwise until it seats. Then with the valve closed (PTO disengaged) the product downstream from the internal valve will have to be safely removed. If the internal valve does not give 100% seal, the valve should be repaired immediately.

General Warning

All RegO Products are mechanical devices that will eventually become inoperative due to wear, contaminants, corrosion and aging of components made of materials such as metal and rubber.

The environment and conditions of use will determine the safe service life of these products. Periodic testing at least once a year when tank pressures are low and maintenance, as required, are essential.

Because RegO products have a long and proven record of quality and service, LP-Gas dealers may forget the hazards that can occur because an excess flow valve is used beyond its safe service life. Life of an excess flow valve is determined by the environment in which it "lives". The LP-Gas dealer knows better than anyone what this environment is.

NOTE: There is a developing trend in state legislation and in proposed national legislation to make the owners of products responsible for replacing products before they reach the end of their safe useful life. LP-Gas dealers should be aware of legislation which could effect them.



G

Manual Internal Valves

A3200 Series

General Information

Manual Internal Valves are designed for a variety of uses in LP-Gas and anhydrous ammonia service. In addition, accessories allow most of them to be actuated manually, by cable or with air.

Installation, usage and maintenance of this product must be in compliance with all RegO instructions, as well as requirements and provisions of NFPA # 58, DOT, ANSI, and all applicable federal, state, provincial, and local standards, codes, regulations and laws.

How The Valves Work

Refer to the drawings. View "A" shows the valve held closed without leakage by tank pressure and the valve's closing spring. Actuation of the operating handle alone does not open the valve, it only allows pressure to equalize between the inlet and outlet of the valve by rapid bleeding of the product downstream. This equalized pressure then allows the valve to open via the internal spring.

The valve opens by moving the handle to mid-point, see view "B". This position allows the actuator to put the equalizing portion of the valve stem in the pilot opening, allowing more product to bleed downstream than if the handle was fully open.

In a few seconds, the tank and downstream pressure will be nearly equal. The excess flow spring will push the main poppet to the open position, see view "C", the handle should then be moved to the fully open position.

If at first, the handle is quickly moved to the fully opened position, the pilot valve allows a small amount of bleed downstream, but much less than during rapid bleed (view "B"). This results in a longer pressure equalizing time before the main valve can open.

NOTE: The main poppet will not open until outlet pressure approximates tank pressure!

Once the main poppet is open, flow greater than the excess flow rating, or a sufficient surge in flow, forces the main poppet closed against the excess flow spring, as seen in view "D". The pilot valve in this position is open and allows a small amount of bleed downstream, but much less than during rapid bleed (view "B").

When the operating handle is moved to the closed position, the valve closes and a leak-tight seal is re-established as seen in view "A".

NOTE: To provide excess flow protection, the flow rating of the pump, piping, valves, fittings, and hose on the inlet and outlet sides of the valve must be greater than the flow rating of the valve. Any restrictions that reduce the flow to less than the excess flow valve rating will result in the excess flow valve not operating when required.

Valve Operation and Precautions

1. Valve must be opened before starting pump, and before opening valve on pump outlet.
2. Leave pumping system "wet" to avoid drying of seals and to reduce time involved in opening valve. Drain piping only when required by codes or safe operating practices.
3. When piping is dry or at lower pressure than the tank, open valve half-way for a few seconds to allow line pressure to equalize before fully opening the valve handle. The main poppet may not open immediately if the handle is placed in the open position too quickly.
4. Flow surges may close the built-in excess flow valve and should be avoided. If the valve slams shut, immediately stop the pump, close the nearest downstream valve, and move handle to midpoint position to equalize pressure until valve reopens with a click, then restart pump and open downstream valve slowly.

These valves must remain in the closed position except during product transfer. A line break downstream of the pump may fail to actuate the excess flow valve as the pump may limit flow. If break occurs in the system, or the excess flow closes, immediately shut down the system.

Inspection and maintenance on a periodic basis is essential. Installation and maintenance must be performed only by qualified personnel.

Be sure all instructions are read and understood before installation and operation of these valves.

5. Always keep valve closed except during product transfer.

6. Completely open all valves during pumping. Partially closed or throttle type valves may prevent excess flow valve from closing when required, even in a properly designed piping system.

7. All personnel must be aware of remote closure locations and their operation in case of emergency. They must also be aware of the equalizing opening through which bleeding can occur after the excess flow valve closes. If this bleed is not stopped by closing a downstream valve, a hazard may occur.

8. Never, under any circumstances, permanently wire open the operating handle of the internal valve.

Cable Control System

The cable control system employed must meet the requirements and be in accordance with the provisions of NFPA #58, DOT, ANSI, and all applicable federal, state, provincial and local codes.

Troubleshooting

1. Internal Valve Will Not Open. Causes may be excess leakage downstream, pump engaged too quickly, excessive wear of valve, or ice freezing of poppet.

When there is excessive volume downstream, a greater amount of time is required to equalize tank and downstream pressure.

To determine if the pilot seat is opening, install a pressure gauge downstream of valve outlet, open any hand valves between valve and pressure gauge, and open valve. Pilot seat is not opening if pressure does not build up to tank pressure. Perform this test with pump off. A broken internal part may cause pilot seat not to open.

If operating handle rotates past the full open position, there is internal malfunctioning, and the valve must be disassembled and repaired.

2. Premature Valve Closure.

First, check to see that operating lever is properly connected and fully opens valve. Premature closure may also be a result of engaging pump too quickly, sudden line surges, an underrated excess flow spring or an obstructed inlet port.

3. Valve Will Not Close.

Usually a result of faulty or sticking actuator. First, check the actuator to see that it works freely by disconnecting it from valve handle and cycling it several times. Also, operate valve handle manually. If it sticks in the open position, replace the packing and bushings. This should free the operating mechanism providing the valve has no internal damage.

4. Low Flow Capacity

Downstream piping may be too small and/or long, screen or strainer may be plugged, possible restriction downstream, or a bypass valve stuck in the open position are causes of low flow. Also, the bypass valve may be set too low and prematurely opening. Check for high differential pressure across the bypass valve. If bypass valve is open, the differential across the valve should not exceed 5 to 6 psig.

Maintenance

Potential problems may be eliminated with preventive internal valve maintenance. Perform the following steps once a month:

1. Check to see that the operating lever moves freely and smoothly. There should be no leakage around the lower stem or seal housing. Leakage requires replacement of the seal housing packing. A sticking lever indicates trapped foreign material or mechanism wear.
2. Check both seat discs for tight closure. Close valve and exhaust downstream pressure. Be sure piping is warmed to an ambient temperature. Close the first downstream valve and note pressure buildup between the closed valves with a pressure gauge. If leakage occurs, replace both seat discs.

3. Inspect, clean and oil all operating controls. Check controls to see that they open fully, but do not overtravel the valve operating lever. See that they work freely to close the valve. Worn parts should be replaced.

4. Remove valve if the tank is to be steam cleaned. Heat may damage the valve's seals.

5. Valve is not designed for water service. After tank is hydrostatically tested, immediately remove all water and allow tank to thoroughly dry out before installing valve.

- A3209D Series, 1¼" Straight
- A3209DT Series, 1¼" Tee Body
- A3211D Series 1½" Straight
- A3212R Series, 2" Straight
- A3212RT Series 2" Tee Body
- A3213D Series, 3" Straight
- A3213DT Series 3" Tee Body

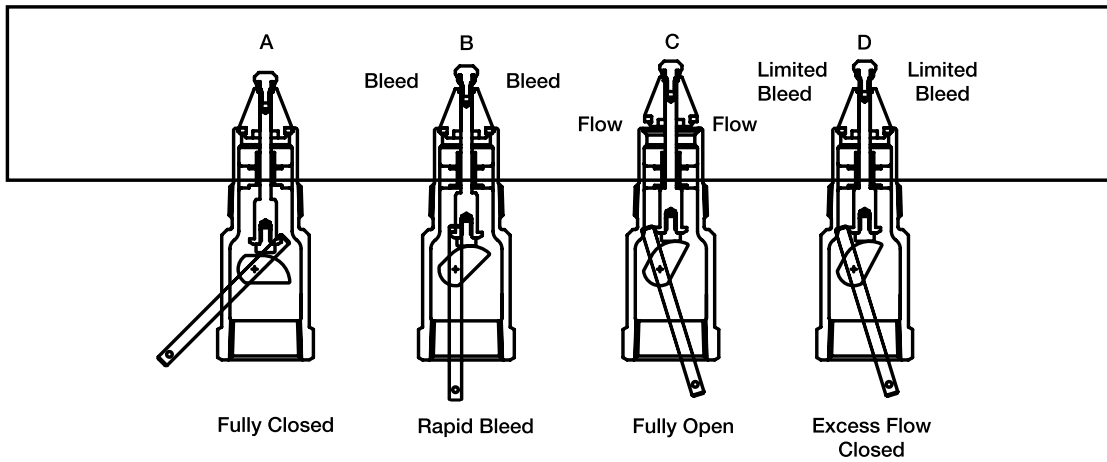

A3219FA Series, 4" Flanged

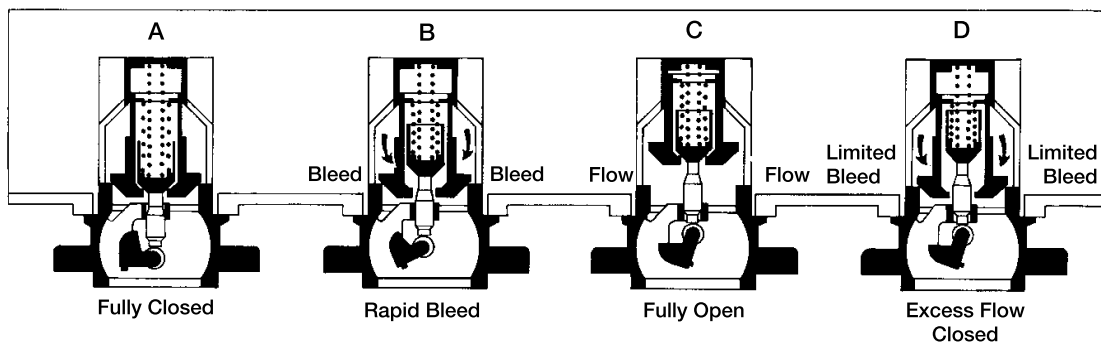

1/4" Threaded Internal Valve for Small Capacity Pumping Systems and Bobtail Vapor Equalization A3209D & A3209DT Series

Application

Designed primarily for use with LP-Gas and anhydrous ammonia as a main valve on small capacity pumping systems, NH3 nurse tanks and in-line installations. It may also be installed in the vapor equalizing opening on bobtail delivery trucks. Installation is quick and easy, and it fits in both full and half couplings, as well as, in-line applications. The valve may be actuated manually by hand or cable.

Features

- Valve is compact, with one piece body construction.
- Spring loaded V-packing with heavy duty wiper ring on operating shaft for dependable leak-free construction.
- Nylon bearing supported operating shaft provides smooth, easy operation.
- Simple operating lever allows for easy connection of cable controls.
- Built in excess flow valve
- Return spring forces the valve to the closed position when the lever is released.
- All critical operating components are located in the valve body and inside the container coupling for maximum protection against damage.
- Midway stem position allows for quick pressure equalization.
- Equipped with 212° F, UL listed fuse link for thermal protection.



A3209DT



A3209D

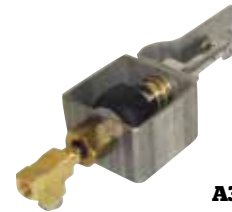
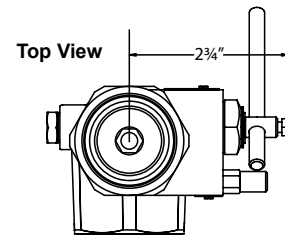

A3209PAF



A3209PA



A3209TL

Materials

Body	Ductile Iron
Operating Lever.....	Cadmium Plated Carbon Steel
Stem	Stainless Steel
Springs	Stainless Steel
Seat Disc	Resilient Synthetic Rubber
Shaft Bearing.....	Nylon

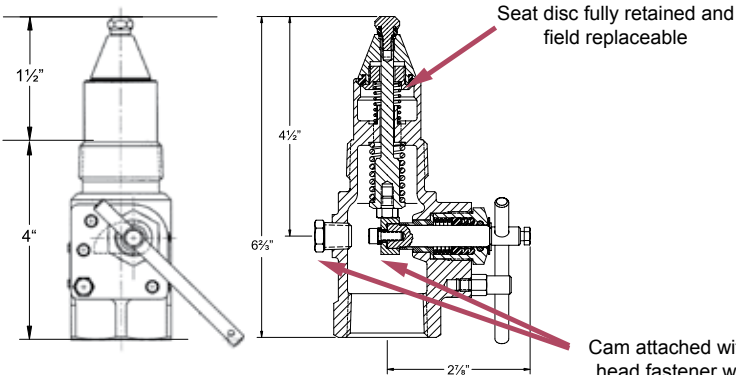

Cam attached with Allen head fastener which is accessed from the 1/4" pipe plug on side of the body

Ordering Information

Part Number	Inlet Connection M. NPT	Outlet Connection F. NPT	Closing Flow		LP-Gas Vapor Capacity** (SCFH/Propane)		Accessories	
			LP-Gas	NH3	25 PSIG	100 PSIG	Thermal Latch	Pneumatic Actuators
A3209D050	1/4"	1/4"	50	45	13,300	22,900	A3209TL	A3209PA A3209PAF
A3209D080	1/4"	1/4"	80	72	15,700	26,700		
A3209DT050*	1/4"	1/4"	50	45	13,300	22,900		
A3209DT080*	1/4"	1/4"	80	72	15,700	26,700		

* T-Body Design

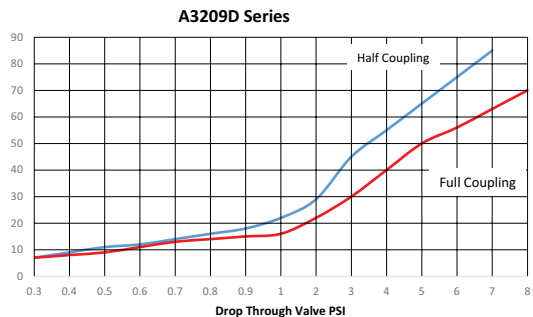

1/4" Threaded Internal Valve with Electric Actuator for Small Capacity Pumping Systems and Bobtail Vapor Equalization A3209E Series

Application

Designed primarily for use with LP-Gas as a main valve on small capacity pumping systems such as auto gas dispensers. It may also be installed in the vapor equalizing opening on bobtail delivery trucks. Installation is quick and easy, and it fits in both full and half couplings, as well as, in-line applications. The valve comes fully assembled with the electric actuator, ready to install.

Features

- Valve is compact, with one piece body construction.
- Spring loaded V-packing with heavy duty wiper ring on operating shaft for dependable leak-free construction.
- Nylon bearing supported operating shaft provides smooth, easy operation.
- Simple operating lever allows for easy connection of cable controls.
- Built in excess flow valve
- Return spring forces the valve to the closed position when the lever is released.
- All critical operating components are located in the valve body and inside the container coupling for maximum protection against damage.
- Midway stem position allows for quick pressure equalization.
- Equipped with 212° F, UL listed fuse link for thermal protection.



A3209E

Materials

Body Ductile Iron
 Operating Lever..... Cadmium Plated Carbon Steel
 Stem Stainless Steel
 Springs Stainless Steel
 Seat Disc Resilient Synthetic Rubber
 Shaft Bearing..... Nylon

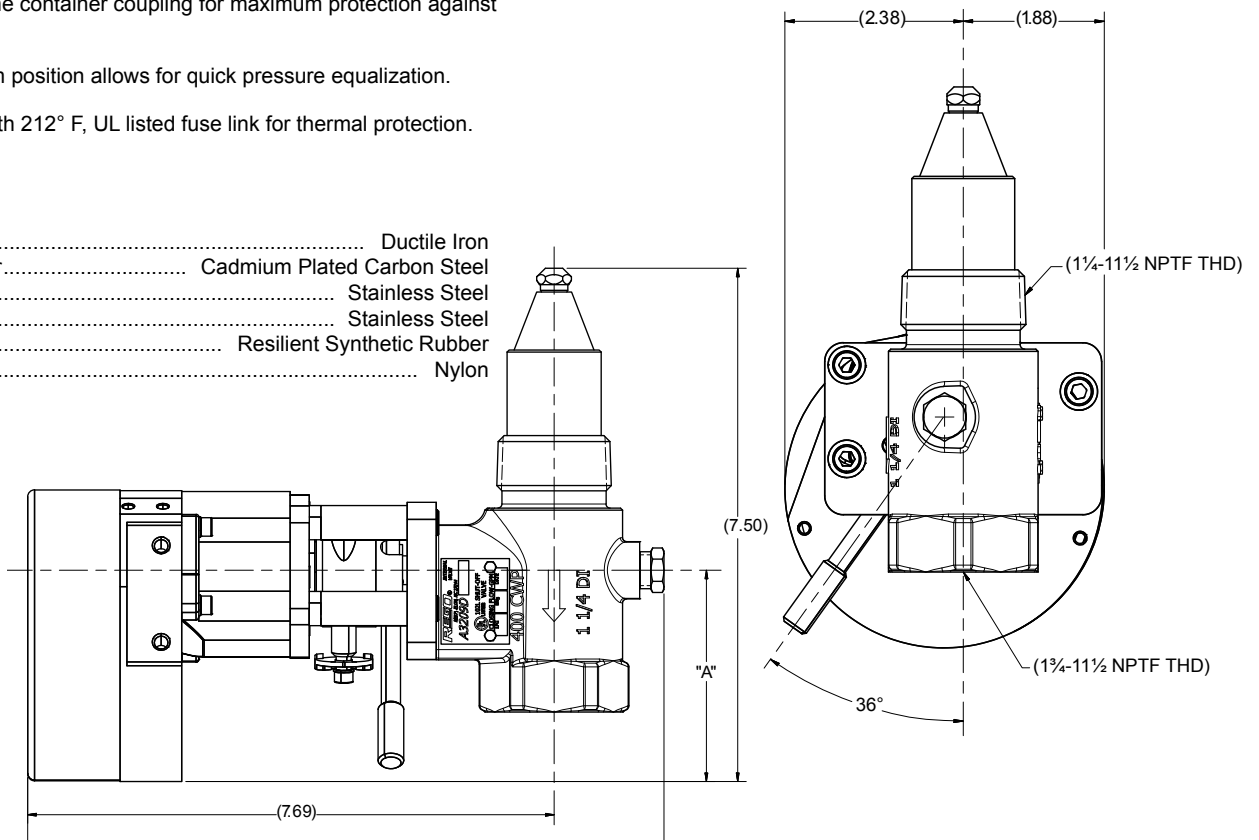

Ordering Information

Part Number	Inlet Connection M. NPT	Outlet Connection F. NPT	Voltages	Closing Flow		LP-Gas Vapor Capacity** (SCFH/ Propane)	
				LP-Gas	NH3	25 PSIG	100 PSIG
EA3209D050	1/4"	1/4"	12/24 VDC	50	45	13,300	22,900
EA3209D080	1/4"	1/4"		80	72	15,700	26,700
EA3209DT050*	1/4"	1/4"		50	45	13,300	22,900
EA3209DT080*	1/4"	1/4"		80	72	15,700	26,700

* T-Body Design

**Data for full flow in half coupling.

Straight Through 1½” Internal Valve A3211D Series

Application

Designed primarily for use with LP-Gas and anhydrous ammonia as a main valve on pumping systems, and in-line installations. Installation is quick and easy and it fits in both full and half couplings, as well as, in-line applications. The valve may be opened manually by hand or pneumatic actuator.

Features

- Valve is compact, with one piece body construction.
- Spring loaded V-packing with heavy duty wiper ring on operating shaft for dependable leak-free construction.
- Nylon bearing supported operating shaft provides smooth, easy operation.
- Simple operating lever allows for easy connection of cable controls.
- Built in excess flow valve
- Return spring forces the valve to the closed position when the lever is released.
- All critical operating components are located in the valve body and inside the container coupling for maximum protection against damage.
- Midway stem position allows for quick pressure equalization.
- Equipped with 212° F, UL listed fuse link for thermal protection.



A3211D

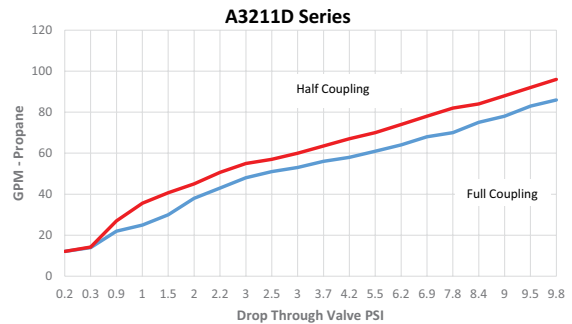

Materials

Body Ductile Iron
 Operating Lever..... Cadmium Plated Carbon Steel
 Stem Stainless Steel
 Springs Stainless Steel
 Shaft Bearing..... Nylon
 Seat Disc Synthetic Rubber

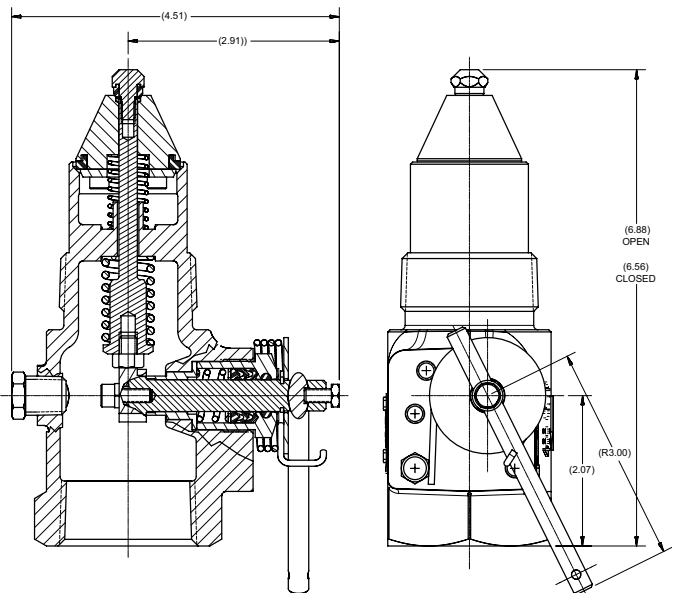

Ordering Information

Part Number	Inlet M.NPT	Outlet F.NPT	Closing Flow GPM				LP-Gas Vapor Capacity (SCFH/Propane)		Accessories	
			Half Coupling		Full Coupling		25 PSIG Inlet	100 PSIG Inlet	Thermal Latch	Pneumatic Actuator
			LP-Gas	NH ₃	LP-Gas	NH ₃				
A3211D080	1½"	1½"	80	72	63	67	15,700	26,700	A3209TL	A3209PAF
A3211D110	1½"	1½"	110	99	84	76	N/A	N/A		

3" Flanged Internal Valves for Bobtail Delivery Trucks, Transports and Large Stationary Storage Containers A3217A & A3217DA

Application

Designed primarily for LP-Gas and anhydrous ammonia filling and/or withdrawal on MC331 bobtail delivery trucks, transports and stationary storage tanks with flanged pumps or piping. Installation is quick and easy, and the valve may be operated manually by cable or pneumatically. Lever available on right or left side to allow for installation without the use of an extra pulley.

Features

Provides More Efficient Operation

- Flow passages designed to allow substantially higher flow without cavitation or loss of efficiency--saving time and money.
- Simple operating lever facilitates easy adaptation of all cable controls.
- Lever available on right or left side to allow for installation without the use of an extra pulley.
- Nylon bearing supported operating shaft provides smooth, easy operation.

Less Frequent-Easier Maintenance

- Stainless steel screws resist rusting and are easily removed during valve disassembly.
- Heavy duty rod wiper helps minimize dirt and foreign material from entering operating shaft and hampering operation.

Durable Construction

- Cadmium plating helps resist corrosion during storage and use.
- All ferrous materials with a temperature range of -40° F. to +165° F. and a pressure rating of 400 psi.
- Sturdy retaining ring secures operating cam to provide for more durable, slack-free operation.
- Built-in excess flow valve.
- Specify RegO Internal Valves on your next new tank or when your truck is rebuilt.



A3217AR

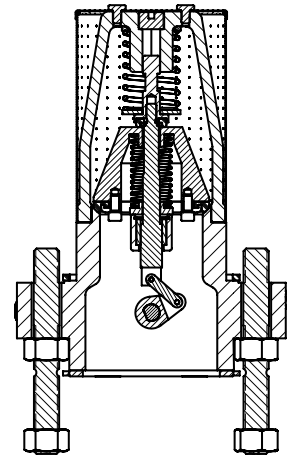

Ordering Information

Part Number	Operating Lever Position	Inlet Connection	Outlet Connection	Closing Flow GPM		Accessories	
				LP-Gas	NH3	Pneumatic Actuator	
						Right Operation	Left Operation
Single Flange							
A3217AR160	A3217AL160	3" 300# ANSI RF Modified Flange*	3" 300# ANSI RF Flange	160	145	A3217ARPA A3217RA	A3217ALPA A3217LA
A3217AR210	A3217AL210			210	190		
A3217AR260	A3217AL260			260	236		
A3217AR410	A3217AL410			410	372		
A3217AR510	A3217AL510			510	459		
Double Flange							
A3217DAR160	A3217DAL160	3" 300# ANSI RF Modified Flange*	3" 300# ANSI RF Flange	160	145	A3217ARPA A3217RA	A3217ALPA A3217LA
A3217DAR210	A3217DAL210			210	190		
A3217DAR260	A3217DAL260			260	236		
A3217DAR410	A3217DAL410			410	372		
A3217DAR510	A3217DAL510			510	459		

* Valve supplied with 16 nuts and 8 studs for mounting.

**Modified bore=4 1/2" diameter with 5 1/2" diameter raised face.

3" Flanged Internal Valves for Bobtail Delivery Trucks, Transports, and Large Stationary Storage Tanks

A3217ARPA and A3217ALPA Pneumatic Actuators

These Pneumatic Actuators are designed specifically for use with the A3217 Series 3" Internal Valves. The diaphragm design provides a convenient means of opening and closing the valve from a remote location, using either air or nitrogen.



Features

- Diaphragm type—no seals to leak.
- Easily installed on internal valve "in-line."
- Utilizes standard air brake chamber with proven performance over many years of heavy-duty truck/trailer applications.
- Compatible with existing air interlock systems.
- Operates with pressures of 50-150 psig.
- Thermal Fuse installed complies with DOT thermal protection requirements.

Materials

Body and Valve Cage	Cadmium Plated Ductile Iron
Seat	Nickel Chrome Plated Steel
Strainer	Stainless Steel
Shaft	Stainless Steel
Pilot Valve Stem	Stainless Steel
Springs	Stainless Steel
Actuator Cam.....	Stainless Steel
Lever.....	Cadmium Plated Carbon Steel
Seat Disc	Resilient Synthetic Rubber

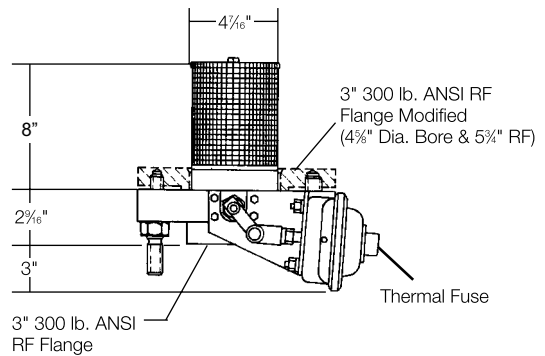
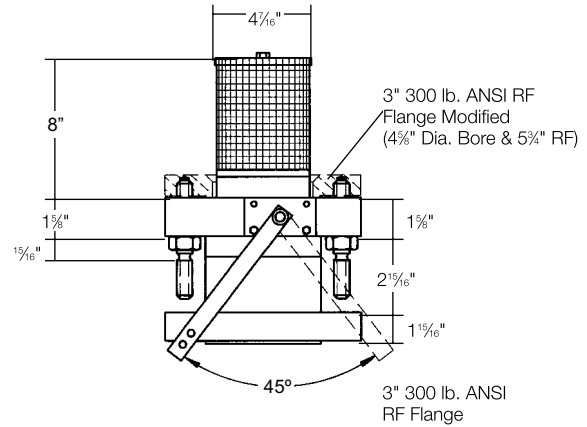

Typical Valve Installation

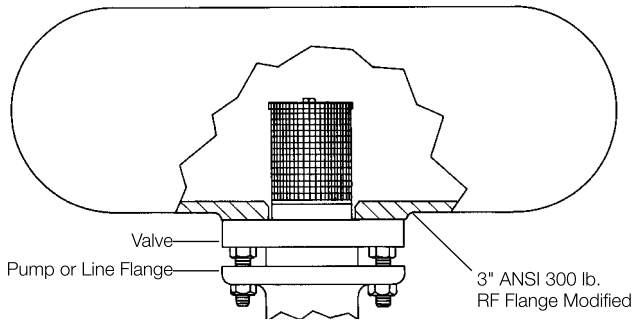

A3217A & FA Series

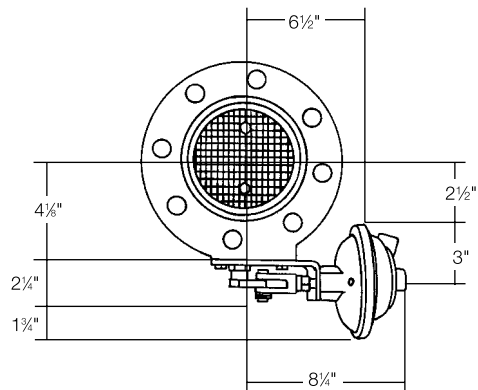
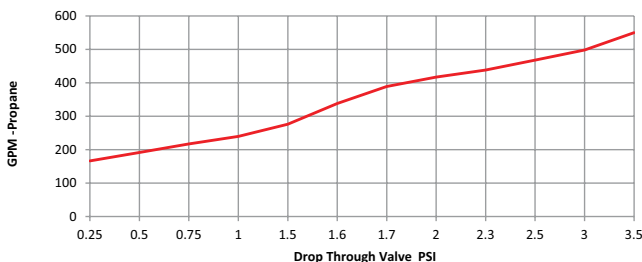

4" Flanged Internal Valve for Transports and Large Stationary Storage Tanks A3219 Series

Application

Designed primarily for LP-Gas and anhydrous ammonia service on MC331 transport pressure vessels and large stationary storage tanks. Installation is quick and easy, and it fits in most existing tank flanges. The valve may be actuated manually or pneumatically.

Use of the A3219RT Remote Thermal Release with this valve is suggested to provide a remote means of mechanical closure along with thermal protection, as required by DOT.

Features

Provides More Efficient Operation

- Flow passages designed to allow higher pumping rates without cavitation or loss of efficiency—saves time and money.
- One piece, stainless steel pilot valve provides more accurate alignment for dependable operation.
- Remote release lever allows cables to run directly to opposite ends of vessel without pulleys or tubing.

Protects Your Pump

- Main disc retaining screws are installed from the top down to help minimize loose screws from entering and damaging the pump.
- Back-up cotter pin is designed to minimize the chance of a loosened actuator nut and washer from entering and damaging the pump.

Less Frequent-Easier Maintenance

- Easily replaceable chrome plated seat insert eliminates need for expensive remachining of valve body when overhauled.
- Stainless steel screws resist rusting and are easily removed during valve disassembly.
- Strainer completely covers the top of the valve to help keep out sediment and foreign material.
- Strainer seats at the top flange of the valve's seat insert, making removal of the valve easier.

Durable Construction

- Cadmium plating helps resist corrosion during storage and use.
- Taper pin lock secures the operating shaft to provide for more precise, trouble-free actuation.
- Built-in excess flow valve and thermal protection.
- Specify RegO Internal Valves on your next new tank body or rebuild.



A3219FA



A3219FPA

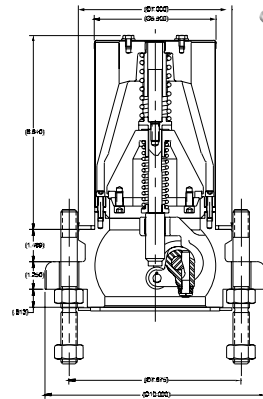

A3219RA

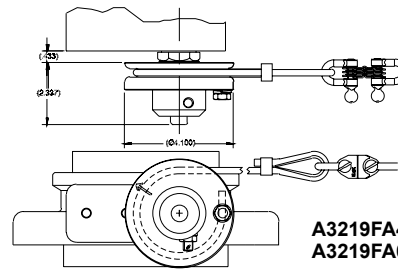

**A3219FA400W
A3219FA600W**

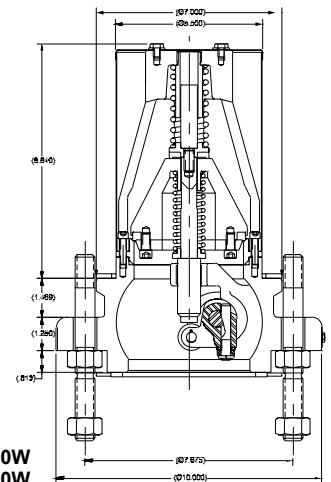

Materials

Body and Valve Cage	Cadmium Plated Ductile Iron
Handle	Cadmium Plated Ductile Iron
Seat	Nickel Chrome Plated Steel
Strainer	Stainless Steel
Stem	Stainless Steel
Pilot Valve Plug	Stainless Steel
Springs	Stainless Steel
Roller Actuator	Cadmium Plated Carbon Steel
Lever Assembly	Cadmium Plated Carbon Steel
Seat Disc	Resilient Synthetic Rubber

Ordering Information

Part Number*	Inlet Connection	Outlet Connection	Closing Flow GPM***		Accessories	
			LP-Gas	NH3	Pneumatic Actuator	Remote Thermal Release
A3219FA400L	4" 300# ANSI RF Modified Flange**	4" 300# ANSI RF Flange	400	360	A3219FPA A3219RA	A3219RT (2)
A3219FA600L			600	540		
A3219FA600W			400	360	-	A3219W
A3219FA400W						

* Valve supplied with 16 nuts and 8 studs for mounting.
 ** Modified bore = 5 7/8" diameter with 7" diameter raised face.
 *** Other closing flows available

4" Flanged Internal Valves for Transports and Large Stationary Storage Tanks

Application

A3219FPA Pneumatic Actuator

The A3219FPA Pneumatic Actuator is designed especially for use with the A3219FA Series Flanged Internal Valves. The diaphragm type A3219FPA provides a convenient means of opening and closing the valve from a remote location, using either air or nitrogen, on LP-Gas and NH3 transport trailers and stationary tanks.

Features

- Diaphragm type—no seals to leak.
- Easily installed on internal valve "in-line."
- Utilizes standard brake actuator with time proven performance in heavy-duty truck/trailer applications.
- Compatible with existing air interlock systems.
- Operate with pressures of 50-150 psig.
- Thermal fuse installed in actuator complies with DOT thermal protection requirements.

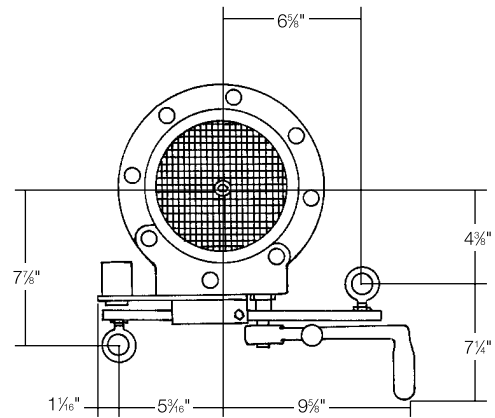
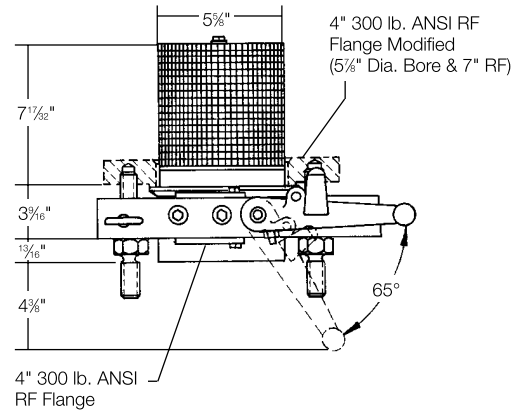

Typical Valve Positioning

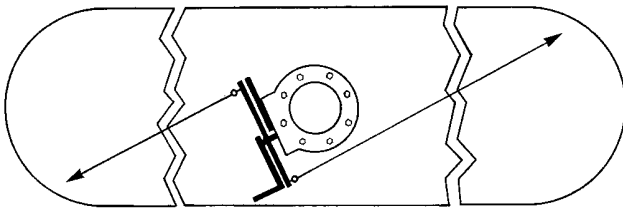

Typical Valve Installation

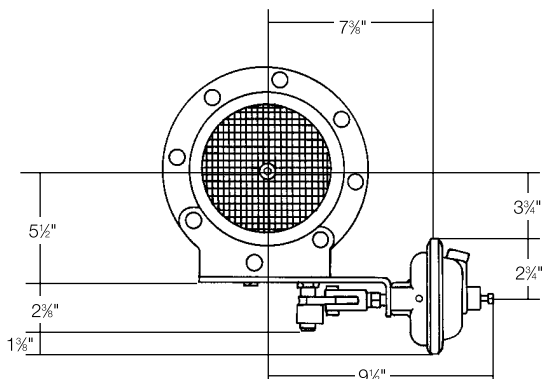
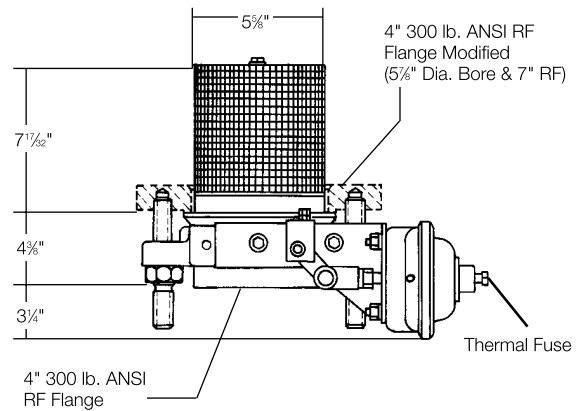
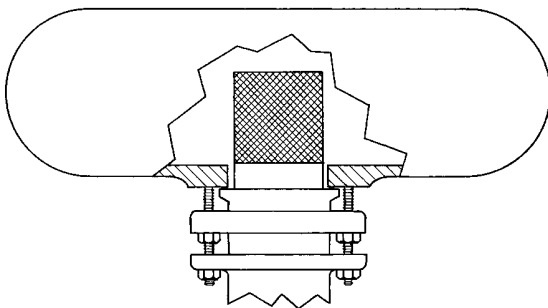

A3219FA600L

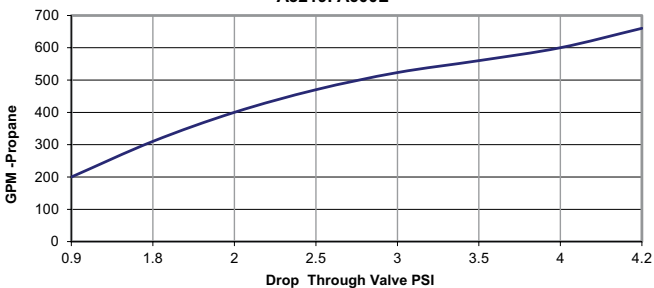

Remote Thermal Release for DOT MC331 Pressure Vessel A3219RT

Application

Designed especially for use with Internal Valves installed in DOT MC331 pressure vessels. The A3219RT provides a remote means of mechanical closure along with thermal protection, as required by DOT MC331.

The A3219RT is connected by cable to the internal valve(s) on the vessel. In the event of extreme heat (over 212° F.), the fuse link will melt, causing the spring to contract and pull the cable. When properly installed the cable will trip the internal valve release lever(s) allowing the connected handle(s) to move to the closed position.

Materials

Body Galvanized Steel
Springs Stainless Steel

Ordering Information

Part Number	For Use With	Release Temperature	Spring Load		Minimum Number Required By MC331
			Fully Extended	After 4" Travel	
A3219RT	Internal Valves	212° F.	≈100 lbs.	≈50 lbs.	2

Typical Mounting Side View

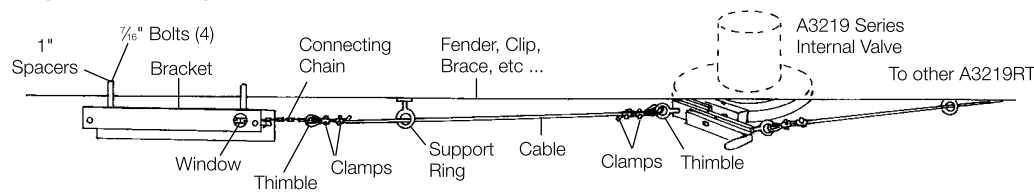

A3219RT

Features

- Meets DOT MC331 requirements.
- Easily installed, rugged formed steel bracket has open bottom to minimize dirt and water build-up.
- Heavy, shouldered pins lock into position.
- Stainless steel spring provides dependable performance with 100 lb. load.
- Heavy-duty chain adapts easily to standard cable and fittings.
- Fuse link has 212° F. release temperature.
- Adapts easily to standard cables and fittings.



Remote Cable Controls for Internal Valves 3200C and 3200L

Application

The 3200C Remote Cable Kit is designed especially for use with the 3200L Remote Operating Lever to operate internal valves from a remote location.

The internal valve is opened by pulling back the remote operation lever and closed by returning the lever to its original position. A remote release is provided to close the internal valve from a different remote location.

Features

- Metal construction provides durability in heavy duty applications.
- Toggle action of operating lever allows for quick closure without extra springs and latches.
- The unique clamping nut and cable clamps provide easy installation.
- Fuse connections allow internal valves to close if connections are exposed to fire.
- Versatile design permits installation on bobtails and stationary tanks at bulk plants.
- Provides necessary remote closure system for bobtails required by DOT regulation on MC330/MC331 tanks and NFPA #58.

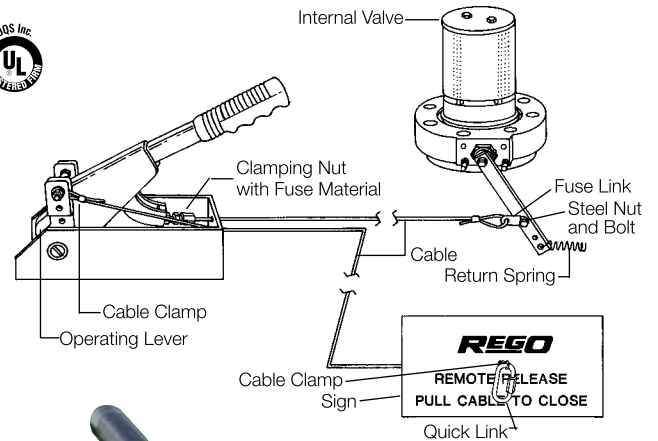

3200L



Ordering Information

Part Number	Description	Contents
3200C	Remote Cable Kit	100 Foot Cable, 6 Cable Clamps, Quick Link, Sign, Fuse Link, Steel Nut and Bolt
3200L	Operating Lever	Lever Assembly

Materials

Body Galvanized Steel
Springs Stainless Steel

Threaded Internal Valves For Bobtail Delivery Trucks, Transports and Stationary Storage Tanks A3213D Series

Application

Designed primarily for use with LP-Gas and anhydrous ammonia for liquid withdrawal; vapor transfer or vapor equalization of bobtail delivery trucks, transports, stationary storage tanks, and in-line installations. The valve may be operated manually by cable or pneumatically.

Features

- May be installed in full and half couplings.
- Nylon bearing supported operating shaft provides smooth, easy operation.
- Simple operating lever facilitates easy adaptation of all cable controls.
- Midway stem position allows for quicker pressure equalization.
- All critical operating components are located in the valve body inside the container coupling for maximum protection against physical damage.
- Built-in excess flow valve.
- Return spring returns the valve to the closed position when the handle is released.
- Specify RegO Internal Valves on your next new tank body or when your tank is rebuilt.
- A3213PA pneumatic actuator provides a convenient means of opening and closing the valve from a remote location, using either air or nitrogen for A3213D service valves.

Materials

Body Ductile Iron
 Operating Lever..... Cadmium Plated Steel
 Stem Stainless Steel
 Springs Stainless Steel
 Seat Disc Resilient Synthetic Rubber
 Shaft Bearing..... Nylon



Seat disc fully retained and field replaceable.

Excess flow spring is independent from return spring operation

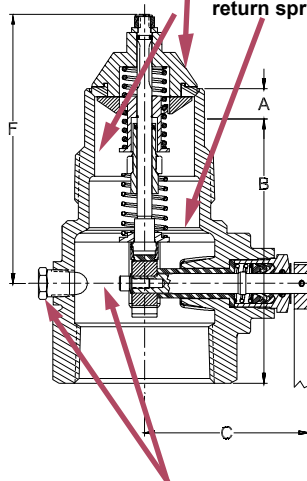

A3213D Series

Cam attached with Allen head fastener which is accessed from the 1/4" pipe plug on side of the body

A3213DT

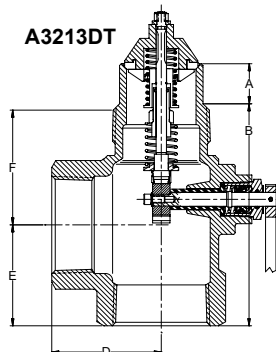

A3213RA



A3213PA



A3213TL

A3213D Series

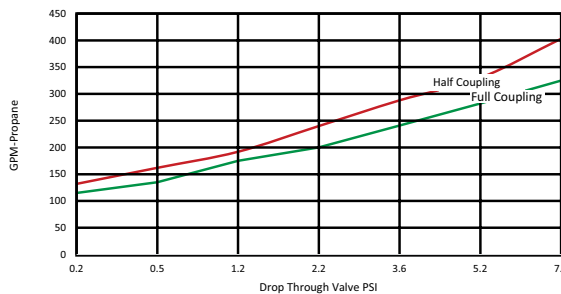

Ordering Information

Part Number	Inlet Connection M.NPT	Outlet Connections F.NPT	Closing Flow Half Coupling (GPM)		Closing Flow Full Coupling (GPM)		Vapor Closing Flow (SCFH)		Accessories		
			LPG	NH ₃	LPG	NH ₃	25 PSIG Inlet	100 PSIG Inlet	Pneumatic Actuator	Rotary Actuator	Thermal Latch
A3213D150	3"	3"	150	135	125	113	26,900	45,900	A3213PA	A3213RA	A3213TL
A3213D200			200	180	160	144	32,300	55,100			
A3213D300			300	270	250	225	50,500	86,500			
A3213D400			400	360	325	293	71,400	121,300			
A3213DT150*			150	135	125	113	26,900	45,900			
A3213DT200*			200	180	160	144	32,300	55,100			
A3213DT300*			300	250	250	225	50,500	86,500			
A3213DT400*			400	325	325	293	71,400	121,300			

* T-body design

Threaded Internal Valves For Bobtail Delivery Trucks, Transports and Stationary Storage Tanks A3212 Series

Application

Designed primarily for use with LP-Gas and anhydrous ammonia for liquid withdrawal; vapor transfer or vapor equalization of bobtail delivery trucks, transports, stationary storage tanks, and in-line installations. The valve may be operated manually by cable or pneumatically.

Features

- May be installed in full and half couplings.
- Nylon bearing supported operating shaft provides smooth, easy operation.
- Simple operating lever facilitates easy adaptation of all cable controls.
- Midway stem position allows for quicker pressure equalization.
- All critical operating components are located in the valve body inside the container coupling for maximum protection against physical damage.
- Built-in excess flow valve.
- Return spring returns the valve to the closed position when the handle is released.
- Specify RegO Internal Valves on your next new tank body or when your tank is rebuilt.
- A3213PA pneumatic actuator provides a convenient means of opening and closing the valve from a remote location, using either air or nitrogen for both the A3212R & A3213A service valves.

Materials

Body Ductile Iron
 Operating Lever..... Cadmium Plated Steel
 Stem Stainless Steel
 Springs Stainless Steel
 Seat Disc Resilient Synthetic Rubber
 Shaft Bearing..... Nylon

A3212R Series

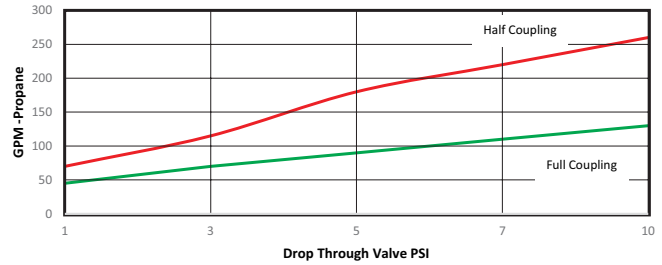

A3212R Series

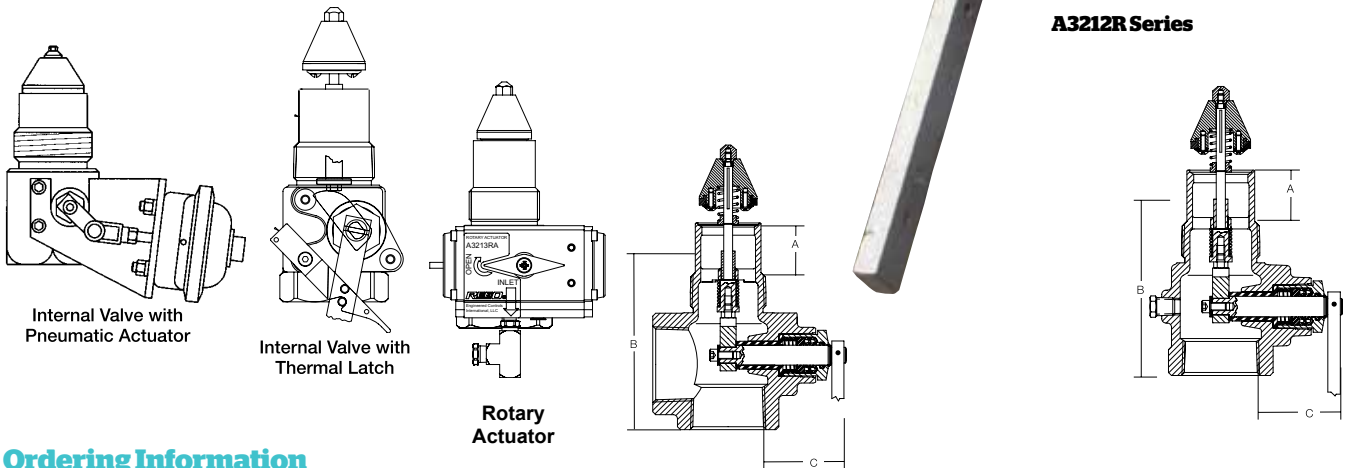

Ordering Information

Part Number	Inlet Connection M. NPT	Outlet Connection F. NPT	Closing Flow (GPM) Half Coupling		Closing Flow (GPM) Full Coupling		A	B	C	Accessories		
			LP-Gas	NH3	LP-Gas	NH3				Thermal Latch	Pneumatic Actuator	Rotary Actuator
A3212R 105	2"	2"	105	95	65	59	1 9/16"	4 11/16"	3 45/64"	A3213TL	*A3213PA	A3212RA
A3212R T105		2" T-body										
A3212R 175		2"	175	158	100	90		4 11/16"				
A3212R T175		2" T-body										
A3212R 250		2"	250	225	130	117		4 11/16"				
A3212R T250		2" T-body										

* For the old A3212A Series please use the A3212PA Pneumatic Actuator

Flomatic® Internal Valves for Bobtail Delivery Trucks, Transports and Large Stationary Storage Tanks A7883FK

Application

Designed primarily for LP-Gas and anhydrous ammonia liquid withdrawal on MC331 bobtail delivery trucks, transports and large stationary storage containers with flanged connections. The valve is fully automatic, opening and closing as the pump is turned on or off.



Features

Fully Automatic

- Operates on pressure differential from the pump to open and close.
- Automatically closes should downstream line rupture causing loss of pump differential pressure required to keep the valve open.
- Problems of improperly sized excess flow valves slugging shut during liquid transfer are eliminated.

Faster Unloading

- Straight through flow design provides minimum pressure drop and large flow capacity to the pump, resulting in higher flow rates and greater pump efficiency.
- Unloading is quicker and turn-around faster to provide more profitable operation.

Greater Protection

- Fully automatic operation virtually eliminates operator errors such as forgetting to close the valve after product transfer.
- Fully internal design reduces possibility of spillage that may result from a collision.
- Built-in visual indicator lets the operator know whether the valve seat is in the open or closed position.
- Never a cable problem. These valves cannot be held open by wire or any other means as the valve will not close as expected when the pump is shut-off.

Less Maintenance

- Easily replaceable, high efficiency external filter removes contaminants as small as 20 microns. Filter virtually eliminates orifice clogging, excessive internal filter maintenance and service downtime.
- No need to check or replace air lines, cables or cable connections.

Economical

- Completely equipped with mounting bolts, flange gaskets, quick acting valve and filter - all in one purchase price.
- No need to purchase additional mounting equipment or actuating accessories.
- Specify RegO Internal Valves on your next new tank body or when your tank is rebuilt.



A7883FK

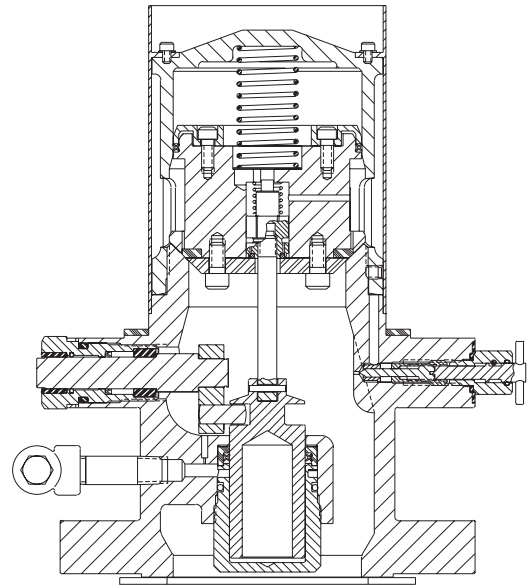

Materials

Body	Cast Steel
Valve Stem	Stainless Steel
Operating Stem	Stainless Steel
Piston.....	Aluminum
Cylinder	Stainless Steel
Screen	Stainless Steel
Seats	Resilient Synthetic Rubber

Ordering Information

Part Number	Inlet Connection ANSI Flange	Outlet Connection ANSI Flange	Strainer Width	Base Width	Overall Height (Approx.)	Height from Indicator to Base	Accessories (included with Flomatic®)	
							Filter	3-Way Valve
A7883FK	3"-300#**	3"-300#	4 3/4"	8 1/4"	10 7/8"	4 13/16"	A7884-201	A7853A

*Supplied with A7853A 3-way valve, A7884-201 filter, studs, nuts and gaskets.

**With 4 1/8" diameter bore.

***With 5 1/8" diameter bore.

Flomatic® Internal Valve Operation

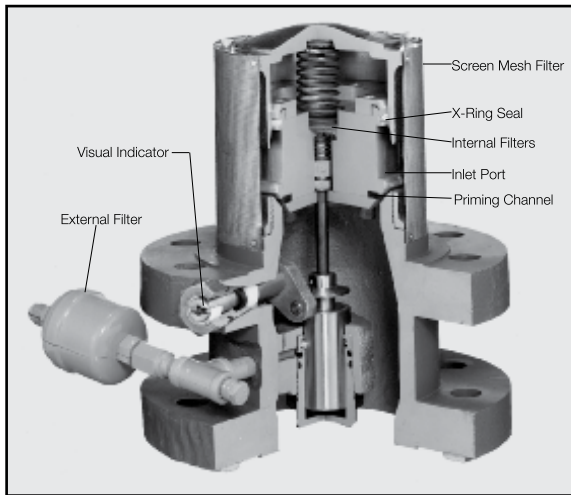

1. Normally Closed

When the valve is closed, liquid flows into the INLET PORTS, through a channel in the PISTON, and into area A. It also flows down through the PRIMING CHANNEL in the valve body, into area B beneath the valve seat, and into area C to prime the PUMP.

1

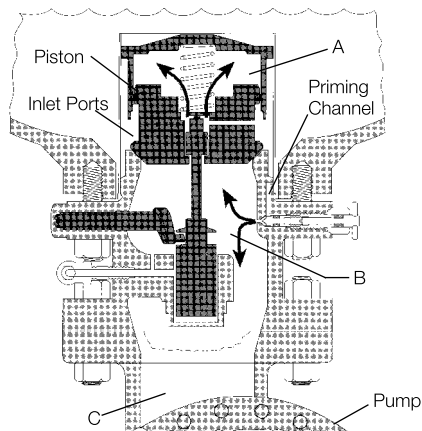

2. Pump On – Valve Opening

When the pump is started, differential pressure transmits through the 1/4" piping into chamber D. lifting the PILOT STEM. This opens the seat between the stem and piston at E. Pump suction then evacuates the tank pressure in area A, which becomes equal to the pump suction pressure.

2

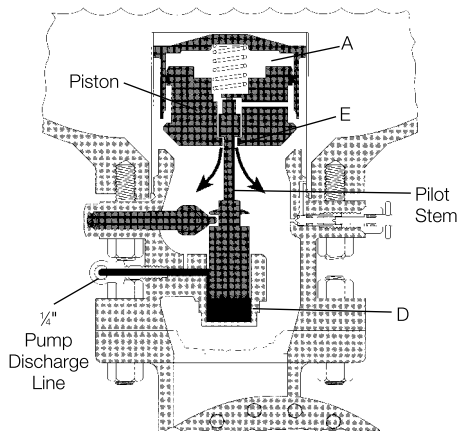

General Information

RegO piston type Flomatic Internal Valves are normally closed and use pressure differential to provide completely automatic service. Mounted directly between the tank body and pump, the Flomatic® uses the pressure differential developed by the pump to open the valve and it closes automatically when the differential no longer exists.

This means the RegO Flomatic opens when the pump is on and closes when the pump is shut off – fully automatic.

3. Pump On – Valve Open

The force below the pilot stem forces the piston up to open the valve; rotating the INDICATOR SLOT to its vertical (valve open) position. Pump differential pressure in area D holds the PILOT STEM and PISTON open. Approximately 20 psig pump differential pressure is required to open the valve; approximately 8 psig differential pressure will hold the valve open.

3

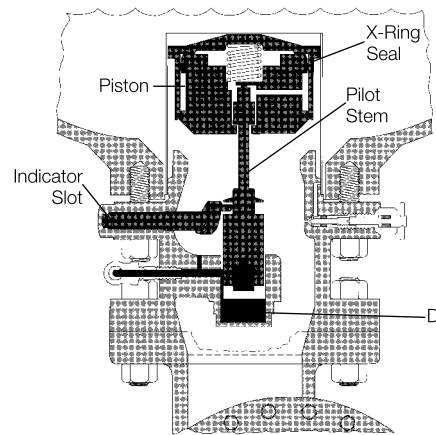

4. Pump Off – Valve Closes

With the pump shut off, the pressure in area D which holds the valve open, bleeds out through the #60 DRILL ORIFICE. This loss of pressure permits the SPRING to push the PILOT STEM down to reseat at point E. Since pressures are equal above and below the PISTON, with no sustaining pressure in area D, the SPRING forces the valve closed. The INDICATOR SLOT rotates to the horizontal (valve closed) position.

4

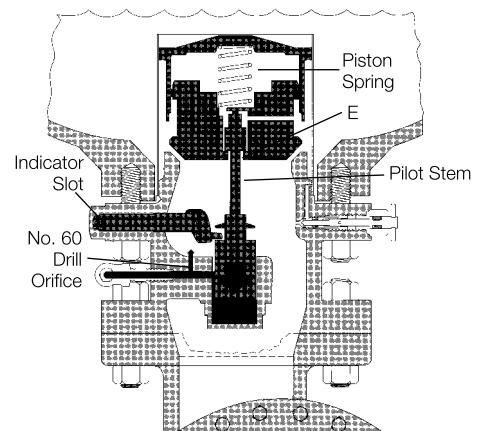

1/4" Three-Way Quick-Acting Valve A7853A



Flow Characteristics

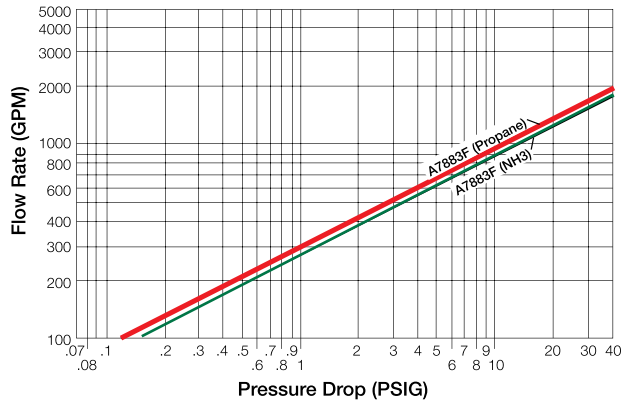

A7853A 1/4" Three-Way Quick-Acting Valve

REGO
10
YEAR
WARRANTY

Typical Installation

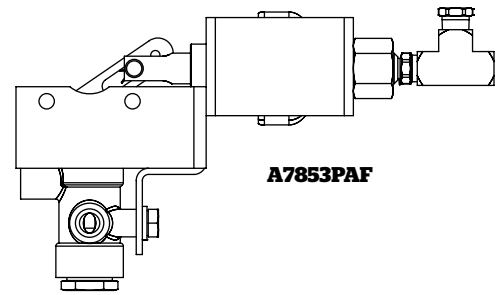
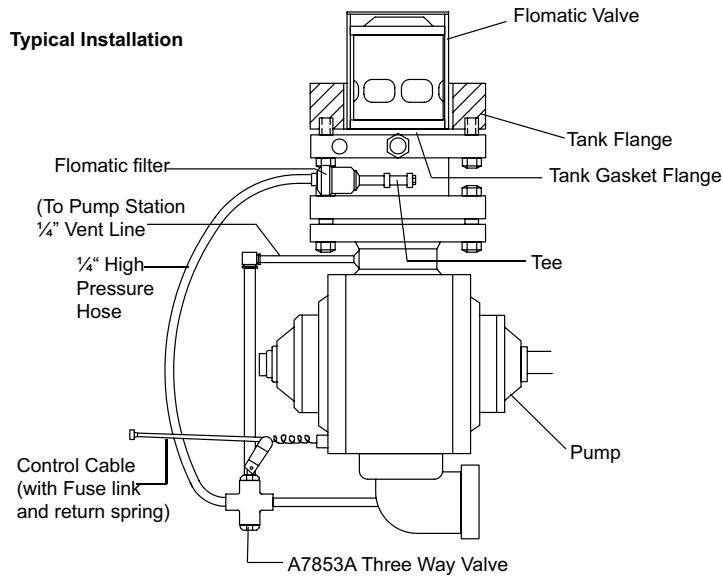

A7853PAF

Flange Dimensions

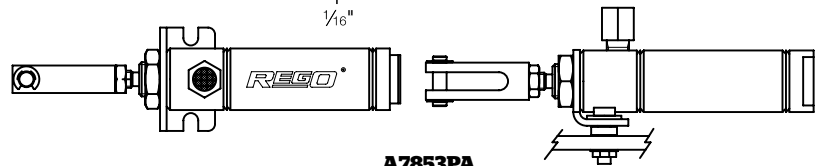
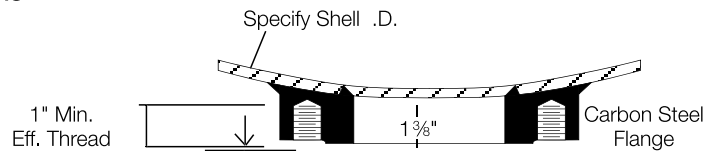
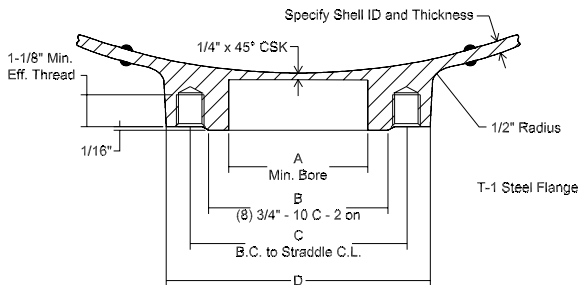

A7853PA

Ordering Information

Part Number	Flange Type	A	B	C	D	Accessories	
						Pneumatic Actuator	3-Way Valve
A7853A	T-1 Steel Carbon Steel	4 ¹³ / ₁₆ "	5 ³ / ₄ "	6 ⁵ / ₈ "	8 ¹ / ₄ "	A7853PAF	A7853PA

*Supplied with A7853A 3-way valve, A7884-201 filter, studs, nuts and gaskets.

**With 4³/₈" diameter bore.

***With 5¹/₈" diameter bore.

On-The-Job Service Guide for the Flomatic® Valve

Introduction

Efficient, profitable transport and delivery truck operations depend on keeping the equipment working safely and efficiently under changing conditions. It is important to know how to eliminate expensive delays by handling unloading problems as they arise.

The purpose of this technical guide is to provide basic information on the Flomatic® valve, along with simple, appropriate steps to follow in the event things go wrong.

The Flomatic® valve is mounted on the bottom of your transport or delivery truck tank, with the pump mounted immediately downstream. When the pump starts to push the liquid down the piping, the Flomatic® Valve opens automatically, allowing you to unload the tank, and closes when the pump stops pushing. It takes at least 20 pounds per square inch of "push" at the pump to open the valve.

Your flanged Flomatic® valve has an indicating shaft on it that shows whether it's open or closed (Figure 1). If the indicating shaft is horizontal, the valve is closed. If it's vertical, the valve is open.

A threaded type, diaphragm-operated Flomatic® valve has an indicating shaft on the bottom, covered by a clear plastic hood. The indicating shaft projects down when the valve is closed and is concealed when the valve is open (Figure 2).

Important Facts About Pressure

When handling propane or anhydrous ammonia, storage and transport tank pressures vary from about 20 pounds per square inch or less when it's cold to 200 pounds per square inch or more in hot weather (Figure 3). If you're hauling butane, tank pressures will be 50 pounds per square inch or less.

The transport or delivery truck tank pressure may be higher than the storage tank pressure when you are ready to unload (Figure 4). This is because your rig may have been freshly loaded at the terminal or bulk plant without a vapor equalizing line and hasn't had time to get back to normal. Also, the storage tank pressure tends to drop when a lot of LP-Gas is being used.

Troubleshooting on the Job

O.K. So you follow your procedures, hook up your hoses, open the required valves and start your pump. The indicating shaft on the Flomatic® valve moves to the open position and the liquid goes in to storage. Great! You're happy and so is the boss, and so are we.

But, let's say you do these things, start the pump and the liquid doesn't move. Now, how do you find out what is wrong?

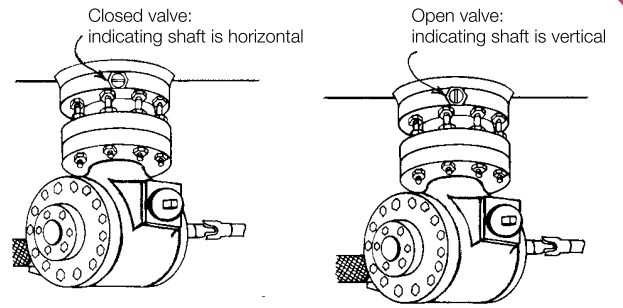

Figure 1. Flanged Flomatic Valve

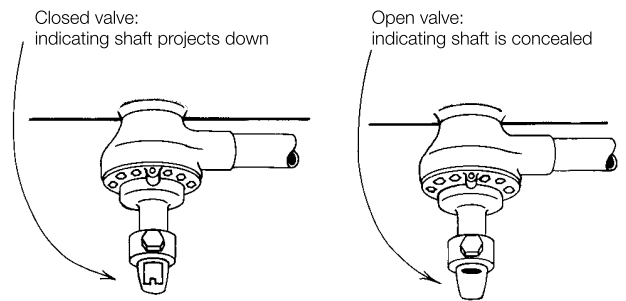

Figure 2. Threaded, Diaphragm-operated Flomatic Valve

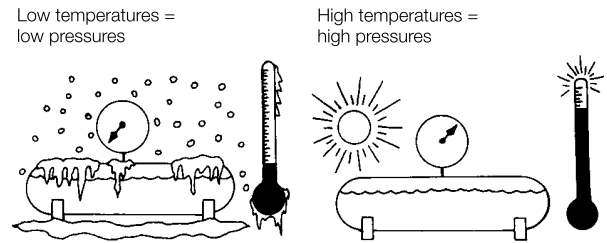

Figure 3. Weather Conditions Affect Pressure

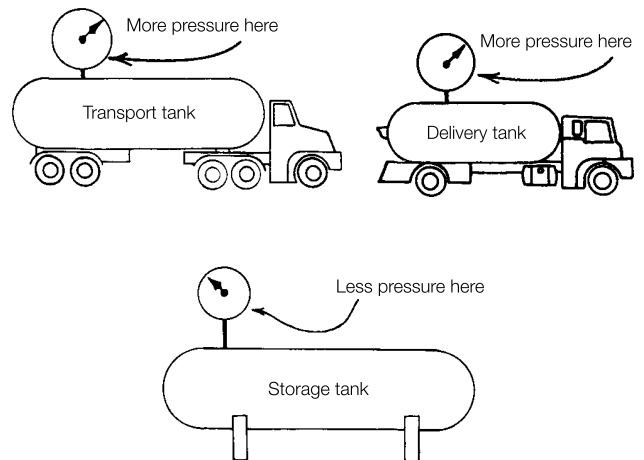

Figure 4. Unloading Conditions Affect Pressure

On-The-Job Service Guide for the Flomatic® Valve

Step 1

Immediately shut down the pump so you don't cause possible damage to the seals or valves. Next:

1. Check all manual valves in the system to make certain they are open or closed as required for proper operation.
2. Check the liquid level in the transport or delivery tank. If the level is low, it may slow the transfer rate.
3. Check to ensure that the pump rotates normally when power is applied. If not, inspect and repair as needed the power takeoff, universal joints, drive shaft and clutch, etc.
4. Make sure the lever is straight out on the ¼" operating valve in the line between the pump discharge line and the Flomatic® valve (Figure 5). If it isn't, the Flomatic® valve will remain closed.
5. Make certain the priming valve on the side of the Flomatic® valve is open (Figure 6).

6. Ice in the system may prevent proper operation, as will a collapsed or kinked sensing line or a clogged sensing line filter. If you found the trouble within STEP 1, just start the pump and continue unloading. If not, proceed accordingly.

a. New Models with T-handle: To adjust to the proper position, push in the end of the valve stem and tighten the needle valve clockwise until it seats. Then, turn counterclockwise 1½ turns.

b. Old Models with Plug: To adjust to the proper position, carefully remove the plug. A small amount of liquid LP-Gas may be discharged when plug is loosened. Insert a small screwdriver and tighten the needle valve clockwise until it seats. Then turn it counterclockwise 1 turn only. **CAUTION: Do not open needle valve more than 1 turn as it might blow out!**

c. Threaded Models with Internal Priming Channel. The internal priming channel normally self-actuates. To be sure the system is primed, remove the plastic hood and push the travel indicator up about ¼" and hold for at least 15 seconds.

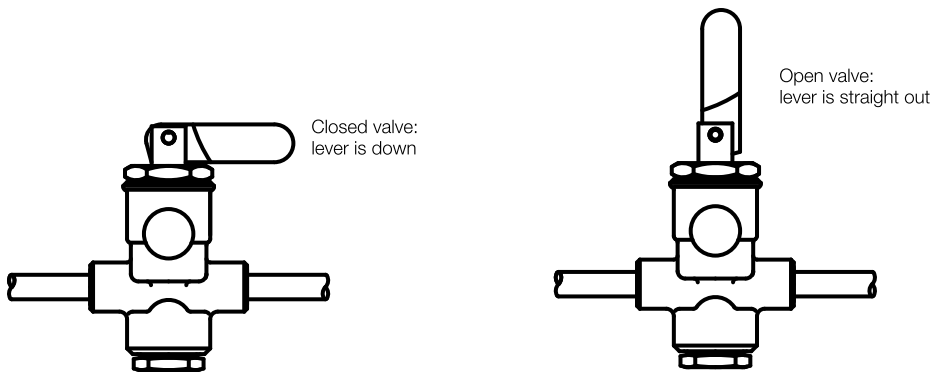

Figure 5. Operating Lever Positions

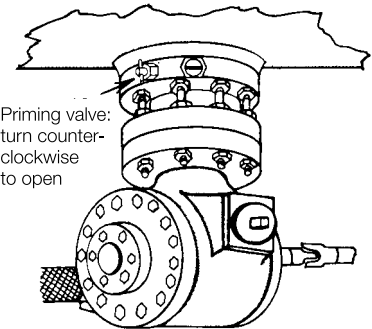

Figure 6. Priming Procedures

For Transport Trailer Trucks Only (Figure 7a)

1. Check the difference between the pressure in your transport and the storage tank. If there's 15 or 20 pounds per square inch more pressure in the transport tank than in the storage tank, chances are the Flomatic® valve won't open. This is because the pump can't develop enough "push."

If you have a good bypass valve on your rig to send the extra liquid back into the tank, you can merely close the liquid shut-off valve in the discharge line and restart your pump (Figure 8a). Now, the Flomatic® indicating shaft should move to the open position (see Figures 1 and 2).

2. Slowly open the liquid shut-off valve in the discharge line and the liquid will start to move out of the transport. If the Flomatic® valve indicating shaft starts to move toward the closed position once you've opened this liquid shut-off valve all the way, throttle the valve for a while until the transport tank pressure drops to where the Flomatic® valve indicating shaft will stay open. Then, open the liquid shut-off valve all the way until you finish unloading.

Step 2

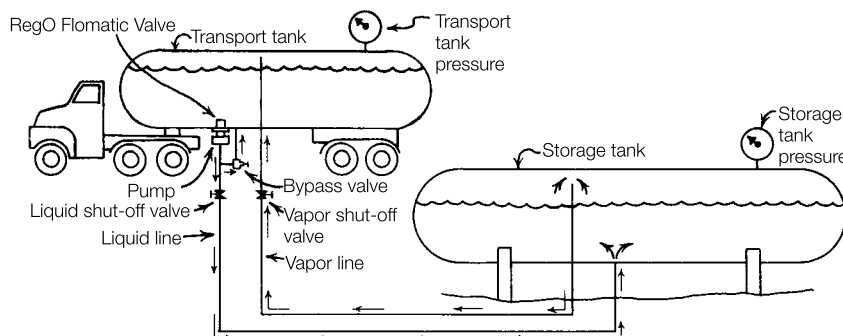

Figure 7a. Unloading Diagram of Transport Trailer Truck

The liquid flows out of the transport tank through the Flomatic® valve, into the pump and through the delivery hose to the storage tank. The vapor line allows vapor to flow from storage back to the transport so that the storage tank pressure won't build up too much and make the pump work harder than necessary.

On-The-Job Service Guide for the Flomatic® Valve

3. If your pump system doesn't have a bypass valve, the liquid shut-off valve in the discharge line should be left partially open when you restart the pump. Just be sure that the pump is pushing at least 20 pounds per square inch, so the Flomatic® valve can open.

Don't worry about how much it may slow up your loading speed when you pinch down the liquid shut-off valve to get the Flomatic® valve open. Your pump is running at constant RPM and will move liquid at almost the same rate, even when pushing harder. (It's a lot like using engine braking on a downhill grade, except, in this case, the pump keeps the liquid moving at a constant flow rate.)

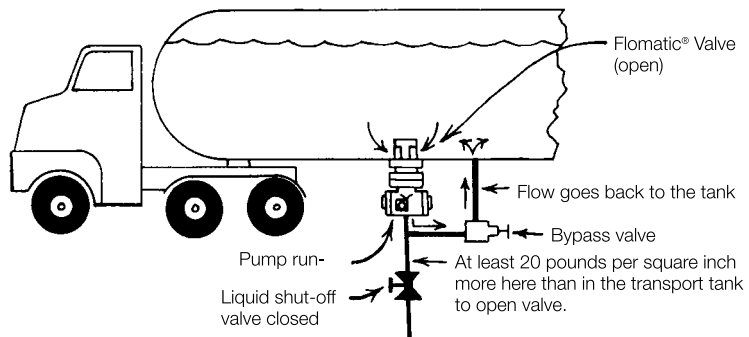

Figure 8a. Unloading Diagram of Transport Trailer Truck with Back-to-tank Bypass Valve
You must have a separate back-to-tank bypass valve if the pump is to be run with the liquid shut-off valve closed.

For Delivery Trucks Only (Figure 7b)

1. Check the pump bypass piping. If your truck is equipped with a manual bypass valve, close it and try the pump again. (Figure 8b). If the Flomatic® valve indicating shaft moves to the open position, the problem is that the pump can't develop 20 pounds per square inch or more to "push" open the Flomatic® valve with the bypass valve open. You can prevent this in the future by not opening the manual bypass valve too wide.

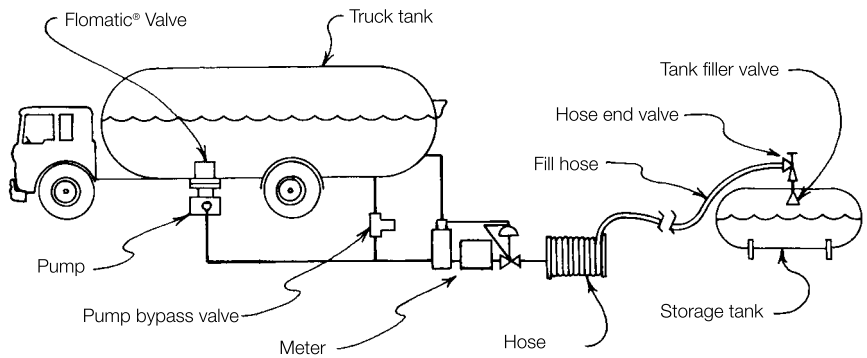

Figure 7b. Unloading Diagram of Delivery Truck

The liquid flows out of the truck tank, through the Flomatic® valve and into the pump, where it is then pushed through the meter and delivery hose into the storage tank. The liquid normally enters the vapor space of the storage tank to minimize pressure buildup, so a vapor equalizing line is usually not needed. The back-to-tank bypass valve opens to divert excess pump capacity back to the truck tank, preventing the pump from creating too much pressure.

2. If the delivery truck is not equipped with a manual bypass valve, merely start the pump. Slowly close the shut-off valve between the back-to-tank bypass valve and tank. If the Flomatic® valve indicating shaft moves to the open position as you close the valve, the back-to-tank bypass valve may be stuck open, adjusted too low, or the spring may be broken. **CAUTION: Don't close the shut-off valve all the way, because excessive pressures and pump damage may occur.**

3. If the Flomatic® valve indicating shaft remains in the closed position, the problem is either in the pump or the Flomatic® valve.

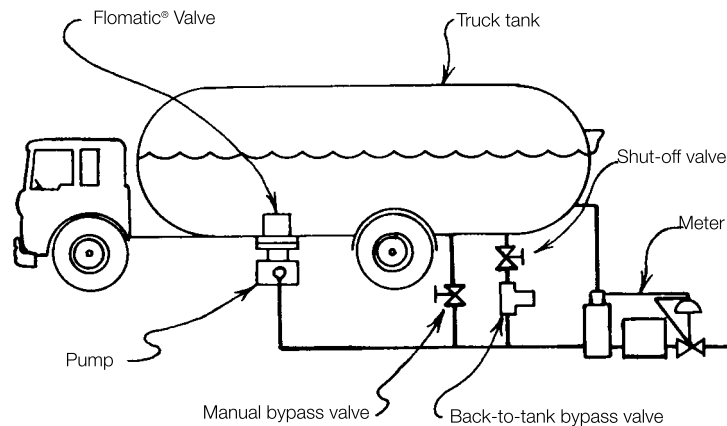

Figure 8b. Unloading Diagram of Delivery Truck with Manual Bypass Valve

USE EXTREME CARE AT ALL TIMES WHEN WORKING AROUND YOUR VEHICLE!
Watch out for drive shafts and moving parts. It is common knowledge that serious injury can result if any part of one's body or clothing is caught in moving machinery.

If you manually open the Flomatic® valve, you are responsible for safely unloading the liquid and closing the valve when you're through. If this procedure is being followed, under no circumstances must the valve be left unattended. The valve must never be permanently held in the open position.

If you are not able to cause the Flomatic® valve indicating shaft to move to the open position after completing the preceding steps, a complete detailed diagnosis will have to be made.

In the meantime, you can actuate the flanged Flomatic® valve by using a special wrench and attempt to unload manually (Figure 9).

If you still can't unload by following the preceding steps, it is suggested that you unload by an alternate method, such as through the valve normally used for liquid filling.

In any event, if you haven't solved the problem and the unit still doesn't operate properly, immediately take it out of service, have a complete analysis made and repair as needed.

Be sure to obtain and keep available for quick referral the Manufacturers' Operation and Service Manuals for the valves, pump, meter and all operating equipment in the system.

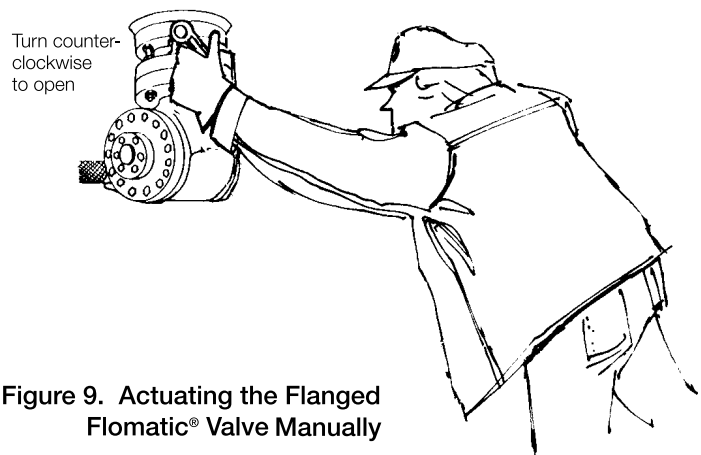

Figure 9. Actuating the Flanged Flomatic® Valve Manually

Pumping System Troubleshooting Guide

Introduction

Most LP-Gas and anhydrous ammonia systems use pumps to move liquid from one location to another. Unloading transport trailer tanks into plant storage, loading delivery trucks, filling bulk tanks, engine fuel tanks, portable cylinders, etc. and pressurizing LP-Gas vaporizers are only a few of many such applications. A well-designed and properly installed pumping system will perform well for some time, but eventually problems occur requiring attention.

Finding out what is wrong, and getting it working again, can be a time-consuming and confusing experience, unless one knows clearly how to proceed.

The purpose for this technical guide is to provide simple, step-by-step guidelines for correcting LP-Gas and anhydrous ammonia pumping difficulties.

The procedure includes a preliminary checklist to help find out if the difficulty can be corrected without taking anything apart. Then, it shows how to zero in on more serious problems by using a few pressure gauges to pinpoint the cause.

It is recommended that the pumping system be equipped for easy pressure gauge installation before trouble occurs. Small manual shutoff valves can be installed at proper locations, with plugs inserted in the outlets.

This would allow pressure gauges to be put in easily without removing the LP-Gas or anhydrous ammonia from the system at the time trouble occurs, saving a lot of time and unnecessary expense. Pressure gauges should be installed temporarily at the time the system is first installed, and pressure readings recorded while the system is working properly. Then, in many cases, merely comparing pressures with original readings may tell what the trouble is.

NOTE: The figure below shows where pressure gauges should be installed. Pressure gauge readings from the original tests should be recorded for each gauge.

It is recommended that the pressure gauges not be used continuously, because vibrations and the ravages of weather cause their damage or ruin. Therefore, as soon as the initial tests are complete, it is best to (1) close the shutoff valves, (2) remove the gauges, (3) plug the valves and (4) keep the gauges in a safe place, ready for troubleshooting when really needed. It is easier to diagnose a problem if the original test results are available, but don't panic if they aren't. You can still solve the problem without this information, but it requires more time and effort.

Pump System Schematic

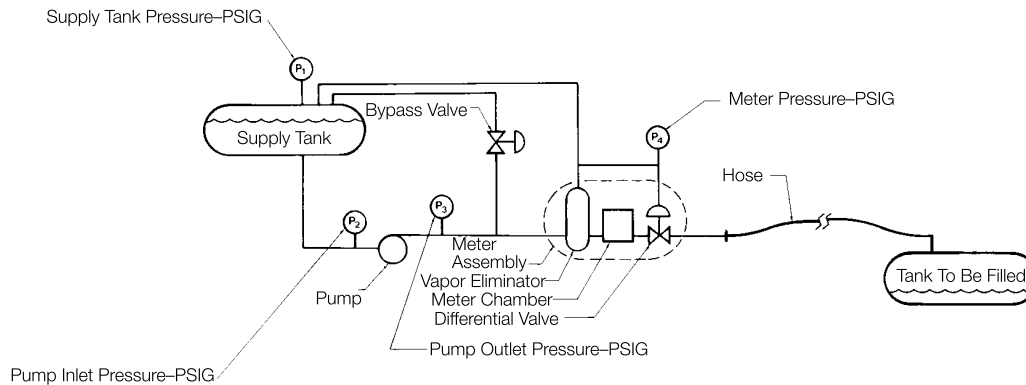

A



Tank Pressure doesn't change



Pump Inlet Pressure decreases



Pump Outlet Pressure doesn't change

The trouble is most likely somewhere in the inlet line. It could be:

1. The pump may be running at a speed too low to develop proper differential pressure.
2. An inlet strainer is clogged.
3. A valve is partially closed somewhere in the inlet line.
4. Ice has formed either in the bottom of the supply tank or somewhere in the inlet line. This is common particularly when the tank has been hydrostatically tested or purged with steam, and not completely drained and dehydrated.
5. If a Flomatic® valve is used, it may not be opening for a number of reasons.
 - a. Pressure in the tank to be filled may be considerably less than that in the supply tank, making it impossible for the pump to develop sufficient differential pressure to open the valve. (Simply throttle a manual valve on the discharge line to cause the pump

NOTE: Meter pressure is not needed for this condition.

- a. to develop enough differential pressure to open the Flomatic® valve. As the pressure in the tank to be filled goes up, it will be possible to re-open the valve in the discharge line.)
 - b. The pump by-pass valve may be blocked open or have broken or damaged parts, preventing the pump from developing sufficient differential pressure to open the Flomatic® valve. (Pump outlet pressure must rise at least 21 PSI to open the Flomatic® Valve.)
 - c. The Flomatic® strainer, filter, three-way valve or other element in the actuating line is clogged, or the actuating line is kinked.
 - d. The Flomatic® valve internal parts may be damaged or worn. (Refer to installation Manual #A7884F-301 for flanged valves or #L-451 for diaphragm-type threaded valves for repair instructions.)
6. If an internal valve is used, the main valve may not be opening due to insufficient equalization time, broken or damaged valve parts, valve lever in closed position or insufficient excess flow sizing.

B



Tank Pressure doesn't change



Pump Inlet Pressure doesn't change



Pump Outlet Pressure goes up a little

The trouble is most likely related to the pump or by-pass valve. It could be:

1. The pump may have excessively worn parts.
2. The internal by-pass valve in the pump may be blocked open by foreign material, or may have broken or damaged parts.
3. The back-to-tank by-pass valve may be blocked open by foreign material, or may have broken or damaged parts.
4. The manual by-pass valve, if so-equipped, may be open.

NOTE: Meter pressure is not needed for this condition.

Pumping System Troubleshooting Guide

Be sure to obtain and keep available for quick referral the Manufacturer's Operation and Service Manuals for the valves, pump, meter and all operating equipment in the system.

To avoid delays, maintain a complete stock of recommended spare parts on hand for quick repairs.

Follow the steps as shown. Don't assume the answer is known beforehand, or skip any applicable steps. Rather, be thorough and methodical and in most instances, you will solve the problem. On the

other hand, if you have done all of this and still haven't worked out your problem, feel free to call your local distributor or RegO

direct. We will do our best to help. Perhaps, between us, we will be able to solve your problem and add something new to the procedure which could help everyone in the future.

Pumping System Troubleshooting Chart

BASIC ASSUMPTION

The pumping system did work OK, but now the transfer rate is considerably less, or the system won't pump at all.

PRELIMINARY REVIEW

- Check the supply tank liquid level. The transfer rate could be considerably reduced if the level is low, due to vapor bubbles in the line, because of insufficient liquid head, or a vortex effect in the tank. Remember, reduction in the pumping rate from these causes will be more extreme in cold weather when tank pressures are low.
 - Examine the pump drive to make sure the pump is rotating properly. Inspect for loose drive belts, damaged or broken flexible couplings or universal joints, broken drive keys and damaged or inoperative power take-off or pump clutch, etc.
 - If the system is equipped with the Flomatic® Valve:
 - Make sure the three-way valve handle is straight out, allowing the valve to open.
 - Check the position indicator on the Flomatic Valve when the pump is running. If the indicator shows that the valve is open, the trouble **must** be downstream of the valve.
 - If the system is equipped with internal valves, make sure the operating lever moves to a full open position. Repair if needed.
 - Make sure all valves in the system are either open or closed as required for normal operation. Check each valve in sequence, starting from the supply tank, making sure that no valve element is missed
- If the cause of the problem has not been determined during preliminary review, it will be necessary to conduct diagnostic tests, using pressure gauges at key points in the system. (See Introduction, Page 1.)

DIAGNOSTIC TESTS

Open all valves as required for proper pumping operation. Gauges should show tank pressure, pump inlet pressure, pump outlet pressure and meter pressure to be equal.

Start the pump and observe all pressure gauges. Match results with conditions A, B, C, or D. Follow the appropriate steps.

FINAL RESULTS

Make repairs or adjustments as needed, and test the system's operation. Record a new set of test pressures for future reference, and order replacements for all spare parts used.

The system is now ready to return to service.

C

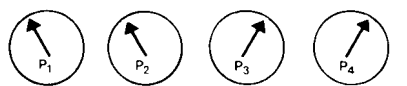

Tank Pressure doesn't change
Pump Inlet Pressure doesn't change
Pump Outlet Pressure rises substantially
Meter Pressure rises substantially

The trouble is most likely in the meter vapor eliminator or meter differential valve. It could be:

- The meter's vapor eliminator may be malfunctioning. If the valve at the outlet of the vapor eliminator does not seat when the vapors have been purged, the differential valve downstream of the meter will not open. Such failure could be caused by a damaged vapor eliminator valve seat, foreign material blocking the vapor eliminator valve, a leak in the ball float, or a jammed or binding linkage between the ball and valve.
- The diaphragm could be ruptured, or other parts could be damaged or broken in the differential valve downstream of the meter.

D



The problem is most likely somewhere downstream of the pump. Look for a closed valve, or some type of blockage in the discharge line. It could be:

- The meter strainer may be clogged.
- A back check valve at the inlet of the meter may be blocked, closed, or jammed.
- The meter rotor may be jammed by foreign material, preventing it from moving properly, which would prevent or retard flow.
- The drive key on the meter gears may be sheared. (In this case, flow would actually be moving through the meter but not registering.)
- The differential valve downstream of the meter may be closed due to damage, foreign material or ice.
- If screw type hose fittings are used, it is extremely important that they be installed properly. If not, it is possible that a flap of rubber may be cut from the inside diameter of the hose, acting as a back check. It can flap across the discharge line, effectively stopping the flow.
- Check the hose nozzle valve, if so equipped. In some brands, a bent handle or other defect may prevent the inner valve from opening sufficiently to allow a proper amount of flow.
- The problem could be in the valve assemblies in the tank to be filled.
- Some delivery trucks are equipped with a quick-acting valve immediately upstream, of the hose reel. **Make sure** that this valve is open.
- Some delivery trucks are equipped with excess flow valves between the meter and hose reel. Improper sizing, a weak spring, or other valve damage can cause this valve to close prematurely, effectively stopping the flow.
- If, with a delivery truck system, the flow reduced considerably while the tank is being filled, it is possible that the back-to-tank by-pass valve is not set high enough to compensate for vapor pressure buildup in the tank being filled. This can be solved merely by adjusting the by-pass valve as a slightly higher level. **Warning:** Do not raise the back-to-tank by-pass setting high enough to cause the internal relief valve in the pump to actuate. If this should happen, it could cause excessive cavitation, loss of capacity and premature pump wear.

FINAL RESULTS

Make repairs or adjustments as needed, and test the system's operation. Record a new set of test pressures for future reference, and order replacements for all spare parts used. The system now is ready to return to service.

Section H
Adapters, Connectors and Fittings



Limited 10 Year Warranty and Limitation Of Liability

LIMITED 10 YEAR WARRANTY

RegO warrants to the original purchasers the products and repair kits manufactured by it to be free from defects in materials and workmanship under normal use and service for a period of 10 years from the date of manufacture. If within thirty days after buyer's discovery of what buyer believes is a defect, buyer notifies in writing and ships the product to RegO at 100 RegO Drive, Elon, NC 27244, RegO, at its option, and within forty-five days of receipt, will repair, replace F.O.B. point of manufacture, or refund the purchase price of that part or product found by RegO to be defective. Failure of buyer to give such written notice and ship the product within thirty days shall be deemed an absolute and unconditional waiver of any and all claims of buyer arising out of such defect.

This warranty does not extend to any product or part that is not installed and used after installation in accordance with RegO's printed instructions, all applicable state and local regulations, and all applicable national standards, such as those promulgated by NFPA, DOT and ANSI. This warranty does not extend to any product or part that has been damaged by accident, misuse, abuse, failure to maintain, or neglect, nor does it extend to any product or part which has been modified, altered, disassembled, or repaired in the field. This warranty does not cover any cosmetic issues, such as scratches, dents, marring, fading of colors or discoloration.

Except as expressly set forth above, and subject to the limitation of liability below, RegO MAKES NO OTHER WARRANTY, EXPRESS OR IMPLIED, INCLUDING, BUT NOT LIMITED TO, THE IMPLIED WARRANTIES OF MERCHANTABILITY AND FITNESS FOR A PARTICULAR PURPOSE, with respect to its products and parts, whether used alone or in combination with others. RegO disclaims all warranties not stated herein.

LIMITATION OF LIABILITY

RegO's total liability for any and all losses and damages arising out of any cause whatsoever shall in no event exceed the purchase price of the products or parts in respect of which such cause arises, whether such cause be based on theories of contract, negligence, strict liability, tort or otherwise.

RegO shall not be liable for incidental, consequential or punitive damages or other losses. RegO shall not be liable for, and buyer assumes any liability for, all personal injury and property damage connected with the handling, transportation, possession, further manufacture, other use or resale of products, whether used alone or in combination with any other products or materials.

From time to time buyers might call to ask RegO for technical advice based upon limited facts disclosed to RegO. If RegO furnishes technical advice to buyer, whether or not at buyer's request, with respect to application, further manufacture or other use of the products and parts, RegO shall not be liable for such technical advice or any such advice provided to buyer by any third party and buyer assumes all risks of such advice and the results thereof.

NOTE: Some states do not allow the exclusion or limitation of incidental, consequential or punitive damages, so the above limitation or exclusion may not apply to you. The warranty gives you specific legal rights, and you may have other rights that vary from State to State. The portions of this limited warranty and limitation of liability shall be considered severable and all portions which are not disallowed by applicable law shall remain in full force and effect.

WARNING

All RegO products are mechanical devices that will eventually become inoperative due to wear, corrosion and aging of components made of material such as rubber, etc. The environment and conditions of use will determine the safe service life of these products. Periodic inspection and maintenance are essential to avoid serious injury and property damage.

Many RegO products are manufactured components which are incorporated by others on or in other products or systems used for storage, transport, transfer and otherwise for use of toxic, flammable and dangerous liquids and gases. Such substances must be handled by experienced and trained personnel only, using accepted governmental and industrial safety procedures.

NOTICE TO USERS OF PRODUCTS

The Limited Warranty stated above is a factory warranty to the first purchasers of RegO products. Since most users have purchased these products from RegO distributors, the user must within thirty (30) days after the user's discovery of what user believes is a defect, notify in writing and return the product to the distributor from whom he purchased the product/part. The distributor may or may not at the distributor's option choose to submit the product/parts to RegO, pursuant to this Limited Warranty. Failure by buyer to give such written notice within thirty (30) days shall be deemed an absolute and unconditional waiver of buyer's claim for such defects. Acceptance of any alleged defective product/parts by RegO's distributor for replacement or repairs under the terms of RegO's Limited Warranty in no way determines RegO's obligations under this Limited Warranty.

Because of a policy of continuous product improvement, RegO reserves the right to change designs, materials or specifications without notice.

Foreword

This catalog describes a complete line of equipment available from RegO® for use with Liquid Propane (LP)-Gas and anhydrous ammonia (NH₃). The following points are important to know for proper use of the catalog:

1. Illustrations and drawings of individual products are representative of “product groups” and all products within a product group are similar in construction.
2. Materials used for construction of products in this catalog are suitable for rated service pressure at temperatures of -40°F to +165°F, unless otherwise specified.
3. Products in this catalog are only intended for use in LP-Gas and/or anhydrous ammonia service as follows.
 - a. “A” or “AA” prefix — Products with this prefix are suitable for NH₃ service (i.e., contain no brass parts).
 - b. “AA” prefix on relief valves — These valves are NOT suitable for use with LP-Gas service. These are of partial aluminum materials and are listed by Underwriters Laboratories (UL) for NH₃ service only.
 - c. All other products including “A” prefix are suitable for use with LP-Gas & NH₃ service.
 - d. “SS” prefix—Hydrostatic relief valve with this prefix are suitable for NH₃ and LP-Gas service (i.e., they have stainless steel materials).
4. We manufacture valves and adapters designed to be used on LP-Gas and Anhydrous Ammonia systems, we do not design systems or consult in system design. For this type of information consult a professional Engineer.

Caution

Do not use any product contained in this catalog with any service commodity other than LP-Gas or NH₃. If you have a need for use of another application, contact RegO, 100 RegO Drive, Elon, NC 27244, (336) 449-7707 ecii@regoproducts.com before proceeding.

Proper application, installation and maintenance of products in this catalog are essential. Users of these products should obtain further information if there are any doubts or questions.

Warning

All RegO products are mechanical devices that will eventually become inoperative due to wear, corrosion and aging of components made of materials such as rubber. The environment and conditions of use will determine the safe service life of these products. Periodic inspection and maintenance are essential to avoid serious injury and property damage.

Many RegO products are manufactured for storage, transport, transfer and use of toxic flammable and dangerous liquids and gases. Such substances should be handled by experienced and trained personnel only, using accepted governmental and industrial safety procedures. Never vent LP-Gas near any possible source of ignition.

Notice

Installation, usage, and maintenance of all RegO products must be in compliance with all RegO instructions as well as requirements and provisions of NFPA #54, NFPA#58, DOT, ANSI, and all applicable federal, state, provincial and local standards, codes, regulations, and laws.

Inspection and maintenance on a periodic basis is essential. Installation and maintenance should be performed only by qualified personnel.

Be sure all instructions are read and understood before installation, operation and service.

Filters

RegO LP-Gas equipment is designed to operate in a system free from contamination. A variety of in-line filters are commercially available to the LP-Gas industry for installation in domestic systems.

The use of an in-line filter should be considered when other system components may be unclean and the system contaminated by rust, scale, dirt, debris or other foreign material.

Extended Type Hose Couplings for Vapor and Liquid Service A7571 and A7575 Series

Application

Designed especially for liquid filling and vapor equalization of LP-Gas and anhydrous ammonia. The limited travel of the handle on the tailpiece minimizes spin-off, encouraging cautious removal to properly bleed off trapped product to ensure closure of the filler valve and hose end valve. The ACME threads are machined on a rugged steel insert which is permanently cast in the aluminum handle, providing for durability under repeated use.

Features

- Lightweight aluminum handle is contoured and ribbed for added comfort, easy handling allows for easy make-up.
- Free swivel action between tailpiece and handle allows for easy make-up.
- Simplified design eliminates an extra joint and provides smooth, uninterrupted flow.

Materials

Handle Aluminium
 ACME Threads Steel Inlet
 Restraining Ring Stainless Steel



A7571 Series

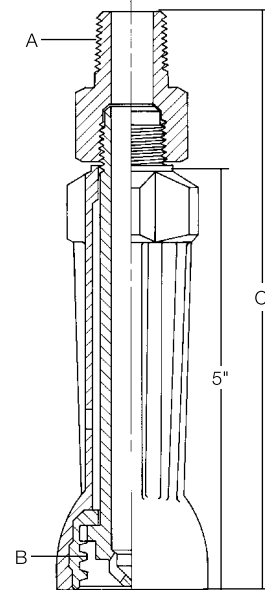

For Vapor Equalizing



A7575 Series

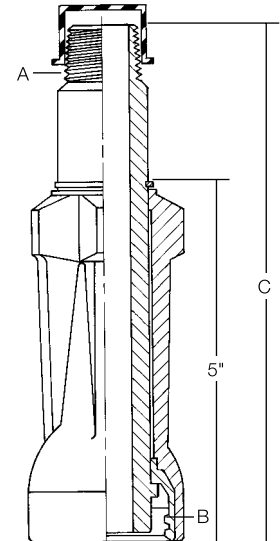

For Liquid Filling



Ordering Information

Part Number	Type of Service	A. Hose Connection (M. NPT)	B. Coupling Connection (F. ACME)	C. Approx. Length
A7575L2*	Liquid	1/2"	1 3/4"	7"
A7575L3		3/4"		
A7575L4		1"		
A7575L5**		1 1/4"		
A7571LA	Vapor	1/2"	1 3/4"	7"
A7571LB		3/4"		

* Includes 7199-33 adapter, shipped loose.
 ** Includes A7575L5-1 adapter, shipped loose.

Short Type Hose Couplings for Vapor and Liquid Service 3171, 3175, 3181, 3185 and 3195 Series



3175 Series

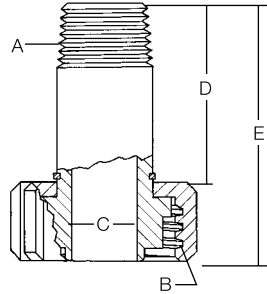

**Style A
For Liquid Filling**



A3185 Series

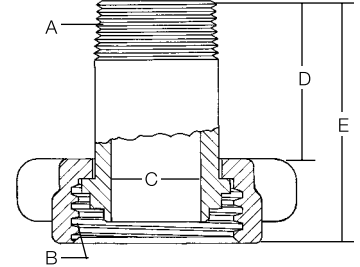

**Style B
For Liquid Filling**



3171A Series

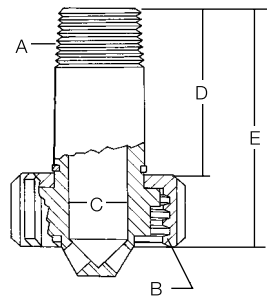

**Style C
For Vapor Equalizing**



3191 Series

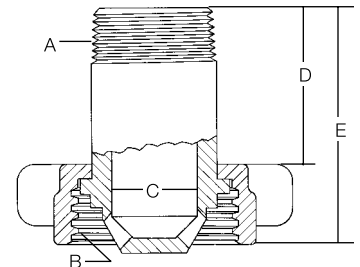

**Style D
For Vapor Equalizing**



Ordering Information

Part Number	Material	Style	A. Hose Connection (M. NPT)	B. Coupling Connection (F. ACME)	C. Tailpiece Bore	D. Hose End To Nut	E. Overall Length
3175B	Brass	A	1/2"	1 1/4"	35/64"	1 13/16"	2 1/16"
3175			3/4"		3/4"		
3175A			1"		15/16"		
3185	Brass Nut & Steel Nipple	B	1 1/4"	2 1/4"	1 3/16"	2 11/16"	3 3/4"
3195			2"	3 1/4"	7/8"	2 1/4"	3 5/8"
A3175	Steel	A	3/4"	1 3/4"	3/4"	2"	2 7/8"
A3175A			1"		7/8"	2 1/4"	3 1/8"
A3185		B	1 1/4"	2 1/4"	1 1/4"	2 1/8"	3 3/16"
A3195			2"	3 1/4"	1 7/8"	2 1/4"	3 5/8"
3171	Brass	C	3/8"	1 1/4"	3/8"	1 11/32"	2 19/32"
3171A			1/2"		31/64"		
3181			3/4"		3/4"		
3181A		1"	3/4"	1 7/8"	2 3/4"		
3191		D	1 1/4"	2 1/4"	1 3/16"	2 7/8"	3 3/16"

ACME Check Connectors for Lift Trucks 7141F and 7141M

Application

These brass connectors are especially designed to join the carburetor fuel line to the service valve on lift truck cylinders. Sturdy, long lasting ACME threads allow quick, hand-tight assembly that provides for quick and simple cylinder replacement. Back checks automatically close in each connector when disconnected.

The 7141M couples directly to the service valve. An integral O-ring is designed to seal before the internal check opens, aiding in product loss prevention. A gasket at the ACME thread is a secondary seal when the connectors are tightened together. The connector fits RegO lift truck cylinder filling adapters for fast, convenient filling.

The 7141F accepts fuel line adapter and couples directly to the 7141M. The O-ring seal in the 7141M is designed to seal before the internal check opens to allow product to pass through the connection. The knurled coupling eases threading and the ACME threads provide rapid effortless make-up, even against LP-Gas pressure.

NOTE: Refer to the "Cylinder and Service Valves" section of the L-500 catalog for additional information.



7141M

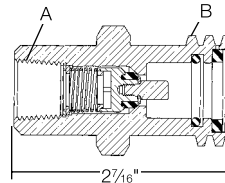

7141F

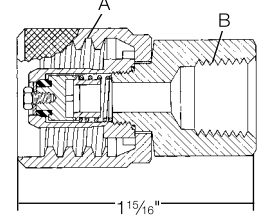

Ordering Information

Part Number	Application	A. Inlet	B. Outlet	Protective Cap*	
				Rubber	Brass
7141M	Service Valve	3/8" F. NPT	1 1/4" M. ACME	7141M-40	7141FP
7141F	Fuel Line	1 1/4" F. ACME	1/4" F. NPT	-	-

* Recommended to minimize foreign material entering valves which could result in leakage.

Unloading Adapters for Container Evacuation 3119A, 3120 and 3121

Application

Designed to provide an efficient means of evacuating an LP-Gas container for relocation or repair. They thread directly onto the 1 1/4" ACME male hose connection of RegO Filler Valves used on RegO Double Check Filler Valves and Multivalves®.

The unloading adapters can be used to withdraw liquid provided the container is equipped with a dip pipe extending from the filler valve to the bottom of the container.

Features

- Available in either angle or in-line type configurations.
- Built-in vent valve provides for a controlled release of gas which may be trapped within the unit after use and also helps to indicate closure of the Filler Valve.
- Integral plunger has two different lengths of travel, 1/4" and 1/2", depending on which way the lever is turned. Can be used with all RegO Filler Valves.



3120

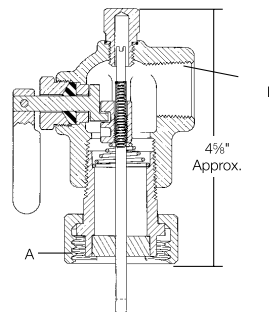

3119A

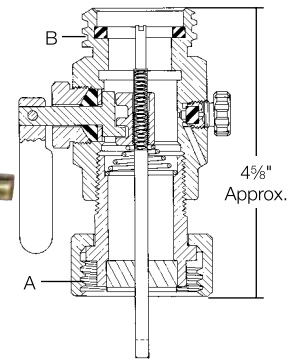

3121

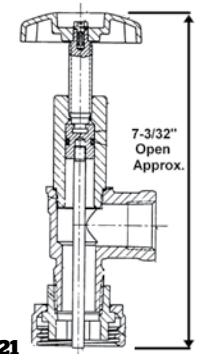

Materials

Body Brass
Plunger Steel

Ordering Information

Part Number	Style	A. Filler Valve Connection	B. Hose Connection
3119A	In-Line	1 1/4" F. ACME	1 1/4" M. ACME
3120	Angle		3/4" F. NPT
3121			

Left Hand Thread ACME Connectors for Vapor Withdrawal Industrial Cylinders 7142LF and 7142LM

Application

These brass connectors are especially designed to join the carburetor **vapor fuel** line to the service valve on industrial cylinders especially designed for and used on propane fueled lawn mowers. Sturdy long lasting ACME **left hand** threads provides for quick hand tight assembly that provides for quick and simple cylinder replacement.

Features

- The 7142LM couples directly to the service valve.
- An integral O-ring is designed to seal before the internal check opens, aiding in product loss prevention.
- A gasket at the ACME thread when the connectors are tightened together.
- The 7142LF accepts the **vapor fuel** line adapter and couples directly with the 7142LM.
- The O-ring seal in the 7142LM is designed to seal before the internal check opens to allow product to pass through the connection.
- The knurled coupling nut proves for easy make-up even against LP-Gas vapor pressure.



7142LM

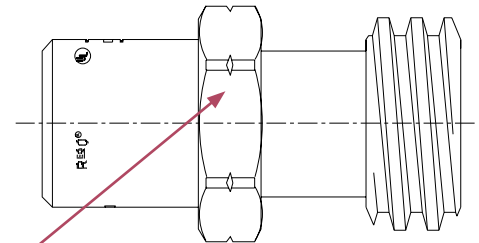

Lines across wrench flats indicate left hand thread male ACME connection.



7142LF

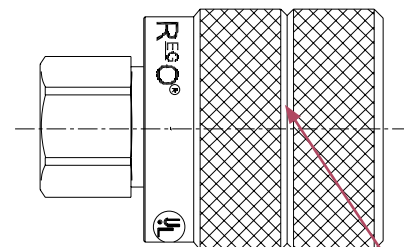

Solid line around coupling nut indicates left hand thread female ACME connection.



Ordering Information

Part Number	Application	Inlet	Outlet	Protective Cap
7142LM	Vapor Service Valve	3/8" F.NPT	1 1/4" M.ACME –left hand	7141M-40
7142LF	Vapor Fuel Line	1 1/4" F.ACME –left hand	1/4" F.NPT	-

Filler Hose Adapters

3179B, 7577V and 7576



3179B

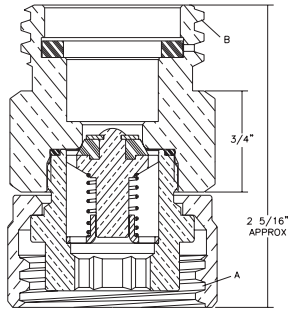

7577V

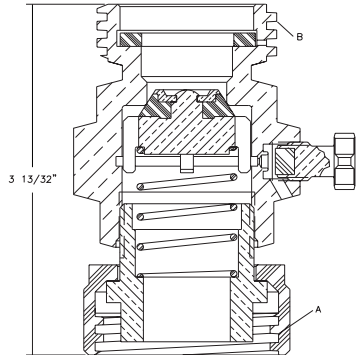

7576

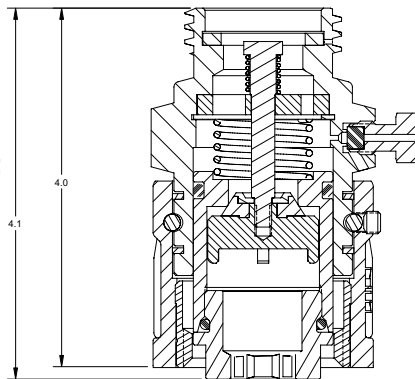

These adapters are designed with minimal flow restriction and recommended for use on the outlet of the LP-Gas delivery truck filler hose. If the controlled bleed off of the connection indicates the filler valve on the tank being filled has failed to close, the hose adapter should be left in place on the filler valve and disconnection should be made at the regular filler hose coupling. (Repair of the filler valve must be made as soon as possible). An integral check valve in these adapters helps prevent further loss of product. The standard filler valve cap should be attached to these adapters when left on the container.

Ordering Information

Part Number	Built-in Vent Valve	A Filler Valve Connection	B Hose Connection
7577V	Yes	1 1/4" F. ACME	1 1/4" M. ACME
3179B	No		
7576	Yes		



H

POL Plugs



10538P
(Has hole for attaching wire to prevent loss of plug)



N970P

Highly recommended for installation in LP-Gas cylinder valve POL outlets whenever the service line is disconnected or when the cylinder is being transported.

When properly installed, the POL plug is designed to prevent contamination of the valve outlet and guards against product leakage if the cylinder valve is accidentally opened.

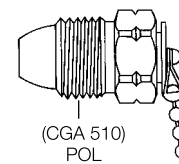
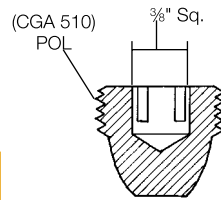

3705RC
W/Chain & Ring



Ordering Information

Part Number	Material	Connection
N970P	Cyclac	M. POL (CGA 510)
10538P	Brass	
3705RC		

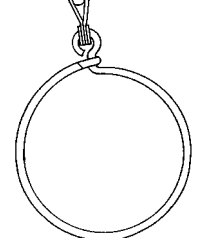

H8

Caps and Reducers

Ordering Information

Cap With Chain & Ring		Cap Only Part Number	Material	Thread Connection																							
Part Number	Ring Fits Pipe Size Up To:																										
3144-91	3/4"	3144-9P	ABS	1 1/4" F. ACME																							
3174-91		3174-9P		1 1/4" F. ACME																							
3174-93		A8016-9P		1 1/4" F. ACME																							
A8016-93	1 1/4"	-	Nylon	F. POL (CGA 510)																							
1708C					3/4"	1 1/4" F. ACME																					
7141FP	-	-	Brass	1 1/4" F. ACME																							
3175P	1 1/4"			1 1/4" F. ACME																							
A3175P	Adjustable Cable		-	Steel	2 1/4" F. ACME																						
3184-90					3 1/4" F. ACME																						
3194-90				2 1/4" F. ACME																							
-				3 1/4" F. ACME																							
-				3 1/4" F. ACME																							
A3184-90	-	-	Steel	2 1/4" F. ACME																							
A3194-90				3 1/4" F. ACME																							
-	1"	A5776*	Brass	1 15/16" F. ACME																							
907FP		-		-	3 1/4" ACME																						
3194-90G						Adjustable Cable	-	-																			
3194-90GS									-	-	-																
3194-91L												-	-	-													
3194-91S															-	-	-										
3194-91V																		-	-	-							
A3194-91L																					-	-	-				
A3194-91S																								-	-	-	
A3194-91V																											-
5778	3 1/4" F. ACME		2 1/4" M. ACME																								

* Reduces to 1 1/4" M. ACME

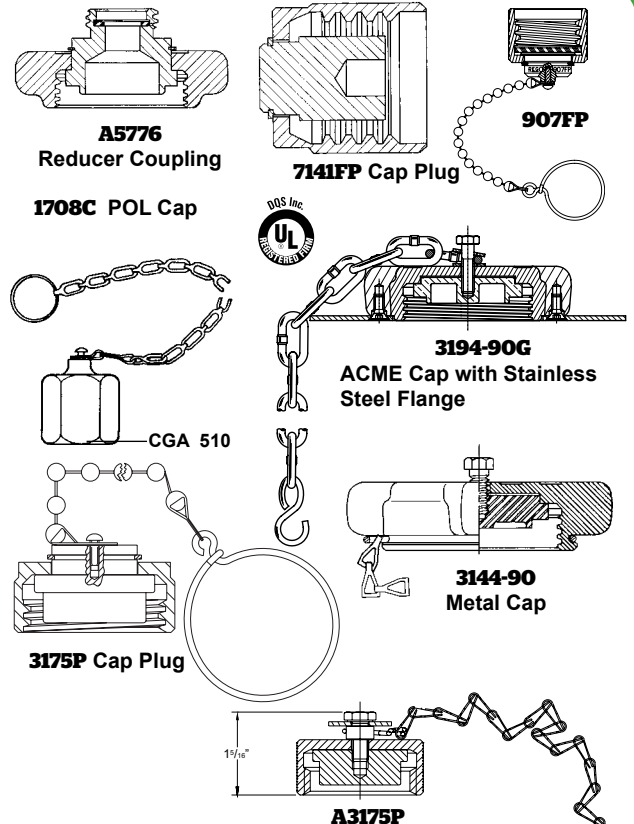
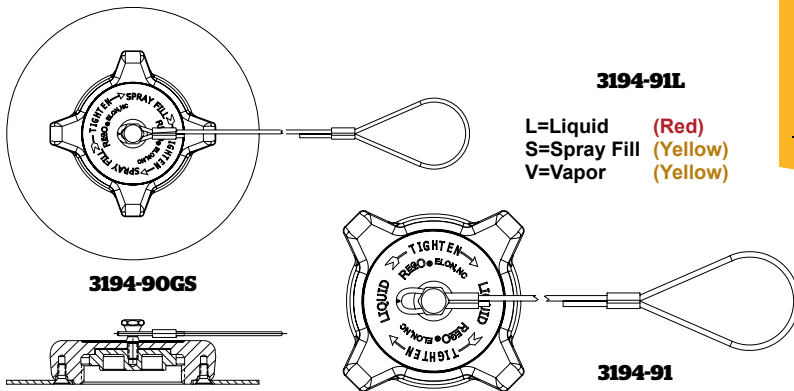

REGO
10
YEAR
WARRANTY

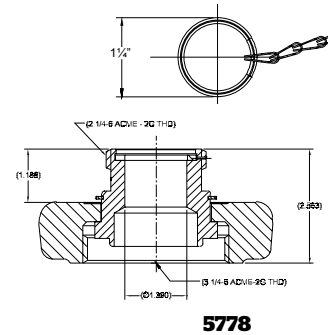

ACME Plugs

Specifically designed to withstand the everyday abuse given to hose end valves on delivery trucks and hose end couplings on risers in bulk plants, these rugged plugs protect the coupling tip as well as prevent the entrance of dirt, dust, snow and rain. They also prevent possible gas contamination from these same sources. The heavily ribbed outer surface permits hand-tight make-up.

These plugs are available in a choice of four sizes which may be used with liquid as well as vapor type couplings. As a convenience, the nylon plugs have a retaining chain and ring to prevent loss during a transfer operation.

All are suitable for LPG or anhydrous ammonia service except the brass 5765PR, which is for LP-Gas only.

Not intended for use as pressure closures.



REGO
10
YEAR
WARRANTY



Ordering Information

Part Number	Material	A (M. ACME)	Chain & Ring Fits Pipe Size Up To:
C5763N	Nylon	1 1/4"	3/4"
C5765N		1 3/4"	1 1/4"
5765PR	Brass	-	Not Applicable
C5767N	Nylon	2 1/4"	1 1/4"
C5769N		3 1/4"	2"

ACME Adapters

Ordering Information

Part Number	Material	A M. ACME	B FNPT	C Hex	D Overall Length	E Diameter	For Spare Gasket Order Part No.
5764A	Brass	1 3/4"	1/4"	1 3/4"	1 3/4"	13/32"	A2697-20R
5764B			3/8"		1 23/32"	9/16"	
5764C			1/2"		1 1/4"	11/16"	
5764D			3/4"		1 1/2"	1 1/8"	
5764E			1"		1 5/8"	1 1/4"	
5766E	Brass	2 1/4"	1"	2 1/4"	2"	1 3/32"	A3184-8R
5766F			1 1/4"		1 3/8"	A3184-8R	
5768G	Brass	3 3/4"	1 1/2"	3 3/4"	1 3/4"	1 11/16"	A3194-8R
A5764D	Steel	1 3/4"	3/4"	1 3/4"	2 3/16"	7/8"	A2697-20R
A5764E			1"				A2697-20R
A5768H			3 3/4"				2"

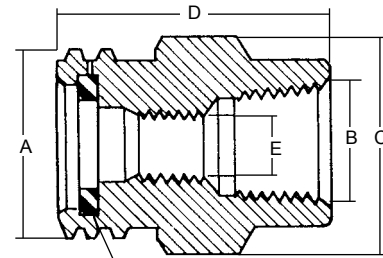

Gasket (Furnished with adapter)
ACME x Female NPT



Ordering Information

Part Number	Material	A M. ACME	B M. NPT	C Hex	D Overall Length	E Diameter	For Spare Gasket Order Part No.			
5763D	Brass	1 1/4"	3/4"	1 1/4"	1 3/4"	1/2"	A2797-20R			
5765D			3/4"					1 3/4"	2 3/32"	29/32"
5765E			1"		2 3/32"	29/32"				
5765F			1 1/4"							
5767F			2 1/4"		1 1/2"	2 1/4"		2 3/8"	1 3/8"	A3184-8R
5767G	2"	2 5/8"	2 7/16"	1 25/64"	A3184-8R					
5767H	3 1/4"	3"	3 1/2"	3 5/8"	2 1/8"	1 7/32"	A3194-8R			
A5765C	Steel	1 3/4"	1/2"	1 3/4"	2 3/16"	17/32"	A2697-20R			
A5765D			3/4"			11/16"				
A5765E			1"			57/64"				
A5765F			1 1/4"			57/64"				
A5767F			2 1/4"			1 1/4"		2 1/4"	2 3/8"	1 1/4"
A5769H	Steel	3 1/4"	2"	3 1/4"	2 7/8"	1 15/16"	A3194-8R			
A5769K			3"					4"	3 13/16"	

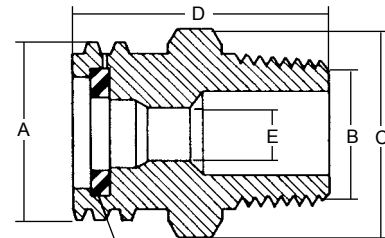

Gasket (Furnished with adapter)
ACME x Male NPT

Ordering Information

Part Number	Material	A M. ACME	B Hex	C Overall Length	D Diameter	For Spare Gasket Order Part No.
5765M	Brass	1 3/4"	1 1/4"	2"	29/32"	A2697-20R
5767M		2 1/4"	2 1/4"	2 7/16"	1"	A3184-8R
5769M		3 1/4"	3 1/4"	2 3/4"	1 15/16"	A3194-8R

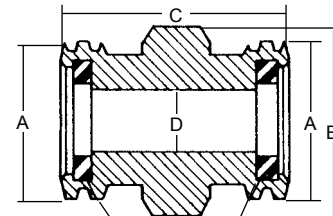

Gasket (Furnished with adapter)
ACME x ACME

Ordering Information

Part Number	Material	A M. ACME	B F. NPT	C Overall Length	D Diameter	For Spare Gasket Order Part No.
A5764W	Steel	1 3/4"	3/8"	1 1/4"	1 1/4"	2697-20
5764W	Brass					

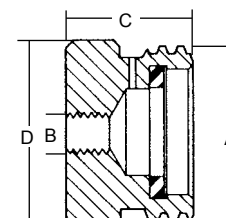

ACME x Miscellaneous
(Recommended for securing hose-end valve when not in use).

* 3/8" -16 UNC Thread.

3/4" M.A.C.M.E.X 2" M.N.P.T Adapter with Vent Valve & Integral Screen 5769HVB

Application

Designed to prevent debris from impeding the action of valves and components of LPG piping systems at bulk plants and industrial plants.



Features

- Meets NFPA 58 requirements for liquid transfer
- Stainless steel screen
- Vent valve available in brass or stainless steel



5769HVB

Materials

Body Brass
 Screen Stainless Steel
 Gasket Resilient Rubber

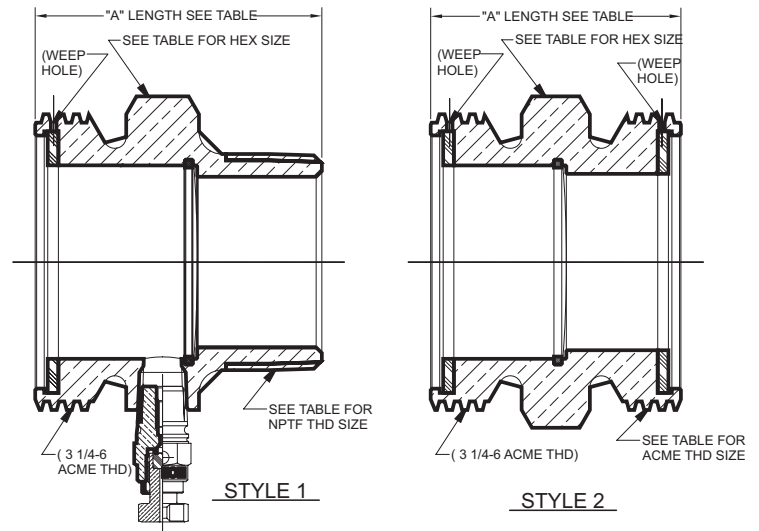

Ordering Information

Part Number	Style	Gasket Qty	Vent Valve	Hex Size	Thread	"A" Length
5769H	1	1	-	3/4"	2" M.N.P.T	2.875
5769K	1	1		3/2"	3" M.N.P.T	3.625
5769M	2	2		3/4" ACME	2.750	
5769HVB	1	1	3165CBT	3/4"	2" M.N.P.T	3.150
5769VSS	1	1	TSS3169			3.150

Low Emission ACME Connector For Transports and Bobtails 6588LE & 6589LE

Application

Designed to provide fast filling of bobtails, transports and large bulk storage tanks while providing for low emission of LPG when disconnecting.

Features

- 3/4" Male Acme Connector with reduced emissions, 90% less than current RegO ACME adapters.
- 10.5 cubic centimeters of liquid discharged at disconnect
- UL Listed as a Filler Valve.
- Safety groove is designed to shear below ACME threads leaving the valve seat closed and unaffected if the vehicle pulls away with the hose connected.
- Seat disc is made of synthetic composition and is mechanically held in place by a seat disc retainer.
- Stainless Steel return spring.
- One- piece poppet stem for smooth operation.
- Will connect to any standard female 3/4" ACME adapter.
- Hydrostatic relief valve included (3125L).

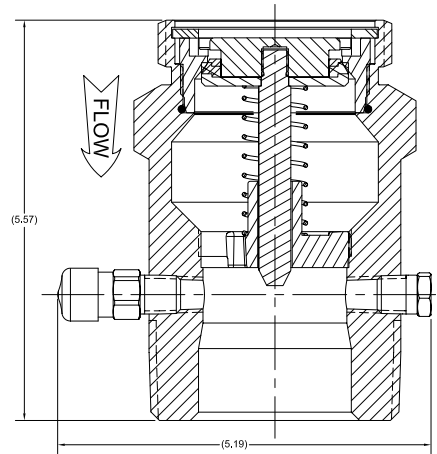

6588 Series

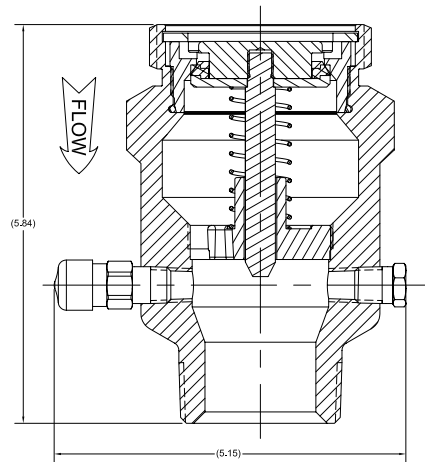

Materials

Upper Body.....	Brass
Lower Body.....	Brass
Poppet & Stem Assembly.....	Brass
Spring.....	Stainless Steel
Gasket.....	Resilient Synthetic Rubber
Seat Disc.....	Resilient Synthetic Rubber



Ordering Information

Part Number	ACME Connection	Outlet Connection M.NPT	Wrench Flats	Hydrostatic Relief Valve	Propane Capacity at Various Differential Pressures (GPM)		
					5 PSIG	10 PSIG	25 PSIG
6588LE	3/4"	2"	3 1/2"	3125L	138	223	349
6589LE	3/4"	3"		3125L			

Male POL Swivel Adapters

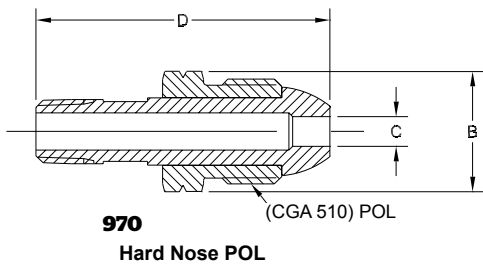

REGO
10
YEAR
WARRANTY

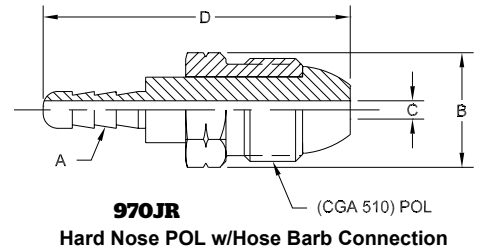
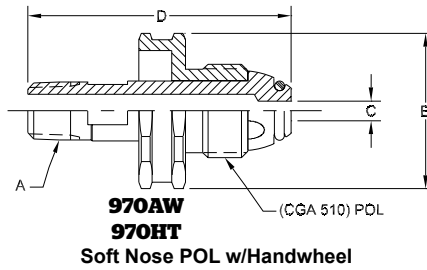
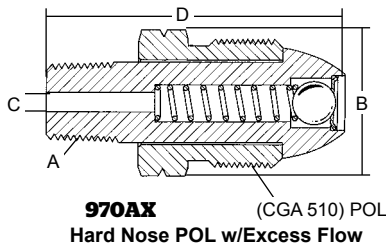
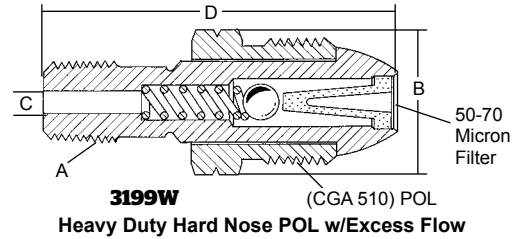
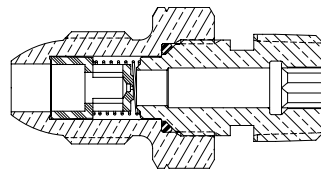
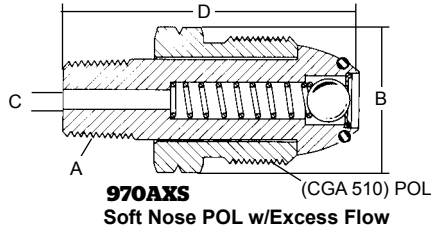
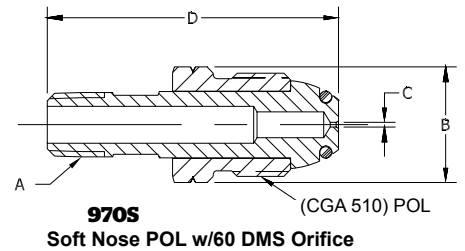

Ordering Information

Part Number	Material	A Outlet Thread	B Hex	C Drill	D Overall Length	Vapor at 100 PSIG Inlet (SCFH)	Liquid (GPM)	
970	Brass	1/4" M. NPT	7/8"	1/4"	2 15/32"	-	-	
970S				.040" orifice				
970AX				1/8"				
970AXS				5/32"				
970AWXS				3/16"				
3199W			1 3/8"	2 7/16"	450	0.95		
970AW			1 3/8"	2 15/32"	-	-		
970HT				.040" orifice				
970JR			1/4" Hose Barb	7/8"	5/32"	2 5/8"	-	-
3188A			1/2" M. NPT	1 1/8"	5/32"	2 1/2"	350	.95
3188B	700	1.9						
3188C	1180	2.9						

Note: All nipples incorporate wrench hex section.

CGA 555 Swivel Adapters

REGO
10
YEAR
WARRANTY

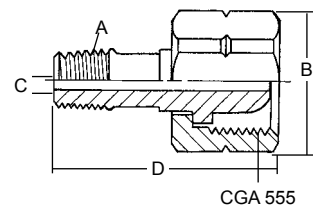

Ordering Information

Part Number	Material	A Outlet Thread	B Hex	C Drill	D Overall Length
12982	Brass	1/4" M. NPT	1 1/8"	3/16"	1 1/8"

POL Adapters

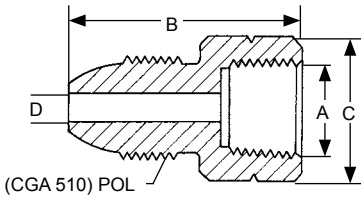

(CGA 510) POL
Male POL x Female NPT

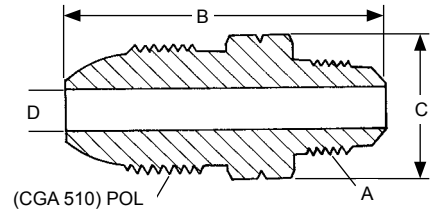

(CGA 510) POL
Male POL x Male NPT and SAE Flare

Ordering Information

Part Number	Material	A F.NPT	B	C Hex	D Diameter
2906A	Brass	1/4"	1 1/2"	7/8"	3/32"
2906G		1/2"	2"	1 1/8"	
2906E		3/4"	2 1/2"	1 3/8"	

Ordering Information

Part Number	Material	A	B	C Hex	D Diameter
2906D	Brass	3/8" M. NPT	2 5/64"	7/8"	1 1/32"
2906F		3/8" SAE Flare	2 3/32"		
2906E		1/2" SAE Flare	2 9/32"		3/32"

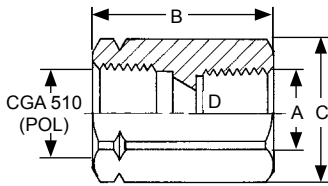

Female POL x Female NPT and Female POL

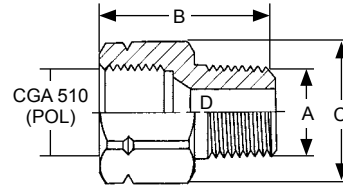

Female POL x Male NPT

Ordering Information

Part Number	Material	A	B	C Hex	D Diameter
5760A	Brass	1/4" F.NPT	1 5/8"	1 1/8"	13/32"
5760B		3/8" F.NPT			
5760C		1/2" F.NPT			
5760D		3/4" F.NPT			
5760S		POL (CGA 510)	2 1/8"	1 1/8"	13/32"

Ordering Information

Part Number	Material	A	B	C Hex	D Diameter
5761A	Brass	1/4" M.NPT	1 5/8"	1 1/8"	3/16"
5761B		3/8" M.NPT			13/32"
5761C		1/2" M.NPT			7/16"
5761D		3/4" M.NPT			7/16"

H

Hose Adapter
For use with fuel gases (LP-Gas, Acetylene).

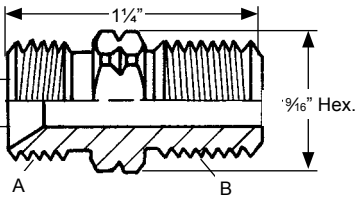

Ordering Information

Part Number	Material	A	B
1300	Brass	9/16"-18UNF (L.H.)	1/4" M. NPT

Ordering Information

Part Number	Material	A	B
15774-1	Brass	1/4" M. NPT	1/4" Female Inverted Flare

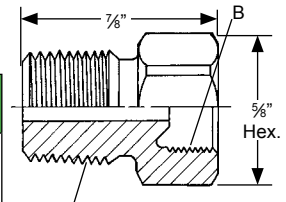

Female Inverted Flare x Male NPT

Pressure Gauge Adapter

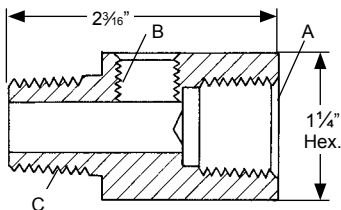

Ordering Information

Part Number	Material	A	B	C
1494-1	Brass	1/2" F. NPT	1/4" F. NPT	1/2" M. NPT

Ordering Information

Part Number	Material	A	B	C	D	E	F
1328	Brass	3/8" SAE Male Flare	3/8" SAE Female Flare	3/8" Hose Barb	13/16"	2"	1 1/8"
1331		1/2" SAE Male Flare	1/2" SAE Female Flare		1"	2 1/8"	1 1/4"
1332		5/8" SAE Male Flare	5/8" SAE Female Flare		1 1/8"	2 1/2"	

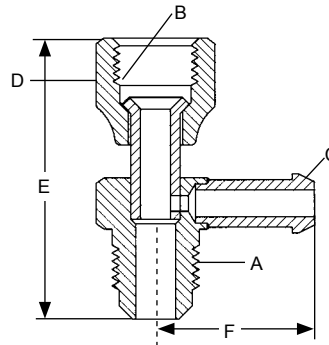

Copper Pigtails

Features

- Heavy duty construction.
- Individually soldered connections to the copper tubing.
- Each pigtail is individually tested prior to shipment.

Materials

Tubing..... Copper
Connections..... Brass



912JS12

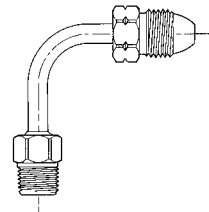

913JS05A

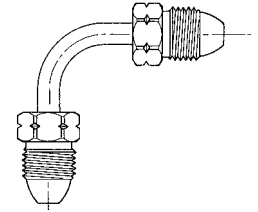

913PS05A

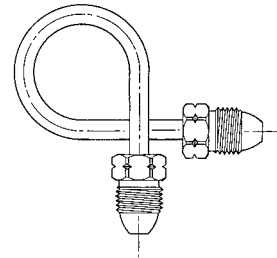

913PS12G

Straight Pigtails

Ordering Information

Connections	Approximate Length	Part Number		
		1/4" Tube		3/8" Tube
		3/8" Hex Short Nipple	1 1/8" Hex Long Nipple	3/8" Hex Short Nipple
M.POL x M.POL	5"	-	-	913PS05
	12"	912PS12	-	913PS12
	20"	912PS20	912PA20	913PS20
	30"	912PS30	-	913PS30
	36"	912PS36	912PA36	913PS36
	48"	912PS48	912PA48	913PS48
1/4" Inverted Flare x M.POL	12"	912FS12	-	-
	20"	912FS20	912FA20	-
	30"	912FS30	-	-
	36"	912FS36	-	-
1/4" M.NPT x M.POL	5"	-	-	913JS05
	12"	912JS12	-	913JS12
	20"	912JS20	912JA20	913JS20
	36"	912JS36	-	-
1/2" M.NPT x M.POL	12"	-	-	913LS12
1/2" M.NPT x 3/8" M.NPT	12"	-	-	913KL12

Bent Pigtails

Ordering Information

Connections	Approximate Length	Part Number		Type/Degree of Bend
		3/8" Tube		
		3/8" Hex Short Nipple		
1/4" M. NPT x M. POL	5"	913JS05A	913PS05A	90°
M. POL x M. POL	12"	913PS12G	913PS12S	270° Right Hand
		913PS12H		270° Left Hand
				360°

H

Section J
Miscellaneous Equipment
(Including Rotogages and ESVs)

J

Limited 10 Year Warranty and Limitation Of Liability

LIMITED 10 YEAR WARRANTY

RegO warrants to the original purchasers the products and repair kits manufactured by it to be free from defects in materials and workmanship under normal use and service for a period of 10 years from the date of manufacture. If within thirty days after buyer's discovery of what buyer believes is a defect, buyer notifies in writing and ships the product to RegO at 100 RegO Drive, Elon, NC 27244, RegO, at its option, and within forty-five days of receipt, will repair, replace F.O.B. point of manufacture, or refund the purchase price of that part or product found by RegO to be defective. Failure of buyer to give such written notice and ship the product within thirty days shall be deemed an absolute and unconditional waiver of any and all claims of buyer arising out of such defect.

This warranty does not extend to any product or part that is not installed and used after installation in accordance with RegO's printed instructions, all applicable state and local regulations, and all applicable national standards, such as those promulgated by NFPA, DOT and ANSI. This warranty does not extend to any product or part that has been damaged by accident, misuse, abuse, failure to maintain, or neglect, nor does it extend to any product or part which has been modified, altered, disassembled, or repaired in the field. This warranty does not cover any cosmetic issues, such as scratches, dents, marring, fading of colors or discoloration.

Except as expressly set forth above, and subject to the limitation of liability below, RegO MAKES NO OTHER WARRANTY, EXPRESS OR IMPLIED, INCLUDING, BUT NOT LIMITED TO, THE IMPLIED WARRANTIES OF MERCHANTABILITY AND FITNESS FOR A PARTICULAR PURPOSE, with respect to its products and parts, whether used alone or in combination with others. RegO disclaims all warranties not stated herein.

LIMITATION OF LIABILITY

RegO's total liability for any and all losses and damages arising out of any cause whatsoever shall in no event exceed the purchase price of the products or parts in respect of which such cause arises, whether such cause be based on theories of contract, negligence, strict liability, tort or otherwise.

RegO shall not be liable for incidental, consequential or punitive damages or other losses. RegO shall not be liable for, and buyer assumes any liability for, all personal injury and property damage connected with the handling, transportation, possession, further manufacture, other use or resale of products, whether used alone or in combination with any other products or materials.

From time to time buyers might call to ask RegO for technical advice based upon limited facts disclosed to RegO. If RegO furnishes technical advice to buyer, whether or not at buyer's request, with respect to application, further manufacture or other use of the products and parts, RegO shall not be liable for such technical advice or any such advice provided to buyer by any third party and buyer assumes all risks of such advice and the results thereof.

NOTE: Some states do not allow the exclusion or limitation of incidental, consequential or punitive damages, so the above limitation or exclusion may not apply to you. The warranty gives you specific legal rights, and you may have other rights that vary from State to State. The portions of this limited warranty and limitation of liability shall be considered severable and all portions which are not disallowed by applicable law shall remain in full force and effect.

WARNING

All RegO products are mechanical devices that will eventually become inoperative due to wear, corrosion and aging of components made of material such as rubber, etc. The environment and conditions of use will determine the safe service life of these products. Periodic inspection and maintenance are essential to avoid serious injury and property damage.

Many RegO products are manufactured components which are incorporated by others on or in other products or systems used for storage, transport, transfer and otherwise for use of toxic, flammable and dangerous liquids and gases. Such substances must be handled by experienced and trained personnel only, using accepted governmental and industrial safety procedures.

NOTICE TO USERS OF PRODUCTS

The Limited Warranty stated above is a factory warranty to the first purchasers of RegO products. Since most users have purchased these products from RegO distributors, the user must within thirty (30) days after the user's discovery of what user believes is a defect, notify in writing and return the product to the distributor from whom he purchased the product/part. The distributor may or may not at the distributor's option choose to submit the product/parts to RegO, pursuant to this Limited Warranty. Failure by buyer to give such written notice within thirty (30) days shall be deemed an absolute and unconditional waiver of buyer's claim for such defects. Acceptance of any alleged defective product/parts by RegO's distributor for replacement or repairs under the terms of RegO's Limited Warranty in no way determines RegO's obligations under this Limited Warranty.

Because of a policy of continuous product improvement, RegO reserves the right to change designs, materials or specifications without notice.

Foreword

This catalog describes a complete line of equipment available from RegO® for use with Liquid Propane (LP)-Gas and anhydrous ammonia (NH₃). The following points are important to know for proper use of the catalog:

1. Illustrations and drawings of individual products are representative of “product groups” and all products within a product group are similar in construction.
2. Materials used for construction of products in this catalog are suitable for rated service pressure at temperatures of -40°F to +165°F, unless otherwise specified.
3. Products in this catalog are only intended for use in LP-Gas and/or anhydrous ammonia service as follows.
 - a. “A” or “AA” prefix — Products with this prefix are suitable for NH₃ service (i.e., contain no brass parts).
 - b. “AA” prefix on relief valves — These valves are NOT suitable for use with LP-Gas service. These are of partial aluminum materials and are listed by Underwriters Laboratories (UL) for NH₃ service only.
 - c. All other products including “A” prefix are suitable for use with LP-Gas & NH₃ service.
 - d. “SS” prefix—Hydrostatic relief valve with this prefix are suitable for NH₃ and LP-Gas service (i.e., they have stainless steel materials).
4. We manufacture valves and adapters designed to be used on LP-Gas and Anhydrous Ammonia systems, we do not design systems or consult in system design. For this type of information consult a professional Engineer.

Caution

Do not use any product contained in this catalog with any service commodity other than LP-Gas or NH₃. If you have a need for use of another application, contact RegO, 100 RegO Drive, Elon, NC 27244, (336) 449-7707 ecii@regoproducts.com before proceeding.

Proper application, installation and maintenance of products in this catalog are essential. Users of these products should obtain further information if there are any doubts or questions.

Warning

All RegO products are mechanical devices that will eventually become inoperative due to wear, corrosion and aging of components made of materials such as rubber. The environment and conditions of use will determine the safe service life of these products. Periodic inspection and maintenance are essential to avoid serious injury and property damage.

Many RegO products are manufactured for storage, transport, transfer and use of toxic flammable and dangerous liquids and gases. Such substances should be handled by experienced and trained personnel only, using accepted governmental and industrial safety procedures. Never vent LP-Gas near any possible source of ignition.

Notice

Installation, usage, and maintenance of all RegO products must be in compliance with all RegO instructions as well as requirements and provisions of NFPA #54, NFPA#58, DOT, ANSI, and all applicable federal, state, provincial and local standards, codes, regulations, and laws.

Inspection and maintenance on a periodic basis is essential. Installation and maintenance should be performed only by qualified personnel.

Be sure all instructions are read and understood before installation, operation and service.

Filters

RegO LP-Gas equipment is designed to operate in a system free from contamination. A variety of in-line filters are commercially available to the LP-Gas industry for installation in domestic systems.

The use of an in-line filter should be considered when other system components may be unclean and the system contaminated by rust, scale, dirt, debris or other foreign material.

1" Rotogages® for Large Mobile and Stationary Containers

A9090 Series

Application

Rotogages® are designed to provide an accurate determination of LP-Gas or anhydrous ammonia container contents. They mount in a standard 1" NPT coupling on large mobile or stationary containers.

To operate the Rotogages®, the vent valve is opened and the dip tube rotated slowly from the container vapor space to the liquid space. The difference in appearance of the discharge indicates when the liquid level is reached. Dial readings then indicate the percentage of product in the container.

Features

- Supported design (TS Models) eliminates whipping and the need for internal support hangers.
- Resistance-free nylon bearing inserts reduce friction and promote operating ease.
- Dial face is dual calibrated to provide greater accuracy in reading contents in containers which are not level.
- Interchangeable accessory dials permit interchangeable service between LP-Gas and anhydrous ammonia.

Materials

Body	Steel
Stem	Steel
Dip Tube	Seamless Steel
Indicator.....	Malleable Iron
Dial Plate	Aluminium
Vent Stem	Stainless Steel

Tubes for use with A9090 Series Rotogages
Cut to length required.

Service	Part Number
Up to 48"	A9091-M24.0
Up to 72"	A9091-M36.0
Up to 96"	A9091-M48.0
Up to 120"	A9091-M60.0
Up to 144"	A9091-M72.0



Rotogage® Dials

Ordering Information

Part Number	Service	Container Size
A9091-18L	LP-Gas	All Sizes
A9091-18LX*	LP-Gas	Over 1200 U.S. gallons
A9091-18N	NH3	All Sizes

* Dial permits higher filling level, per NFPA 58.



Rotogage® Assembly



A9091-18LX

1" Rotogages® for Large Mobile and Stationary Containers

For Small Mobile or Stationary Containers
A9091R and A9092R Series

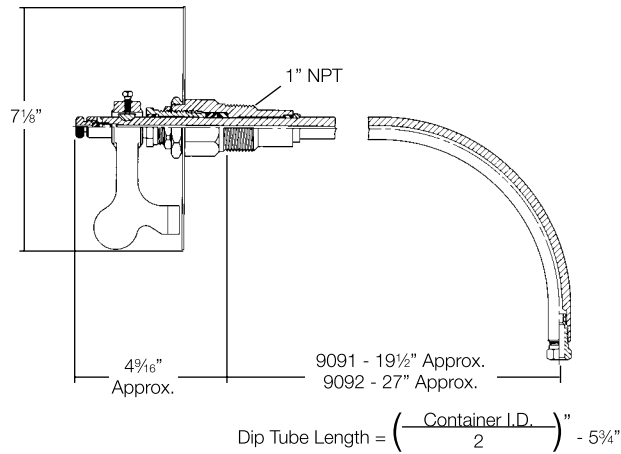

For Large Stationary Containers
9093RS, 9094RS and 9095RS Series

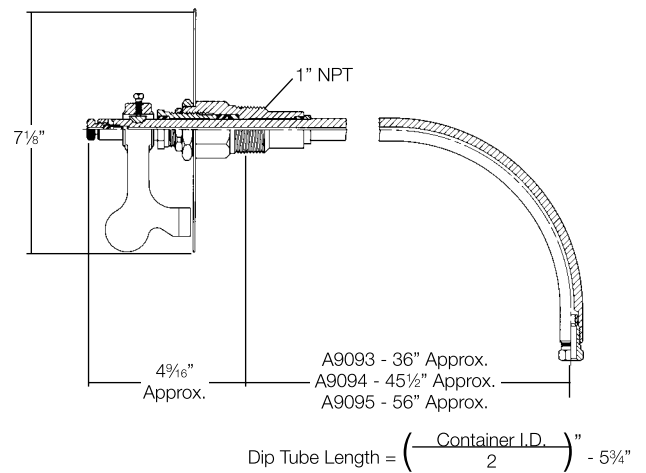

For Large Mobile or Stationary Containers
A9093TS, A9094TS and A9095TS Series

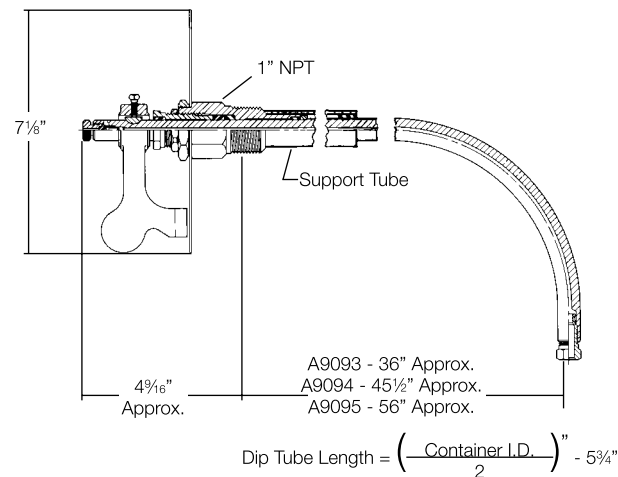

Ordering Information

Part Number		For Container Inside Diameter			
		Ellipsoidal Heads		Hemispherical Heads	
For Mobile or Stationary Containers	For Stationary Containers Only	Side Mounted	End Mounted	Side Mounted	End Mounted
A9091R	-	30" - 45"	30" - 75"	30" - 45"	30" - 45"
A9092R	-	46" - 61"	76" - 108"	46" - 61"	46" - 61"
A9093TS*	A9093RS	62" - 79"	109" - 147"	62" - 79"	62" - 79"
A9094TS*	A9094RS	80" - 99"	-	80" - 99"	80" - 99"
A9095TS*	A9095RS	100" - 147"	-	100" - 147"	100" - 147"

* Supported Design
NOTE: The dip tube must be cut to the required length (1/2" of container inside diameter minus 5 3/4").

3/4" Rotogages® for Small Stationary and Mobile LP-Gas Containers 2070 Series

Application

Rotogages® are designed to provide accurate determination of LP-Gas container contents. They may be end or side mounted in a standard 3/4" NPT coupling on stationary or mobile containers. To guarantee accurate measurement, they should not be used on stationary containers that exceed 60" I.D. or on mobile containers, subject to vibration, with an I.D. of more than 24".

Features

- Provides long, trouble-free performance and ease of operation.
- Polished stems ensure bind-proof operation.
- Dial face is dual calibrated to provide greater accuracy in reading contents in containers which are not level.

Materials

Body Brass
 Stem Brass Tubing
 Dip Tube Seamless Brass Tubing
 Dial Plate Aluminium
 Indicator Malleable Iron



2070 Series

2070 Series Rotogage® Mounting Positions

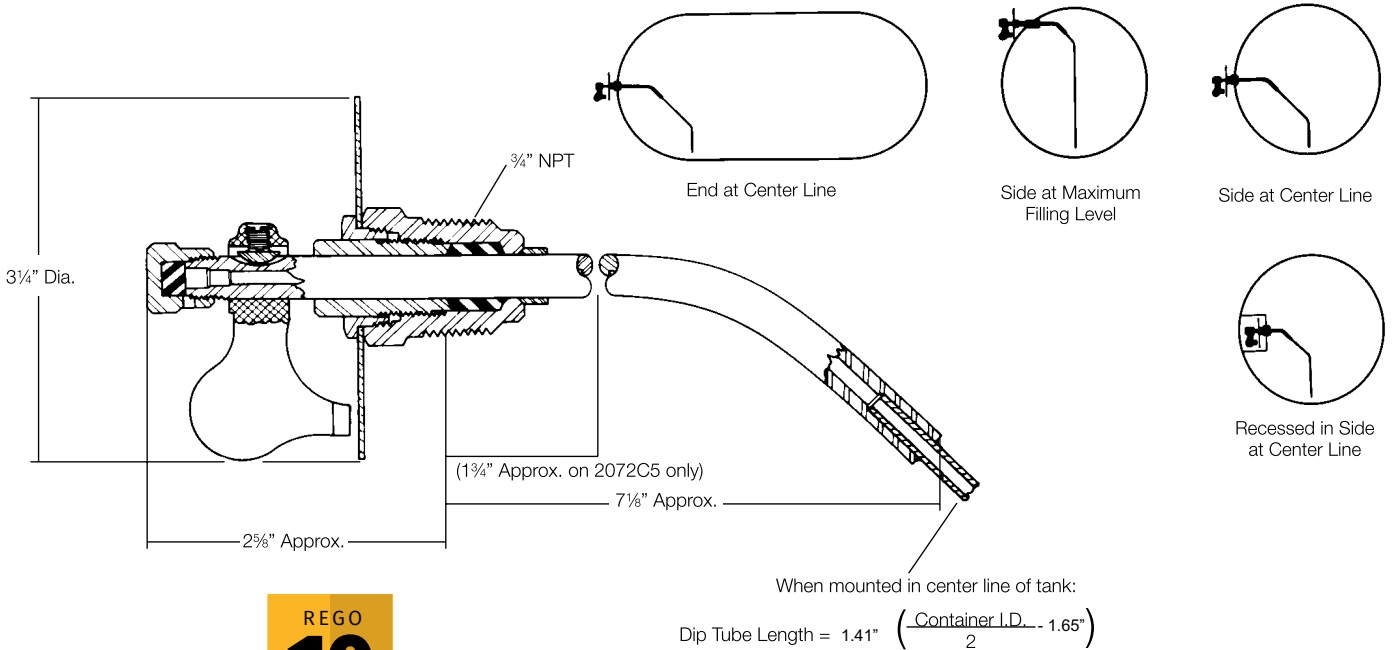

Ordering Information

Part Number		For Containers with Inside Diameter	Tank Connection	Valve Seat Orifice
Rotogage®	Dip Tube			
2070C0	2071-L25.7	Up to 40"	3/4 M. NPT	No. 54 Drill Size
	2071-L39.7	Up to 60"		

NOTE: The dip tube must be cut to the required length (1/2 of container inside diameter minus 1/2"), when mounted on center line of tank.

Pull-Away Valves for Transfer Operations

A2141 Series

Application

Designed especially to provide pull-away protection for LP-Gas and anhydrous ammonia transfer operations including transport and delivery truck loading and unloading, engine fuel container filling and miscellaneous cylinder filling operations. When properly fastened to the inlet end of the discharge hose, the valve is designed to stop gas escape from both upstream and downstream lines in the event of a pull-away. An excessive tension pull causes the valve to automatically separate, closing two internal back pressure checks. Only a few cubic centimeters of gas escape at the instant of separation.

It is recommended that a convenient means be provided to safely remove the pressure from the line upstream of each coupling half to enable reassembly of the valve. To reassemble, simply push the male half firmly into the female half until the retaining balls slip into the retaining groove. Check for leaks after reassembly.

NOTE: It is recommended that pull-away valves be maintained and safety tested periodically to confirm that they will separate properly in the event of a pull-away. Lubrication every six months is essential to the pull-away's operation. Dry nitrogen or other inert gas is suggested as a source of pressure for pull-away tests.

If the A2141 pull-away valve is going to be stored for a period of time, A2141 Series such as in seasonal applications, it is recommended that it be sprayed with a good grade of rust-preventive machine oil, and covered to protect it from moisture.

Features

- Heavy-duty construction for long service life.
- A "true" pull-away type valve which simply reconnects by snapping together without unnecessary downtime or need for new parts.
- Buna-N seals provide leak tight operation.
- 400 PSIG operating pressure.

Materials

Body (¾", 1")..... Cadmium Plated Steel
 Body (1¼", 2")..... Cadmium Plated Steel
 Seals..... Buna-N Rubber
 Cables Nylon Coated, Galvanized Steel



A2141A6



A2141A10

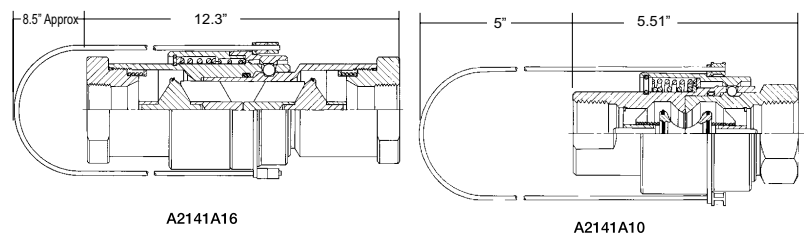
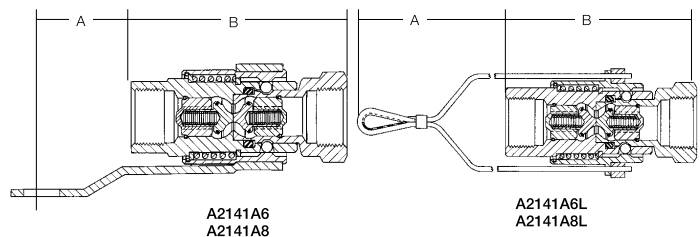

Ordering Information

Part Number	Inlet/Outlet Connections NPT F.	Disconnect Force Approx-lbs	Reconnect Force Approx-lbs	Length Of Valve	LP-Gas Liquid Flow Capacity at Various Differential Pressures (GPM)*			
					5 PSIG	10 PSIG	25 PSIG	50 PSIG
A2141A6	¾"	130	80	3⅞"	11	16	25	36
A2141A6L**								
A2141A8	1"	75	50	4⅞"	21	30	47	67
A2141A8L**								
A2141A10	1¼"	160	25	5⅞"	52	75	120	170
A2141A16	2"	300	50	14⅞"	250	350	550	750

* To Determine NH₃ liquid flow capacity, multiply by .90.

LP-Gas Emergency Shut-Off Valves (ESV's)

Why and how they should be used for Bobtail Filling and Transport Unloading.

General Information

The primary purpose of Emergency Shut-Off Valves in bobtail filling and transport unloading is to allow quick shut-off of liquid and vapor flow in the event there is an accidental pull-away of a truck or a hose rupture, both of which could cause a fire.

A system using Emergency Shut-Off Valves will not prevent some spillage of liquid and vapor, but the total system should be constructed so this spillage will be kept to a minimum.

This can be accomplished either by making possible, quick action by the driver or plant personnel in closing the valves by manual remote or pneumatic remote actuation; or in case of a pull-away, by automatic closing of the liquid valve by means of a cable connected to the liquid hose.

By minimizing the presence of liquid and vapor, the chance of a fire or explosion will be reduced. In case of a fire, thermal links at the valves or at other appropriate locations could close the valves and prevent further release of liquid and vapor.

The valve closing systems will be discussed later in this section. The user should decide which system is most appropriate, depending on the piping configuration and the general layout of the filling/unloading area.

ESV Application for Bobtail Loading and Transport Unloading

A very important function of the typical LP-Gas storage plant is to transfer LP-Gas into bobtails for delivery to customers. How efficiently and rapidly these bobtails can be filled often determines the number of customers that can be served each day, as well as how many bobtails are required to satisfactorily serve all customers. Therefore, the selection of an ESV for the bobtail liquid loading line should be done with care so as to maximize efficiency in filling and have year-round dependability.

The RegO 2" (A6016) and 3" (A6024) liquid ESVs have a full open port so that the restrictions of flow would be no more than you would expect through an equivalent length of schedule 80 pipe. To improve the overall efficiency of the system, the valves were designed as an operating valve so it could replace an existing globe or angle valve already installed at the end of the fixed piping. Thus, installing a RegO ESV could actually result in a more efficient pumping operation than the existing system.

Equally important in the consideration of an ESV is its performance in an emergency, especially bobtail pull-aways. Therefore, when selecting the proper ESV for bobtail filling, also consider the dependability of performance, and simplicity of operation and maintenance.

The RegO ESVs clearly indicate to the operator its open or closed position. It allows full manual control by the operator and provides means for remote operation in emergencies from either in front of the valve or in the rear.

No complicated systems of pulleys and cables are necessary since direct, straight pulls will close the valve. Means are even provided to secure a length of cable to the transfer hose so as to produce an automatic closing in the event the driver pulls away without disconnecting the hose.

NFPA Provisions (2014)

The pertinent provisions of NFPA Pamphlet 58, as they apply to Emergency Shut-Off Valves and how they are to be installed are below (for complete information refer to NFPA 58):

Section 5.12.2.3 requires that emergency shutoff valves be approved and incorporate all the following means of closing: (1) Automatic shutoff through thermal (fire) actuation, (2) Manual shutoff from a remote location, (3) Manual shutoff at the installed location.

Section 5.12.2.4 states where fusible elements are used; the melting point cannot exceed 250°F (121°C).

This provision sets for the basic criteria for the emergency shutoff valve, a key valve in the protection of many liquid transfer operations. Actuating means for remote control may be electrical, mechanical or pneumatic.

Many systems use a pneumatic system where the tubing itself acts as a fusible element releasing the pressure holding the valve open. With respect to the feature of manual shutoff at the installed location, it is recommended that this valve be operated occasionally. Also, the system should be tested periodically to determine that it will function properly.

Section 6.12.1 covers new and existing installations, stationary container storage systems with an aggregate water capacity of more than 4000 gal (15.1m³) utilizing a liquid transfer line that is 1½ in. (39 mm) or larger and pressure equalizing lines 1¼ in (32 mm) or larger, must be equipped with emergency shutoff valves.

Section 6.12.2 describes where an emergency shutoff valve must be installed in the transfer lines of the fixed piping transfer system within 20 ft (6m) of lineal pipe from the nearest end of the hose or swivel-type piping connections.

Section 6.12.5 covers installations where there are two or more liquid or vapor lines with hoses or swivel-type piping connected of the sizes designated in 6.12.1, an emergency shutoff valve or a backflow check valve, where allowed, must be installed in each leg of the piping.

Section 6.12.6 states the requirements for thermal protection; emergency shutoff valves must be installed so that the temperature-sensitive element in the valve, or a supplemental temperature-sensitive element that operates at a maximum temperature or 250°F (121°C) that is connected to actuate the valve. It also states maximum distance this can be which is not more than 5ft (1.5m) from the nearest end of the hose or swivel-type piping connected to the line in which the valve is installed.

Section 6.12.7 requires that the temperature-sensitive elements of emergency shutoff valves cannot be painted, or can they have any ornamental finishes applied after manufacture.

Section 6.12.8 emergency shutoff valves or backflow check valves must be installed in the fixed piping in manner to protect them so that any breaks resulting from a pull will occur on the hose or swivel-type piping side of the connection; allowing the valves and piping on the plant side of the connection to remain intact.

Section 6.12.9 emergency shutoff valves that are required to be installed in accordance with 6.12.2, that a means must be incorporated to actuate the emergency shutoff valves in the event of a break of the fixed piping resulting from pulling of the hose.

Section 6.12.10 states that all emergency shutoff valves required by the code be annually tested for the functions required in 5.12.2.3 (2) Manual shutoff from a remote location, (3) Manual shutoff at the installed location; the results of the test are documented.

Section 6.12.12 requires that new and existing emergency shutoff valves shall comply with 6.12.12.1 through 6.12.12.3 below.

Section 6.12.12.1 requires that the emergency shutoff valve shall have at least one clearly identified and accessible manually operated remote shutoff device.

Section 6.12.12.2 states that the remote shutoff device for an emergency shutoff valve must be located not less than 25ft (7.6m) or more than 100 ft. (30 m) in the path away from the emergency shutoff valve.

Section 6.12.12.3 describes the requirements when an emergency shutoff valve is used in place of an internal valve in compliance with 5.7.4.2(D) (2) the remote shutoff device have to be installed in accordance with 6.11.4 and 6.11.5.

The provisions above and others covered in NFPA 58 can assist in determining how bobtail filling and transport unloading stations are to be configured. The diagrams shown here offer general information, they should not be used as an installation guide.

LP-Gas Emergency Shut-Off Valves (ESV's)

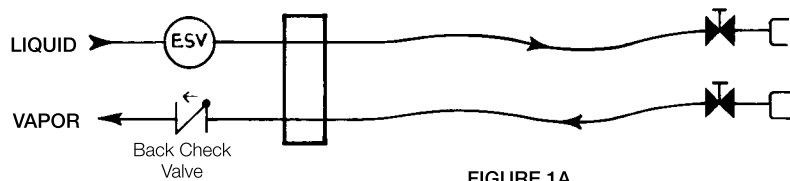

FIGURE 1A
Bobtail Filling Only

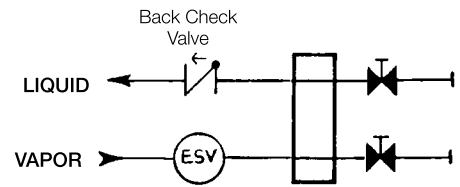

FIGURE 1B
Transport Unloading Only

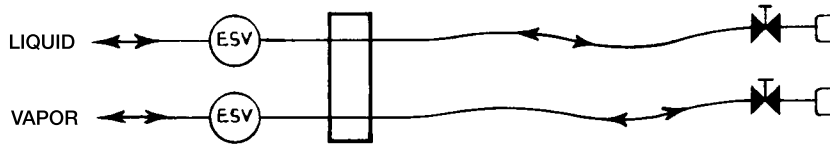

FIGURE 1C
Combined Bobtail Filling
and Transport Unloading

Installation Compliance with NFPA Requirements

A valve that is approved as an ESV may be installed in the fixed piping up to a distance of 20 feet (along the pipe) from the point where the transfer hose is attached to the fixed piping.

However, when the ESV is located more than five feet from the end of the fixed piping, an additional fusible element must be installed within five feet of the point of attachment of the hose, and be connected to the ESV valve in such a manner that it will cause the ESV to close in the event of a fire.

The ideal location of the ESV is as close to the end of the fixed piping as possible. This position eliminates the need for an additional fusible element and cable, and it may also permit the elimination of a restrictive valve already installed at the end of the fixed piping.

To this point, our comments have been principally concerned with ESV protection of the liquid line at bulk plants because this is the area of greatest potential danger in the event of a pull-away or hose rupture.

However, regulations also require an ESV in the vapor transfer line when the vapor hose is 1¼" or larger. A helpful rule of thumb in determining whether or not an ESV control valve is required in your

vapor system is this: If the vapor flow is out of the storage tank, an ESV is required. ESV systems are designed to protect the storage tank contents against uncontrolled release.

Therefore, a bobtail loading system could use a 1¼" or larger back pressure check valve in the vapor system since the flow of vapor is always from the bobtail being filled back to the storage tank. To improve transfer rates, the use of the RegO 6586D back check valve at this location would provide protection at minimum pressure drop.

If the bobtail vapor line is also used when unloading transports, then the RegO A6010 ESV should be used. The A6010 provides thermal protection, manual closing and a remote emergency closing system similar to the RegO 2" liquid ESV, A6016.

Remote Control Systems

Usually in transfer loading operations, the valve handles and cables are located in close proximity to the area of greatest potential danger during an emergency. Therefore, each bobtail filling system or transport unloading system should have installed in it at least one readily accessible, alternate remote operating device.

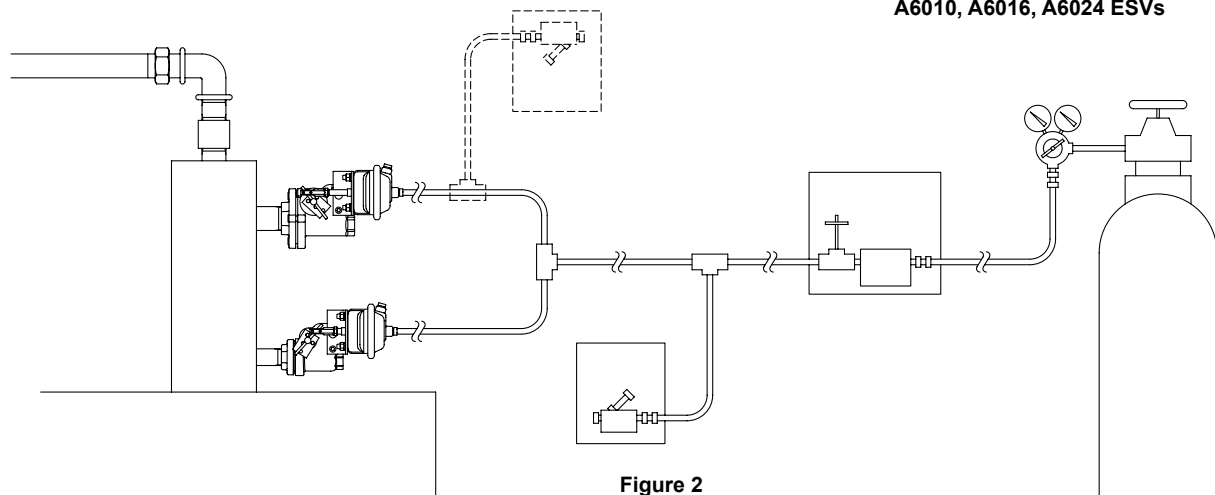

Figure 2
RegO ESV's with Remote Pneumatic
and Transfer Hose Cable Release
Systems Typical Installation

A6010, A6016, A6024 ESVs

2" & 3" Swing-Check ESVs for Bulk Plants A6016 Series and A6024 Series

Application

Designed for installation in liquid transfer lines at LP-Gas or Anhydrous Ammonia bulk plants to provide for quick shut-off of liquid or vapor flow in the event of an accidental pull-away, line break, or hose rupture.

Features

- Fusible Element is located in the thermal fuse assembly which acts at the latch open and close trigger. When exposed to fire, the element melts at 212° F allowing the shaft to return to the closed position.
- Valve can be opened by use of operating lever, if a pneumatic actuator is used it will open with the actuator.
- Valve can be closed by remote cable or pneumatic actuator.
- Valve can be closed by simply pushing the operating lever down, it is not necessary to trip the close trigger.
- Seat Disc is retained by a metal seat to minimize leakage in case of direct fire impingement.
- Quick closing regardless if the pump is running or not.

Sturdy Rugged Construction

- Will withstand hydraulic shock of sudden closings, piping strains, and temperature variations.
- Valve has only two moving parts, stem and close/thermal trigger.
- A6016 is UL listed for use in LP-Gas as an emergency and operating shut-off valve.
- Stem seals are spring loaded for leak free performance at low temperatures/pressures.

Materials

Body Ductile Iron Cad Plated
 Stem Stainless Steel
 Seat Stainless Steel
 Seat Disc (VA6016/VA6024) High Temperature Viton
 Seat Disc (A6016/A6024) Nitrite
 Springs Stainless Steel
 Gaskets Teflon



A6016

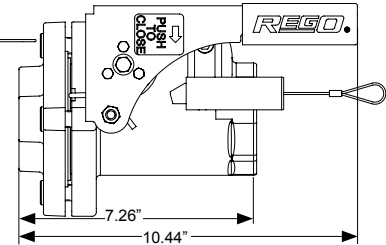
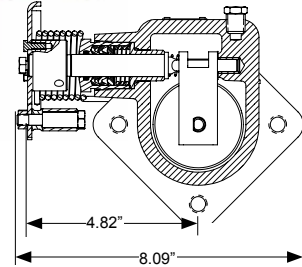
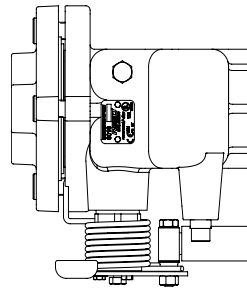

A6024

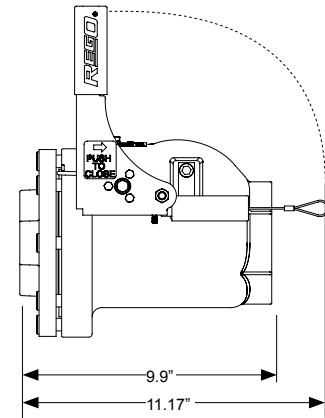
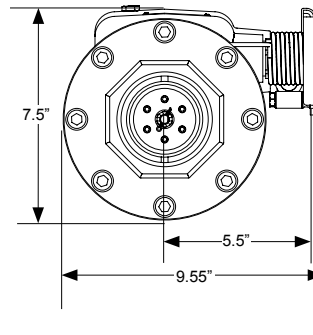
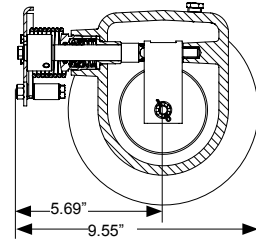

Ordering Information

Part Number	Seat	Inlet and Outlet Connections	Liquid Flow Capacity at 10 PSIG Drop (GPM)	Accessories		
				Remote Close Pneumatic	Remote Open/Close Pneumatic	Remote Open/Close Rotary
VA6016	Viton	2" F.NPT	711 (LP-Gas)	6016-60D	6016-60C	6016RA
A6016	Buna-N	2" F.NPT	640 (NH ₃ or LP-Gas)			
VA6024	Viton	3" F.NPT	1325 (LP-Gas)			
A6024	Buna-N	3" F.NPT	1173 (NH ₃ or LP-Gas)			

1¼" Swing-Check ESV for Bulk Plants VA6010 and A6010

Application

Designed for installation in liquid or vapor transfer lines at LP-Gas or Anhydrous Ammonia bulk plants to provide for quick shut-off of liquid or vapor flow in the event of an accidental pull-away, line break, or hose rupture.

Features

Meets NFPA 58 and UL requirements

- Fusible Element is located in the thermal fuse assembly, which acts at the latch open and close trigger. When exposed to fire, the element melts at 212 degrees F. allowing the shaft to return to the closed position.
- Valve can be opened by use of operating lever. If a pneumatic actuator is used it will open with the actuator.
- Valve can be closed by remote cable or pneumatic actuator.
- Valve can be closed by simply pushing the operating lever down; it is not necessary to trip the close trigger.

Sturdy Rugged Construction

- Will withstand hydraulic shock of sudden closings, piping strains, and temperature variations.
- Valve has only two moving parts, stem and close/thermal trigger.
- **A6010** is UL listed for use in LP-Gas as an emergency and operating shut-off valve.
- Stem seals are spring loaded for leak free performance at low temperatures/pressures.
- Seat Disc is retained by a metal seat to minimize leakage in case of direct fire impingement.
- Quick closing regardless if the pump is running or not.

Materials

Body Ductile Iron Clad Plated
 Stem Stainless Steel
 Seat Stainless Steel
 Seat Disc High Temperature Viton (6010 only)
 Seat Disc Synthetic Rubber (AA6010 only)
 Springs Stainless Steel
 Gaskets Teflon



A6010

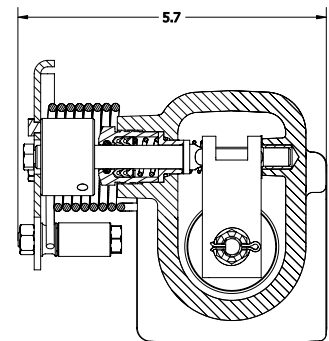
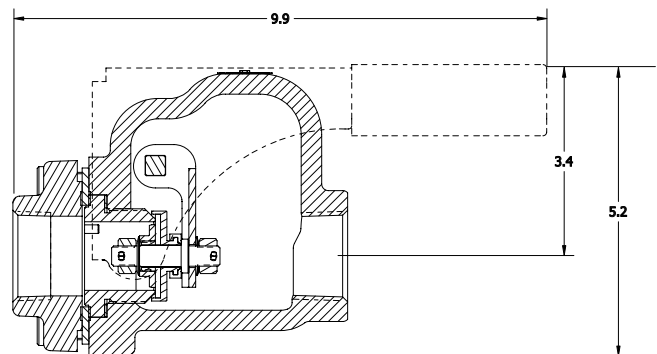

6016-60D



6016RA



6016-60C

Ordering Information

Part Number	Seat	Inlet and Outlet Connections	Accessories			Liquid Flow Capacity @ 10 PSIG Pressure Drop (GPM)
			Remote Pneumatic Close	Remote Pneumatic Open/Close	Rotary Actuator	
VA6010	Viton	1¼" F. NPT	6016-60D	6016-60C	6016RA	259 (LP-Gas)
A6010	Buna-N	1¼" F. NPT				233 (NH ₃ or LP-Gas)

Flanged ESVs for Bulk Plants

FA6010, FA6016 and FA6024

Application

Designed for installation in liquid transfer lines at LP-Gas or Anhydrous Ammonia bulk plants to provide for quick shut-off of liquid or vapor flow in the event of an accidental pull-away, line break, or hose rupture.

Features

- Fusible Element is located in the thermal fuse assembly which acts at the latch open and close trigger. When exposed to fire, the element melts at 212° F allowing the shaft to return to the closed position.
- Valve can be opened by use of operating lever, if a pneumatic actuator is used it will open with the actuator.
- Valve can be closed by remote cable or pneumatic actuator.
- Valve can be closed by simply pushing the operating lever down. It is not necessary to trip the close trigger.
- Seat Disc is retained by a metal seat to minimize leakage in case of direct fire impingement.
- Quick closing regardless if the pump is running or not.

Sturdy Rugged Construction

- Will withstand hydraulic shock of sudden closings, piping strains, and temperature variations.
- Valve has only two moving parts, stem and close/thermal trigger.
- UL listed for use in LP-Gas as an emergency and operating shut-off valve.
- Stem seals are spring loaded for leak free performance at low temperatures/pressures.

Materials

Body Ductile Iron Cad Plated
 Stem Stainless Steel
 Seat Stainless Steel
 Seat Disc (FVA6010/16/24) High Temperature Viton
 Seat Disc (FA6010/16/24) Nitrile
 Springs Stainless Steel
 Stem Seals Teflon

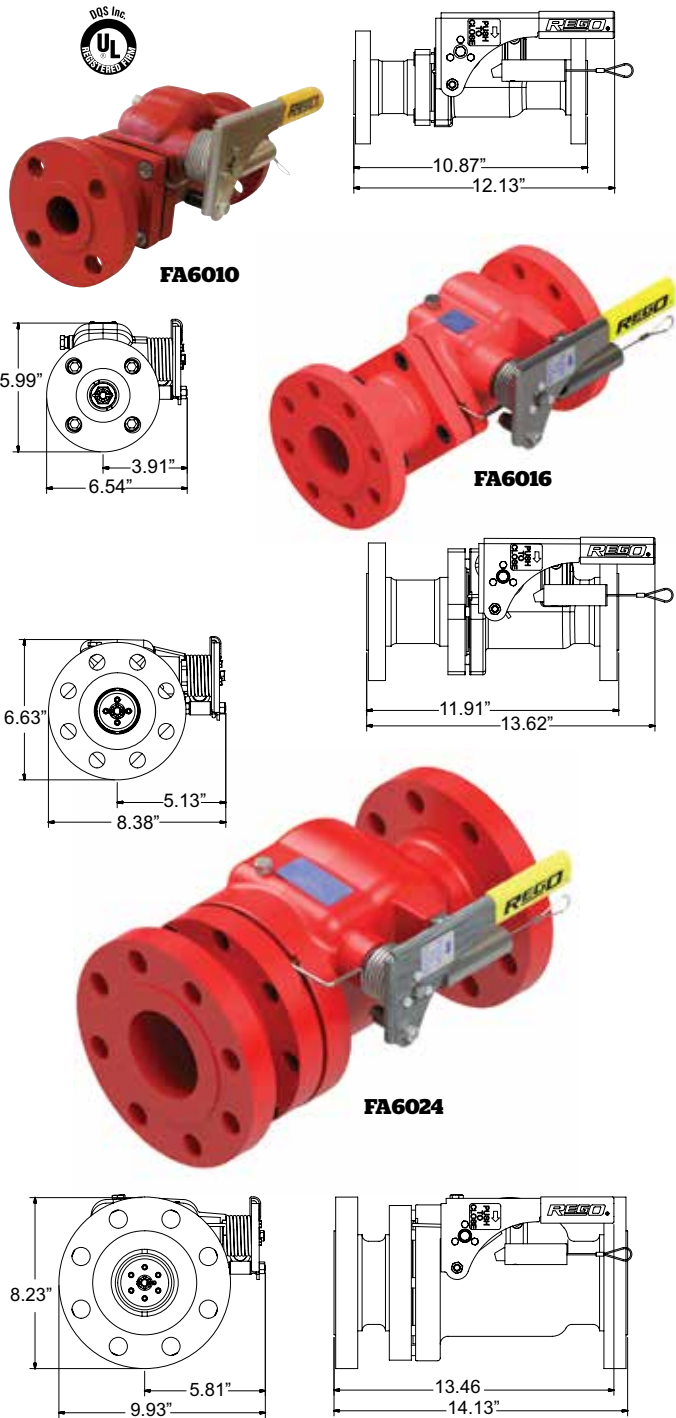

Ordering Information

Part Number	Seat	Inlet and Outlet Connections	Liquid Flow Capacity at 10 PSIG Drop (GPM)	Accessories		
				Remote Close Pneumatic	Remote Open/Close Pneumatic	Remote Open/Close Rotary
FVA6010	Viton	1¼" - 300# ANSI RF Flange	233 (NH ₃)	FA6016-60D	*	6016RA
FA6010	Buna-N	1¼" - 300# ANSI RF Flange	259 (LP-Gas)			
FVA6016	Viton	2" - 300# ANSI RF Flange	640 (NH ₃)			
FA6016	Buna-N	2" - 300# ANSI RF Flange	711 (LP-Gas)		6016-60C	
FVA6024	Viton	3" - 300# ANSI RF Flange	1173 (NH ₃)			
FA6024	Buna-N	3" - 300# ANSI RF Flange	1325 (LP-Gas)			

* Not Available

ESV Pneumatic Controls

Application

RegO Emergency Shut-Off Valves modified for remote pneumatic shutdown operation retain all the operating features of the standard valves.

Once equipped with pneumatic cylinders and then pressurized, the pneumatic cylinder piston rod disengages from a striker plate, allowing the ESV to be manually opened and the striker plate to act as a latch and hold the valve open. Release of the control system pressure for any reason closes the ESV for fail-safe operation.

Features

Convenience

- Closes the liquid and vapor ESV from a convenient remote location.
- Independent closed loop system allows the ESV to be pneumatically charged, but opened or closed manually or with cable controls to conserve pressurized gas.

Reliability

- Independent closed loop system will continue to hold pressure and close ESV in an emergency - even if supply pressure is cut off.

Security

- Any loss of pressure from the control line, such as accidents or the line melting from fire, automatically shuts down the liquid and vapor ESV.
- ESV must be reset after automatic shutdown.

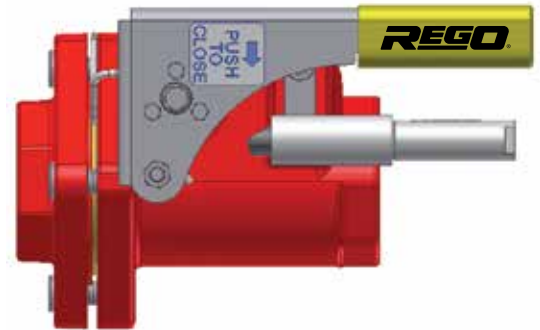

A6016 with 6016-60D Remote Close Actuator



6016PN-50 Pneumatic Remote Control Kit

Control kit with components for connecting and charging the pneumatic controls from a source of compressed gas (air or nitrogen) to a RegO liquid or vapor ESV. Includes charging valves with low pressure indicator, operating valves, 100 feet of 1/4" plastic tubing and tube fittings.

Ordering Information

Part Number	Description
6016-60D	Cylinder assembly kit to convert 6016 ESVs to pneumatic shutdown.
6016PN-50	Pneumatic remote shutdown system kit, complete with 100' of tubing, fittings, 1 charging valve assembly and 1 remote shutdown valve assembly
6016PN-80	Bypass kit for pneumatic actuators.
7605A-BT	100' roll of 1/4" pneumatic tubing.
7605AP-16	1/4" tubing tee, with nuts.
7605AP-15	1/8" NPT x 1/4" tubing, straight connector.
7606RM	Remote Close Cable Kit

Hydraulic Automatic Cylinder Filling System 7194MD and 7194HD

Application

Designed to provide accurate, economical filling of LP-Gas, DOT and fork lift cylinders by weight. Filling stops automatically as the total weight of the cylinder reaches the amount pre-set on the scale. One individual can efficiently handle up to four cylinder filling operations simultaneously to maximize profits, increase efficiency and allow servicing of more customers.

The RegO automatic cylinder filling system is designed for use with these scales only:

FAIRBANKS-MORSE SCALES

New Style - 1280A Double Beam Scale or Single Beam Scales 1124A and 1174A.

Old Style - 1280 Double Beam Scale or Single Beam Scale 1123 with or without Howe No. 12108 "Over or Under" Indicator.

HOWE SCALES

(with or without Howe No. 8325 Balance Indicator)

—No. 54X Wood Pillar and Shelf Scale.

—No. 57 Steel Pillar and Shelf Scale (single beam).

—No. 57X Steel Pillar and Shelf Scale (double beam).

Features

- Completely self-contained with no electrical source or wiring required.
- Works hydraulically, like brakes on a car.
- Filling stops automatically when cylinders reach pre-set weight.
- Up to four stations can be handled by one individual.

How It Works

The scale beam weight is adjusted to the desired filled weight and the empty cylinder is placed on the scale. The loading hose is connected to the cylinder valve, and the lever on the master cylinder is moved to the vertical position. When the quick-acting valve on the loading hose is opened, the cylinder will rapidly fill. The master cylinder lever is designed to trip, move to a horizontal position and automatically shut off the control valve as soon as the scale reaches the pre-set filled weight.

Components may be ordered separately with piping done by the installer. Two completely assembled manifold configurations are also available.



Hydraulic self-contained system.
No external power required.

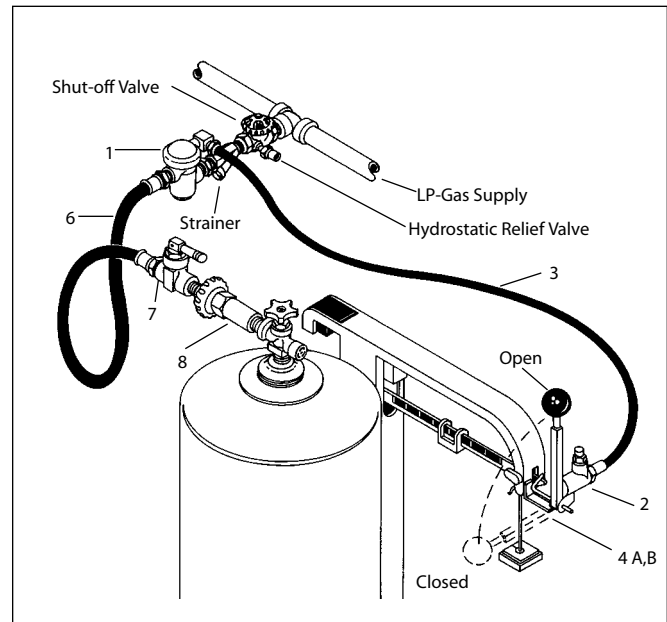

Ordering Information

Hydraulic System Components

Key No.	Description	Size	Part No.
Assembly for Fairbanks-Morse. Includes items 1 thru 8 below.			7194MD
Assembly for Howe. Includes items 1 thru 8			7194HD
1	Propane Control Valve	½" NPT Female, with ⅛" NPT Female Hydraulic Connection	7177
2	Master Cylinder, with Actuator Lever	⅝" NPT Hydraulic Connection	7188
3	Hydraulic Hose Assembly	⅜" I.D. with ⅝" NPT Male Ends, 43½" Overall Length	7194-1
1-3	Valve, Cylinder and Hose Assembly for Fairbanks-Morse Scales	-	7188MS
1-3	Valve, Cylinder and Hose Assembly for Howe Scales	-	7188HS
4A	Bracket Kit for Fairbanks Morse Scales, Complete with Screws, Washers, Nuts and Instructions	-	7194M-3A
4B	Bracket Kit for Howe Scales, Complete with Screws, Washers, Nuts and Instructions	-	7194H-3
5	Can of Hydraulic Fluid, Complete with Filling Spout	1½ ounce	7188-21
6	Propane Filling Hose Assembly	½" I.D., with ½" NPT Male Ends. 50½" Overall Length	7193D
7	Quick-acting Shut Off Valve	½" NPT Inlet X ¼" NPT Outlet	7901TB
8*	Soft Nose Cylinder Connector	¼" NPT Male X POL Male	7193D-10L

3" Heavy Duty Swing Check with Flow Indicator A7624

Application

This back check valve is designed to provide required back flow protection for the unloading riser in the bulk plant's transfer area. It is designed specifically for pipeline installation and is suitable for LP-Gas and anhydrous ammonia service. Product flow moves the swing check to the open position, when flow stops the spring loaded swing check closes.

Features

- Easy-to-read flow indicator
- Heavy duty spring loaded swing check design
- Resilient synthetic rubber seat disc
- High flow rates with low pressure drop
- May be installed either horizontally or vertically
- ¼" F.NPT plugged boss on top of body

Materials

Body Ductile Iron
 Stem Stainless Steel
 Seat Stainless Steel
 Seat Disc Resilient synthetic rubber
 Return Spring Stainless Steel



A7624

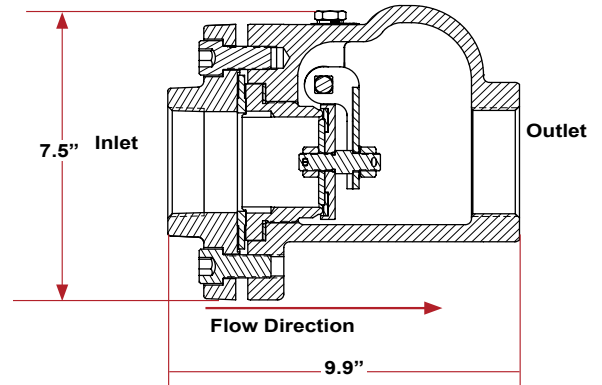

Ordering Information

Part Number	For Use With:	Inlet & Outlet Connections	Liquid Capacity at 10 PSIG Drop GPM
A7624	LPG & NH3	3" F.NPT	1325-GPM(LPG) 1173-GPM(NH3)

J

2" Heavy Duty Swing Check with Flow Indicator A7616

Application

This back check valve is designed to provide required back flow protection for the unloading riser in the bulk plant's transfer area. It is designed specifically for pipeline installation and is suitable for LP-Gas and anhydrous ammonia service. Product flow moves the swing check to the open position, when flow stops the spring loaded swing check closes.

Features

- Easy-to-read flow indicator
- Heavy duty spring loaded swing check design
- Resilient synthetic rubber seat disc
- High flow rates with low pressure drop
- May be installed either horizontally or vertically
- ¼" F.NPT plugged boss on top of body

Materials

Body Ductile Iron
 Stem Stainless Steel
 Seat Stainless Steel
 Seat Disc Synthetic Rubber
 Return Spring Stainless Steel



A7616

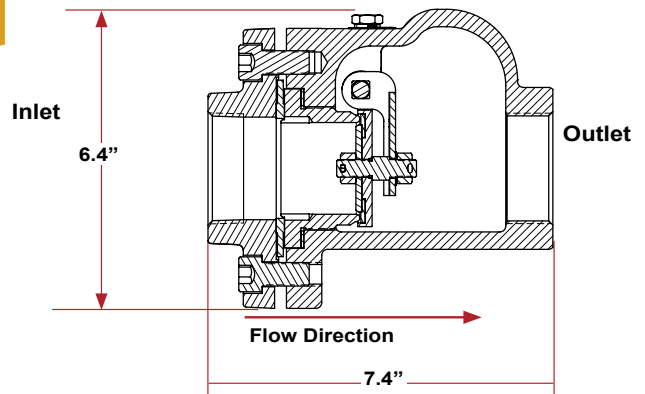

Ordering Information

Part Number	For Use With:	Inlet & Outlet Connections	Liquid Capacity at 10 PSIG Drop GPM
A7616	LPG & NH3	2" F.NPT	711-GPM(LPG) 640-GPM(NH3)

Sight Flow Indicators for Bulk Plants

A7794 and A7796

Application

Designed to promote maximum pump efficiency, these indicators enable bulk plant operators to visually inspect liquid flow conditions. With glass on both sides of the indicator, flow can be observed from either side, even under some poor light conditions. The integral swing check also serves as a back-check valve to prevent reverse flow and product loss if the hose fails in a loading operation.

By installing an indicator on the upstream side of the plant pump, suction conditions can be observed and the pump speed adjusted to obtain the maximum possible flow rate without cavitation. Additionally, if an indicator is installed in the piping at the loading rack, just ahead of the loading hose, the operator can maintain a constant check on pump conditions.

Both installations are designed to allow for observation to provide maximum pump efficiency and ensure safe plant pump operation.

In compressor operations a sight flow indicator installed in the liquid line will give a visual indication when the tank car or transport is emptied. Compressor operation can then be immediately reversed to start recovery of the vapor.

Features

- Durable ductile iron body ensures long, trouble-free operation with design working pressure of 400 PSIG.
- Glass is polished, ground and tempered after fabrication for maximum strength up to 2,500 PSIG.
- Set screws minimize loosening of glass retainer rings.
- O-ring glass seals provide for leak-tight operation.

Materials

Body Ductile Iron
 Swing Check..... Stainless Steel
 Check Seat Disc..... Resilient Synthetic Rubber
 Glass Polished, Ground, Tempered and tested to 2,500 PSIG

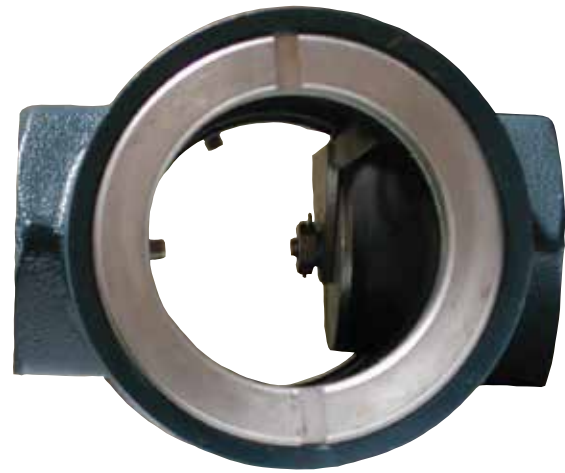

A7794

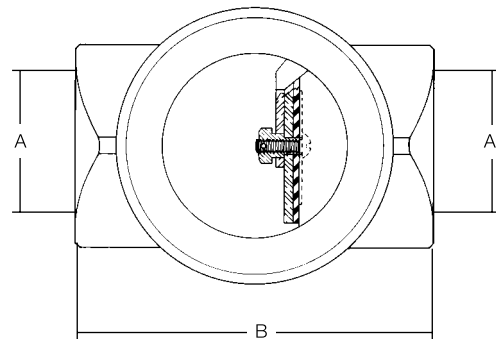

Ordering Information

Part Number	A Inlet/Outlet Connections	B Length
A7794	2" F. NPT	5 1/4"
A7796	3" F. NPT	7 3/8"

Hose End Adapters for DOT Cylinder Filling

7193D-10 and 7193U-10

Application

Designed to provide quick and easy filling of DOT cylinders with POL or Type I connections. This adapter may be used with hydraulic and electric automatic systems or with manual systems in conjunction with a RegO 7901TB Quick Acting Shut-Off Valve.

These filling connectors have an extended connection on the handwheel, which makes it possible to connect the loading hose to valves on cylinders with fixed collars. The handwheel is well outside the collar for easy operation.



7193D-10

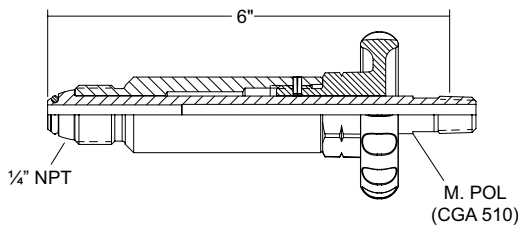

7193U-10

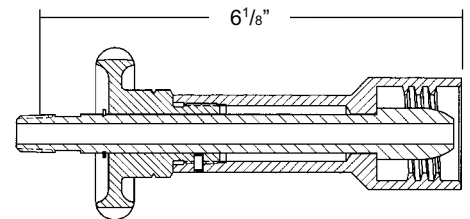

Part Number	Applications	Inlet Connection	Outlet Connection	Materials
7193D-10	Filling of DOT Cylinders with POL Connections	1/4" M. NPT	M. POL (CGA 510)	Brass & Stainless Steel
7193U-10	Filling of DOT Cylinders with Type I Connections		Type 1 Connection (1 5/16" F. ACME)	Brass

J

Connector for DOT Cylinder Filling Adapter

7193T-10

Application

The 7193T-10 Connector is designed for use on the 7193D-10 Filling Adapters. Connector allows quick connection to the Type I 1 5/16" M. ACME threads for operators that fill both POL and Type I valves.

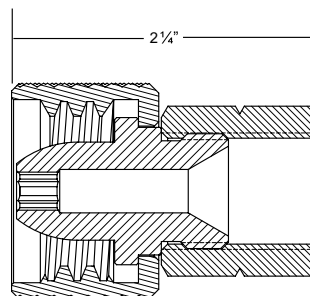

7193T-10

Ordering Information

Part Number	Applications	Inlet Connection	Outlet Connection	Materials
7193T-10	Converts 7193D-10 Adapters from POL to a Type 1 Connection	F. POL CGA 510	Type 1 Connection (1 5/16" F. ACME)	Brass

New Patented Low Emission Hose End Safety Adapter 7193D-10L

Application

Low Emission Adapter (1.18 cc at disconnect) designed to provide quick and easy filling of DOT cylinders with POL connections with minimal release of product on disconnect. This adapter may be used with dispensing systems in conjunction with RegO 7901T Series Quick Acting Shut-Off Valve. Balanced, light weight design for filling into 20 # - 200 # cylinders.

Features

- Meets CARB Low Emission Standards.
- Light weight, easy-to-use.
- Soft Nose M.POL connection.
- Redundant Safety Feature – will only open when connected to valve.

Materials

BodyBrass – Knurled
 ShaftStainless Steel – 1/4" M.NPT x M.POL (CGA 510)
 O-RingSynthetic Rubber



7193D-10L Series

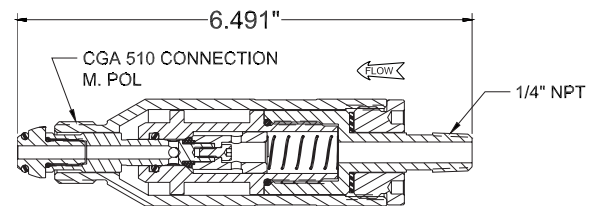

Ordering Information

Part Number	Application	Inlet Connection	Outlet Connection	Materials
7193D-10L	Filling of DOT cylinders with POL Connections	1/4" M. NPT	M. POL (CGA 510)	Brass & Stainless Steel

New Patented Low Emission Hose End Safety Adapter 7193U-10L

Application

Low Emission Adapter (1.18 cc at disconnect) designed to provide quick and easy filling of DOT cylinders with Type 1 connections with minimal release of product on disconnect. This adapter may be used for dispensing systems in conjunction with RegO 7901T Series Quick Acting Shut-Off Valve. Balanced, light weight design for filling into 20 # - 200 # Cylinders

Features

- Meets CARB Low Emission Standards
- Light weight, easy-to-use type 1 Fitting
- Liquid release directed away from operator
- Redundant Safety Feature – will only open when connected to valve.

Materials

BodyBrass - Knurled
 ShaftStainless Steel – 1/4" M.NPT x Type 1 (15/16" M. ACME)
 O-RingSynthetic Rubber



7193U-10L Series

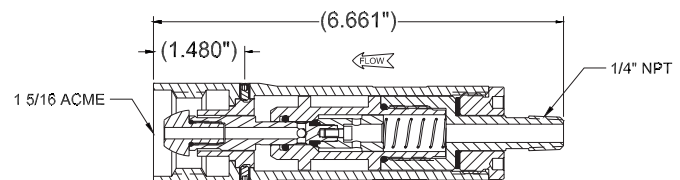

Ordering Information

Part Number	Application	Inlet Connection	Outlet Connection	Materials
7193U-10L	Filling of DOT cylinders with Type 1 Connections	1/4" M. NPT	Type 1 Connection (15/16" F. ACME)	Brass

Hose End Adapter for Lift Truck Cylinder Filling 7193L-10A

Application

The 7193L-10A is designed to provide quick and easy attachment of the filling hose to DOT cylinders equipped with RegO 7141M check connectors.

The 1 1/4" ACME outlet threads facilitate rapid make-up. When connected, back-checks in the adapter and check connector automatically open. Low pressure drop between the two ensures high filling rates. An integral check closes when disconnected, eliminating the need to close any valves manually to disconnect the charging hose.

Because a leak-tight seal is formed before the integral check opens or closes, product loss is kept to an absolute minimum when connecting or disconnecting the loading hose.

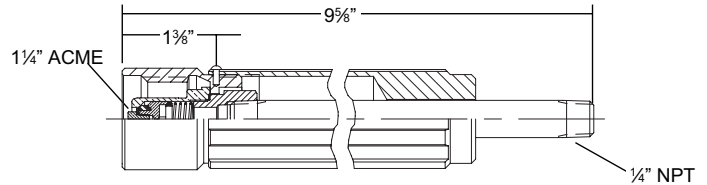

7193L-10A

Ordering Information

Part Number	Application	Inlet Connection	Outlet Connection	Body Material	Accessories
					Adapter
7193L-10A	Filling of Fork Lift Cylinders*	1/4" M. NPT	1 1/4" F. ACME	Brass	5760A

*The 7193L-10A is intended to be permanently attached to the filling hose.

A 5760A adapter enables the 7193L-10A to be attached to the POL connection on the 7193D-10 at regular cylinder filling stations to allow for occasional filling of fork lift cylinders.

Lever Operated Hose End Adapter for Fork Lift Cylinder Filling 7193K-10B

Application

Designed to drastically reduce labor and time when continuously filling large numbers of lift truck cylinders equipped with RegO 7141M check connectors.

Rapid make-up is accomplished by simply slipping the adapter yoke behind the hex wrenching section of the 7141M connector and depressing the lever. When the cylinder is filled, the adapter is easily disengaged by releasing the operating lever. When connected, back checks in the adapter and connector automatically open. An integral check closes when disconnected, eliminating the need to close any valves manually on the filling manifold to disconnect the charging hose. The shut-off valve on the container must be closed after filling.

Because a leak-tight seal is formed before the checks close, product loss is kept to an absolute minimum when connecting or disconnecting the loading hose.

The 7193K-10B is intended to be permanently attached to the filling hose.



7193K-10B

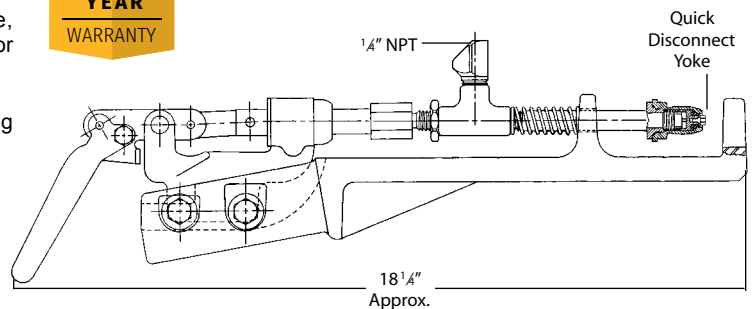

Ordering Information

Part Number	Application	Inlet Connection	Outlet Connection	Materials
7193K-10B	Lever Operated for Quick Filling of Fork Lift Cylinders	1/4" F. NPT	Quick Disconnect Yoke*	Brass and Steel

*For use with RegO 7141M check connector.

Combination Valve for Bulk Storage Containers A2805C

Application

Designed for installation on bulk storage containers, this valve combines a pressure gauge mounting and provision for a fixed tube liquid level gauge.

The shut-off valve prevents the pressure gauge from being subjected to constant pressure, thereby prolonging its life and accuracy. The valve may be closed, and the vent valve opened to vent pressure from the gauge to permit replacement.

For fixed liquid level gauging, the valve can be mounted at the maximum permitted filling level. When equipped with a dip tube threaded $\frac{1}{8}$ " M.NPT, it can be installed at any convenient level.

Materials

Body A2805C.....	Ductile Iron
Bonnet.....	Steel
Valve Stem.....	Stainless Steel
Vent Stem.....	Stainless Steel
Valve Stem Seal.....	Resilient Synthetic Rubber
Vent Seal.....	Resilient Synthetic Rubber
Valve Seat.....	Nylon



A2805C

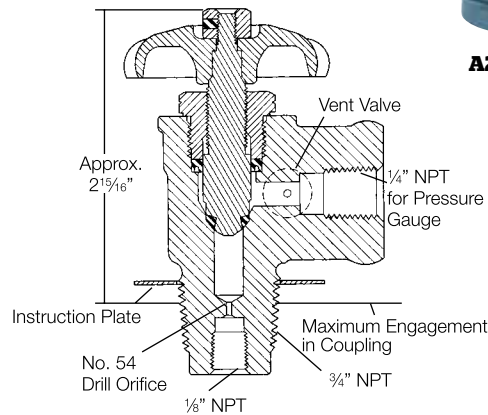

Ordering Information

Part Number	Container Connection	Service Connection	Liquid Level Vent
A2805C	$\frac{3}{4}$ " M. NPT	$\frac{1}{4}$ " F. NPT for Gauge Mounting	Tee Handle

*Has $\frac{1}{8}$ " F. NPT opening for installing separate dip tube.

Gritrol Fuel Line Filters 12802

Application

Designed especially for use in liquid motor fuel lines to trap foreign material which otherwise may damage precision components in the LP-Gas carburetion system. These filters incorporate an integral sintered metal filter element in a straight through design.



12802

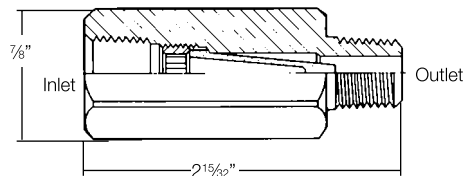

Ordering Information

Part Number	Inlet Connection	Outlet Connection
12802	$\frac{1}{4}$ " F. NPT	$\frac{1}{4}$ " M. NPT

Vent Valves 3165C, 3165D, 3165S and TSS3169

Application

Especially designed to bleed off liquid or vapor pressures trapped in transfer lines. When installed in the downstream boss of RegO globe and angle valves used at the end of a liquid transfer hose, the bleeder valve allows for the controlled venting of the product and indicates to the operator that the valves are closed and he can disconnect the coupling. They may also be used as a fixed liquid level gauge where the dip tube is part of the container.

The 3165C, 3165S and TSS3169 incorporates a No 54 drill size orifice. The 3165D incorporates a No 72 drill size orifice.

An optional instruction plate with "Stop Filling When Liquid Appears" may be ordered for use with these valves.



Materials

Body (3165) Brass
 Body (TSS3169) Stainless Steel
 Seat Disc (3165) Resilient Synthetic Rubber
 Seat Disc (3169) Teflon

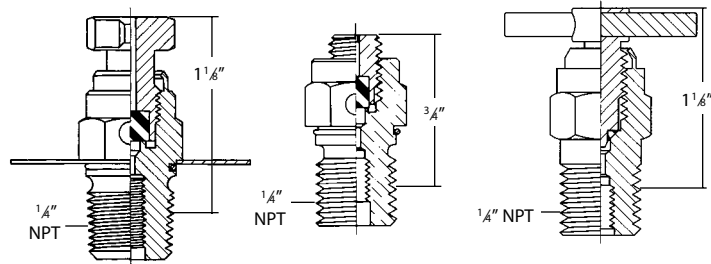

Ordering Information

Part Number	Service	Connection	Actuation	Accessories
				Warning Plate Kit
3165C	LP-Gas Only	1/4" M. NPT	Ribbed	2550-40P
3165D			Slotted	
3165S			Tee Handle	
TSS3169	LP-Gas & NH3			

Fixed Liquid Level Gauges 3165 Series and TA3169F

Application

Especially designed to provide a visible warning when containers are filled to the maximum permitted filling level. At the start of the filling operation, with the vent stem opened, the valve discharges vapor. When the maximum permitted filling level is reached, the valve discharges liquid. The 3165CF*, 3165CF12.0, 3165SF12.0 and TA3169F12.0 incorporate a No 54 drill orifice; the 3165DF* and 3165DF12.0 incorporate a No 72 drill orifice. They all are normally furnished with a 12" 3/16" OD dip tube.

An optional instruction plate with "Stop Filling When Liquid Appears" may be ordered for use with these valves.

Materials

Body (3165) Brass
 Body (TA3169) Stainless Steel
 Seat Disc (3165) Resilient Synthetic Rubber
 Seat Disc (TA3169) Teflon



3165CF12.0
3165DF12.0



TA3169F12.0

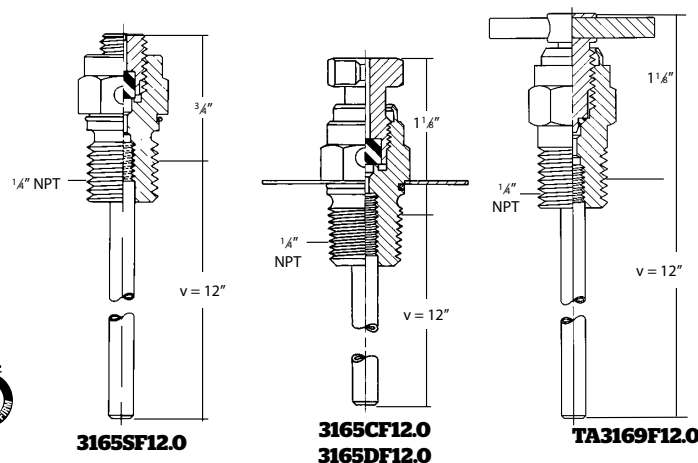

Ordering Information

Part Number	Service	Connection	Actuation	Dip Tube Length	Accessories
					Warning Plate Kit
3165CF*	LP-Gas Only	1/4" M. NPT	Ribbed	*	2550-40P
3165DF*				12"	
3165CF12.0			Slotted		
3165DF12.0			Tee Handle		
TA3169F12.0	LP-Gas & NH3				

Spanner Wrench for ACME Connectors 3195-50

Application

This aluminum spanner wrench is especially designed for use with 2 1/4" and 3 1/4" ACME couplings, adapters and caps.



3195-50

Ordering Information

Part Number	For Use With ACME Connector Size
3195-50	2 1/4" & 3 1/4"

Pressure Gauges

Application

Especially designed in a variety of sizes and construction for the LP-Gas and anhydrous ammonia industry.



612-PG



5575

Ordering Information

Part Number	Service	Case Material	Maximum Pressure	Inlet Connection M.NPT	Case Size	Increment Divisions		
2434A-2*	LP-Gas Only	Steel	35" w.c. and 20 oz. (Dual)	1/4"	2 1/2"	1" w.c. and 1 oz.		
2434-2**			30 PSIG		2"	1/2 PSI		
3226A-3		Brass	60 PSIG			1 PSI		
2411			Steel			100 PSIG	2 PSI	
5575		Brass				300 PSIG	2"	5 PSI
5547			Steel		60 PSIG	2 1/2"		5 lb.
5576		150 PSIG						
1286		400 PSIG						
948		NH ₃ and LP-Gas	Steel		0-300 PSI	1/8"	1 1/2"	30 PSI
948B					Brass		300 PSIG	2"
A8060	60 PSIG							
A8150	Steel		150 PSIG					
A8400			400 PSIG					
612-PG	LP-Gas Only		Steel	0-300 PSI	1/8"		1 1/2"	30 PSI
612-G2							2"	5 PSI

* 1/4" Hose Connection
** 1/8" M. NPT Connection

Needle Valves 1224, 1316 and 1318

Application

These valves are high quality, “true” throttling valves. Unlike most so-called needle valves, both the body seat and stem are tapered to provide fine, precise control over a wide range of adjustment without stem galling.

The 1224 may be used as a small, inexpensive shut-off valve between a pressure gauge and bulk storage container to allow for convenient gauge replacement.

The 1316 and 1318 provide taper pipe thread by left hand hose connection threads and are useful in a wide range of torch and fuel burner applications where an accurate throttling action is required.

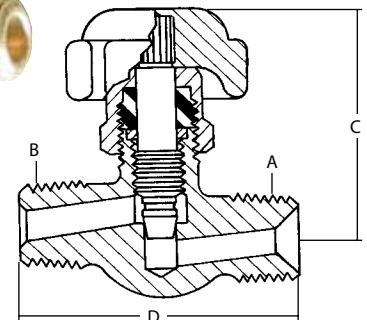

Ordering Information

Part Number	A. Inlet Connection	B. Outlet Connection	C. Height	D. Length
1224WA	1/4" M. NPT	1/4" M. NPT	1 9/16"	1 3/4"
1316WA	9/16" - 18 L.H.	1/8" M. NPT		
1318WA		1/4" M. NPT		

Cross Reference by Part Number

302	A31	1584VN	A33	3188C	H13	6542R12.0	C10	7579P	F21
302V	A31	1586VH	A33	3191	H5	6543A11.1	C10	7579S	F26
302V9	A31	1586VL	A33	3194-90	H9	6543A11.1/6543R11.1	C10	7580F-20	F20
302V9LS	A31	1586VN	A33	3194-90G	H9	6543A11.7	C10	7583G	D13
597FA	A32	1588VH	A33	3194-90GS	H9	6543A11.7/6543R11.7	C10	7590U	F19
597FB	A32	1588VL	A33	3194-91L	H9	6543R11.1	C10	7590U-10	F20
597FC	A32	1588VN	A33	3194-91S	H9	6543R11.7	C10	7590U-20	F19
597FD	A32	1708C	H9	3194-91V	H9	6555R10.6	C9	7591U	F19
612-G2	J22	2070C0	J6	3194C	F27	6555R11.6	C9	7605A-BT	J13
612-PG	J22	2071-L25.7	J6	3195	H5	6555R12.0	C9	7605AP-15	J13
901-400	B18	2071-L39.7	J6	3195-50	J22	6584C	F27	7605AP-16	J13
901C1	B13	2139	F14	3197C	F26	6586D	F30	7606RM	J13
901C3	B14	2139A	F14	3199W	A36	6587EC	F26	7647DC	F25
901C5	B14	2302-31	A37	3199W	F17	6588LE	H12	7647SC	F25
903-400	B18	2411	J22	3199W	H13	6589LE	H12	7704LP	E16
903-500	B18	2434-2	J22	3200C	G15	7034LP	E13	7704P	E16
903-500	C13	2434A	A38	3200L	G15	7034P	E13	7705P	E16
903-500	E25	2434A-2	J22	3226A-3	J22	7053T	E9	7706P	E16
907FP	H9	2503-19	A37	3272E	F11	7141F	H6	7901T	E9
912FA20	H15	2503-22	A37	3272F	F11	7141FP	H9	7901TA	E9
912FS12	H15	2723C	F16	3272G	F11	7141M	H6	7901TB	E9
912FS20	H15	2884D	F17	3272H	F12	7142LF	H7	7901TB	J14
912FS30	H15	2906A	H14	3282A	F11	7142LM	H7	7901TC	E9
912FS36	H15	2906D	H14	3282B	F11	7177	J14	7901TLA	E10
912JA20	H15	2906E	H14	3282C	F11	7188	J14	7901TLB	E10
912JS12	H15	2906F	H14	3292A	F11	7188-21	J14	7901TLC	E10
912JS20	H15	2906G	H14	3292B	F11	7188HS	J14	7993AD-10L	E10
912JS36	H15	2962	A39	3705RC	H8	7188MS	J14	7993AU-10L	E10
912PA20	H15	3119A	H6	5547	J22	7193D	J14	7993BD-10L	E10
912PA36	H15	3120	H6	5575	J22	7193D-10	J17	7993BU-10L	E10
912PA48	H15	3121	H6	5576	J22	7193D-10L	J14	7993CD-10L	E10
912PS12	H15	3125L	D16	5726B34	A30	7193D-10L	J18	7993CU-10L	E10
912PS20	H15	3127G	D15	5727B34	A30	7193K-10B	J19	8117	E24
912PS30	H15	3127G	D16	5754B4	A30	7193L-10A	J19	8118P	E24
912PS36	H15	3127H	D16	5755B4	A30	7193T-10	J17	8532AG	D18
912PS48	H15	3127J	D16	5760A	H14	7193U-10	J17	8533AG	D18
913JS05	H15	3127K	D15	5760B	H14	7193U-10L	J18	8542AG	D17
913JS05A	H15	3127K	D16	5760C	H14	7194-1	J14	8542G	D17
913JS12	H15	3127L	D16	5760D	H14	7194H-3	J14	8543G	D11
913JS20	H15	3127P	D16	5760S	H14	7194HD	J14	8543T	D11
913KL12	H15	3127U	D16	5761A	H14	7194M-3A	J14	8544A375T	D11
913LS12	H15	3129G	D15	5761B	H14	7194MD	J14	8544G	D11
913PS05	H15	3129G	D16	5761C	H14	7501L	F22	8544K	D11
913PS05A	H15	3129H	D16	5761D	H14	7502L	F22	8544T	D11
913PS12	H15	3129J	D16	5763D	H10	7505AP	E13	8545-500	D21
913PS12G	H15	3129K	D15	5764A	H10	7506AP	E13	8545AK	D12
913PS12H	H15	3129K	D16	5764B	H10	7507AP	E13	8546G	D11
913PS12S	H15	3129L	D16	5764C	H10	7508AP	E13	8546T	D11
913PS20	H15	3129P	D16	5764D	H10	7509BP	E13	8555D10.6	C9
913PS30	H15	3129U	D16	5764E	H10	7510BP	E13	8555D11.6	C9
913PS36	H15	3131G	D14	5764W	H10	7511AP	E13	8555DL11.6	C8
913PS48	H15	3132G	D14	5765D	H10	7511FP	E13	8555DL11.6	C8
948	J22	3133G	D14	5765E	H10	7511FP	E13	8555R10.6	C9
948B	J22	3135G	D14	5765F	H10	7512AP	E13	8555R11.6	C9
970	A36	3135MG	D18	5765M	H10	7513AP	E13	8556	B17
970	H13	3139-18	A35	5765PR	H9	7513FP	E13	8593AL16.0	C7
970AW	A36	3139-26	A35	5766E	H10	7513FP	E13	8593AL16.0	C7
970AW	H13	3139-38	A35	5766F	H10	7514AP	E13	8684G	D13
970AWXS	H13	3144-9P	H9	5767F	H10	7514FP	E13	8685G	D13
970AX	A36	3144-91	H9	5767G	H10	7514FP	E13	9101C1	B13
970AX	H13	3146	F30	5767H	H10	7517AP	E13	9101D11.1	B13
970AXS	A36	3146S	F30	5767M	H10	7517FP	E13	9101D11.7	B13
970AXS	H13	3165C	J21	5768G	H10	7517FP	E13	9101H3	B14
970HT	A36	3165CF	J21	5769H	H11	7518AP	E13	9101H5	B14
970HT	H13	3165CF12.0	J21	5769HVB	H11	7518FP	E13	9101H6	B14
970JR	H13	3165D	J21	5769K	H10	7518FP	E13	9101P5	B15
970S	A36	3165DF	J21	5769K	H11	7525B4	A28	9101P5H	B15
970S	H13	3165DF12.0	J21	5769M	H10	7525B4	A28	9101P6	B15
970WXS	A36	3165S	J21	5769M	H11	7525B34	A28	9101P6H	B15
1212 KIT	A38	3165SF12.0	J21	5769VSS	H11	7525B34	A28	9101R1	B13
1224WA	J23	3170	F28	5776	H9	7534B	D13	9101R11.1	B13
1286	J22	3171	H5	5778	H9	7534G	D13	9101R11.7	B13
1300	H14	3171A	H5	5807	A30	7550P	E17	9101Y5H	B14
1316WA	J23	3174-9P	H9	5808	A30	7550PX	E17	9102D11.1	B13
1318WA	J23	3174-91	H9	5820	A30	7551P	E17	9102R11.7	B13
1328	H14	3174-93	H9	5828	A30	7554LAV	E8	9103D10.6	B9
1331	H14	3174C	F27	5832	A30	7554LV	E8	9103D11.6	B9
1332	H14	3175	H5	6016-60D	J13	7554SAV	E8	9103T9F	B10
1350E	A37	3175A	H5	6016PN-50	J13	7554SV	E8	9104PPA	B16
1350R	A37	3175B	H5	6016PN-80	J13	7556R12.0	C11	9104PT10.1	B16
1450E	A37	3175P	H9	6532A12.0	C10	7560-55	D19	9104PT10.7	B16
1450R	A37	3176	F30	6532A12.0/6532R12.0	C10	7560-56	D19	9106CO	B11
1494-1	H14	3179B	H8	6532R12.0	C10	7572-400	F31	9107K8A	B12
1519A2	F10	3180C	F28	6533A10.5	C10	7572C-14A	F20	10538P	H8
1519A3	F10	3181	H5	6533A10.5/6533R10.5	C10	7572C-15A	F20	12472	F11
1519A4	F10	3181A	H5	6533A11.7	C10	7573D	F28	12802	J20
1519B4	F10	3183AC	F28	6533A11.7/6533R11.7	C10	7573DC	F28	12982	H13
1519C2	F9	3184-90	H9	6533R10.5	C10	7574	F11	15774-1	H14
1519C4	F9	3185	H5	6533R11.7	C10	7574L	F11	A1519A2	F10
1584VH	A33	3188A	H13	6542A12.0	C10	7576	H8	A1519A4	F10
1584VL	A33	3188B	H13	6542A12.0/6542R12.0	C10	7577V	H8	A1519A6	F10

Cross Reference by Part Number

A1519B4.....	F10	A3219FA600W.....	G13	A8016-9P.....	H9	HA7514AP.....	E14	LV5503Y8.....	A24
A2137.....	F14	A3219RT.....	G15	A8016-93.....	H9	HA7517AP.....	E14	M3131G.....	C6
A2137A.....	F14	A3227G.....	F11	A8016DBC.....	E20	HA7518AP.....	E14	MV3132G.....	C6
A2141A6.....	J7	A3276BC.....	F30	A8016DP.....	E21	L6579.....	F21	MV3132G.....	D14
A2141A6L.....	J7	A3282C.....	F11	A8017DH.....	E22	L6579.....	F21	N970P.....	H8
A2141A8.....	J7	A3292A.....	F11	A8017DLP.....	E22	L6579C.....	F21	PG8475RL.....	C6
A2141A8L.....	J7	A3292B.....	F11	A8017DP.....	E22	L7579.....	F21	PG8475RL.....	C6
A2141A10.....	J7	A3292C.....	F11	A8018DP.....	E23	L7579C.....	F21	PT6542A12.0.....	C10
A2141A16.....	J7	A3400L4.....	F31	A8020D.....	E22	LV404B4.....	A26	PT6542A12.0/6542R12.0C10	
A2697-20R.....	F21	A3400L6.....	F31	A8060.....	J22	LV404B4V9.....	A26	PT6542R12.0.....	C10
A2697-20R.....	F27	A3500L4.....	F15	A8150.....	J22	LV404B9.....	A26	PT6543A11.1.....	C10
A2797-20R.....	F21	A3500N4.....	F15	A8400.....	J22	LV404B9V9.....	A26	PT6543A11.1/6543R11.1C10	
A2797-20R.....	F27	A3500P4.....	F15	A8434G.....	D10	LV404B34.....	A27	PT6543A11.7.....	C10
A2805C.....	J20	A3500R6.....	F15	A8434N.....	D10	LV404B34V9.....	A27	PT6543A11.7/6543R11.7C10	
A3146.....	F30	A3500T6.....	F15	A8436G.....	D10	LV404B39.....	A27	PT6543R11.1.....	C10
A3149G.....	D14	A3500V6.....	F15	A8436N.....	D10	LV404B39V9.....	A27	PT6543R11.7.....	C10
A3149L055.....	D14	A4500Y8.....	F15	A8523.....	F13	LV404B46.....	A26	PT7556R12.0.....	C11
A3149L200.....	D14	A5764D.....	H10	A8525.....	F13	LV404B46V9.....	A26	PT9102R1.....	B13
A3149MG.....	D14	A5764E.....	H10	A8563AG.....	D20	LV404B96.....	A26	PT9102R11.1.....	B13
A3175.....	H5	A5764W.....	H10	A8563G.....	D20	LV404B96V9.....	A26	PT9102R11.7.....	B13
A3175A.....	H5	A5765C.....	H10	A8564AG.....	D20	LV404Y9.....	A29	SF7647V11.0.....	F23
A3175P.....	H9	A5765D.....	H10	A8564G.....	D20	LV404Y39.....	A29	SF7647V11.1.....	F23
A3176.....	F30	A5765E.....	H10	A8573AG.....	D20	LV960-48.....	A38	SFL7579V10.6.....	F24
A3184-8R.....	F21	A5765F.....	H10	A8573G.....	D20	LV960-72.....	A38	SFL7579V11.0.....	F24
A3184-90.....	H9	A5767F.....	H10	A8574AG.....	D20	LV960-120.....	A38	SFL7579V12.3.....	F24
A3185.....	H5	A5768H.....	H10	A8574G.....	D20	LV3403B4.....	A20	SFL7579V13.0.....	F24
A3186.....	F30	A5769H.....	H10	A9091-18L.....	J4	LV3403B4V0.....	A20	SFL7579V13.8.....	F24
A3187S.....	F30	A5769K.....	H10	A9091-18LX.....	J4	LV3403B4V3.....	A20	SS8001G.....	D16
A3194-8R.....	F21	A5776.....	H9	A9091-18N.....	J4	LV3403B4V9.....	A20	SS8001J.....	D16
A3194-90.....	H9	A6010.....	J11	A9091-M24.0.....	J4	LV3403B44R.....	A19	SS8001L.....	D16
A3194-91L.....	H9	A6016.....	J10	A9091-M36.0.....	J4	LV3403B46R.....	A19	SS8001U.....	D16
A3194-91S.....	H9	A6024.....	J10	A9091-M48.0.....	J4	LV3403TR.....	A14	SS8002G.....	D16
A3194-91V.....	H9	A6586D.....	F30	A9091-M60.0.....	J4	LV3403TRV9.....	A14	SS8002J.....	D16
A3195.....	H5	A7505AP.....	E12	A9091-M72.0.....	J4	LV4403-400.....	A39	SS8002L.....	D16
A3196.....	F30	A7506AP.....	E12	A9091R.....	J5	LV4403B1D.....	A17	SS8002U.....	D16
A3198S.....	F30	A7507AP.....	E12	A9092R.....	J5	LV4403B3D.....	A17	SS8021G.....	D16
A3209D050.....	G8	A7508AP.....	E12	A9093RS.....	J5	LV4403B3RD.....	A17	SS8021J.....	D16
A3209D080.....	G8	A7509BP.....	E12	A9093TS.....	J5	LV4403B4.....	A17	SS8021L.....	D16
A3209DE050.....	G9	A7510BP.....	E12	A9094RS.....	J5	LV4403B4D.....	A16	SS8021U.....	D16
A3209DE080.....	G9	A7511AP.....	E12	A9094TS.....	J5	LV4403B5D.....	A17	SS8022G.....	D16
A3209DT050.....	G8	A7511FP.....	E12	A9095RS.....	J5	LV4403B16D.....	A17	SS8022J.....	D16
A3209DT080.....	G8	A7512AP.....	E12	A9095TS.....	J5	LV4403B16RABD.....	A17	SS8022L.....	D16
A3209DTE050.....	G9	A7513AP.....	E12	AA1584VH.....	A33	LV4403B16RAD.....	A17	SS8022P.....	D16
A3209DTE080.....	G9	A7513FP.....	E12	AA1584VL.....	A33	LV4403B16RD.....	A17	SS8022U.....	D16
A3211D080.....	G10	A7514AP.....	E12	AA1584VW.....	A33	LV4403B36D.....	A17	T3132G.....	D14
A3211D110.....	G10	A7514FP.....	E12	AA1586VH.....	A33	LV4403B36RABD.....	A17	TA3169F12.0.....	J21
A3212R 105.....	G17	A7517AP.....	E12	AA1586VL.....	A33	LV4403B36RAD.....	A17	TA7034LP.....	E12
A3212R 175.....	G17	A7517FP.....	E12	AA1586VW.....	A33	LV4403B46.....	A16	TA7034P.....	E12
A3212R 250.....	G17	A7518AP.....	E12	AA3126L030.....	D14	LV4403B46D.....	A17	TA7505AP.....	E12
A3212R T105.....	G17	A7518FP.....	E12	AA3126L250.....	D14	LV4403B46R.....	A16	TA7506AP.....	E12
A3212R T175.....	G17	A7537L4.....	F13	AA3126L312.....	D14	LV4403B46RD.....	A17	TA7507AP.....	E12
A3212R T250.....	G17	A7537L4F.....	F13	AA3130UA250.....	D14	LV4403B56D.....	A17	TA7509BP.....	E12
A3213D150.....	G16	A7537N4.....	F13	AA3130UA265.....	D14	LV4403B56RABD.....	A17	TA7510BP.....	E12
A3213D200.....	G16	A7537N4F.....	F13	AA3135MA250.....	D18	LV4403B56RAD.....	A17	TA7511AP.....	E12
A3213D300.....	G16	A7537P4.....	F13	AA3135MA265.....	D18	LV4403B56RD.....	A17	TA7511FP.....	E12
A3213D400.....	G16	A7537P4F.....	F13	AA3135MUA250.....	D17	LV4403B66.....	A16	TA7512AP.....	E12
A3213DT150.....	G16	A7539R6.....	F13	AA3135MUA265.....	D17	LV4403B66D.....	A17	TA7513AP.....	E12
A3213DT200.....	G16	A7539R6F.....	F13	AA3135UA250.....	D14	LV4403B66R.....	A16	TA7513FP.....	E12
A3213DT300.....	G16	A7539T6.....	F13	AA3135UA265.....	D14	LV4403B66RA.....	A21	TA7514FP.....	E12
A3213DT400.....	G16	A7539T6F.....	F13	AA8532MA250.....	D18	LV4403B66RAB.....	A21	TA7517AP.....	E12
A3217AL160.....	G11	A7539V6.....	F13	AA8532MA265.....	D18	LV4403B66RABD.....	A17	TA7517FP.....	E12
A3217AL210.....	G11	A7539V6F.....	F13	AA8533MA250.....	D18	LV4403B66RAD.....	A17	TA7894P.....	E18
A3217AL260.....	G11	A7550P.....	E17	AA8533MA265.....	D18	LV4403B66RD.....	A17	TSS3169.....	J21
A3217AL410.....	G11	A7550PX.....	E17	AA8542UA250.....	D17	LV4403H222.....	A18	VA6010.....	J11
A3217AL510.....	G11	A7551P.....	E17	AA8542UA265.....	D17	LV4403H414.....	A18	VA6016.....	J10
A3217ALPA.....	G11	A7571LA.....	H4	C5763N.....	H9	LV4403H420.....	A18	VA6024.....	J10
A3217ALPA.....	G11	A7571LB.....	H4	C5765N.....	H9	LV4403H4614.....	A18	VA8436G.....	D10
A3217AR160.....	G11	A7575L2.....	H4	C5767N.....	H9	LV4403H4620.....	A18	VA8436N.....	D10
A3217AR210.....	G11	A7575L3.....	H4	C5769N.....	H9	LV4403H6614.....	A18	VFA6010.....	J12
A3217AR260.....	G11	A7575L4.....	H4	D912J12.....	A36	LV4403SR4.....	A15	VFA6016.....	J12
A3217AR410.....	G11	A7575L5.....	H4	D912J20.....	A36	LV4403SR9.....	A15	VFA6024.....	J12
A3217AR510.....	G11	A7616.....	J15	D912J30.....	A36	LV4403SR96.....	A15	W3132G.....	D14
A3217ARPA.....	G11	A7624.....	J15	D912P12.....	A36	LV4403TR4.....	A15	X1584VL.....	A35
A3217ARPA.....	G11	A7704LP.....	E16	D912P20.....	A36	LV4403TR9.....	A15	X1584VN.....	A35
A3217DAL160.....	G11	A7704P.....	E16	D912P30.....	A36	LV4403TR96.....	A15	X1586VL.....	A35
A3217DAL210.....	G11	A7705P.....	E16	D913J12.....	A36	LV4403Y4.....	A24	X1586VN.....	A35
A3217DAL260.....	G11	A7706P.....	E16	D913J20.....	A36	LV4403Y46R.....	A24	X1588VL.....	A35
A3217DAL410.....	G11	A7707L.....	E6	D913J20.....	A36	LV5503B4.....	A22	X1588VN.....	A35
A3217DAL510.....	G11	A7708L.....	E6	D913P12.....	A36	LV5503B6.....	A22		
A3217DAR160.....	G11	A7793A.....	E5	D913P20.....	A36	LV5503B8.....	A22		
A3217DAR210.....	G11	A7794.....	J16	D913P30.....	A36	LV5503G4.....	A25		
A3217DAR260.....	G11	A7796.....	J16	DG8475RL.....	C6	LV5503H414.....	A23		
A3217DAR410.....	G11	A7797A.....	E5	DP8475RL.....	C6	LV5503H614.....	A23		
A3217DAR510.....	G11	A7853A.....	G20	FA6010.....	J12	LV5503H620.....	A23		
A3217LA.....	G11	A7883FK.....	G18	FA6016.....	J12	LV5503H620V.....	A23		
A3217LA.....	G11	A7914A.....	E7	FA6024.....	J12	LV5503H640.....	A23		
A3217RA.....	G11	A8012C.....	E19	G8475RL.....	C6	LV5503H640V.....	A23		
A3217RA.....	G11	A8012D.....	E19	G8475RL.....	C6	LV5503H814.....	A23		
A3219FA400L.....	G13	A8013D.....	F16	G8475RLW.....	C6	LV5503H820.....	A23		
A3219FA400W.....	G13	A8013DA.....	F16	G8475RLW.....	C6	LV5503H840.....	A23		
A3219FA600L.....	G13	A8013DB.....	F16	HA7513AP.....	E14	LV5503Y6.....	A24		



LP-Gas & Anhydrous Ammonia Equipment

2018



Phone: 336-449-7707
Fax: 336-449-6594

100 Rego Drive, Elon, NC 27244 USA

regoproducts.com

ecii@regoproducts.com

CATALOG L-500

PRINTED IN THE USA 10-1017-0788